



Assembly Instructions

Version 2024_1
Exaco Edits: 8-30-24



*Assembly Videos can
be found by scanning
the code to the left
with your
smartphone.*

Or find the link to our YouTube page at www.exaco.com. Go to the Victorian Greenhouse Playlist for all videos.

www.exaco.com
877-760-8500

Table of Contents

Introduction & General Information.....	4-13
Basic Assembly Order of Greenhouse.....	4
Required Tools.....	5
Safety Considerations.....	5
Helpful Suggestions.....	5
Greenhouse Version Layouts and Diagrams.....	6-7
Doors and Door Optional Upgrades.....	8
Windows and Window Options.....	8
Optional Accessories and Upgrades.....	9
Placement of Greenhouse.....	10
Foundation and Anchoring.....	10-11
Greenhouse Floor.....	11
Water and Electricity.....	11
Ventilation and Cooling.....	11-12
Heating the Greenhouse.....	12
Using the Greenhouse as Additional Living Space.....	12
Maintenance.....	13
Foundation Measurements and Planning.....	14-17
UPGRADE OPTION: Planning/Building a Stem Wall.....	14-15
UPGRADE OPTION: Hinged Door/s on a Stem Wall with Drop Door Kit.....	16
UPGRADE OPTION: Sliding Door/s on a Stem Wall with Drop Door Kit.....	17
Glazing Specs.....	18-20
Diagram of Greenhouse Extrusions/Profiles.....	21
Assembling your Greenhouse Frame	
Foundation Frame and Side Walls.....	22-30
Building the Roof.....	31-38
Gutter Downspouts and Roof Decorations.....	39
Crossbar for Roof Windows.....	40

Installing the Glazing.....	41-45
Glazing Installation for Modern 34/36.....	41-42
Gasket Installation.....	43-45
Accessory Page w/ QR Code.....	46
Door Assembly and Installation.....	47-70
Standard Kit Hinged Door Assembly and Information.....	47-59
UPGRADE OPTION: Sliding Door Low Threshold Installation.....	60-64
UPGRADE OPTION: Sliding Door Installation.....	65-70
Window and Vents.....	71-83
Roof Window/Vent Assembly/Installation.....	71
Roof Vent Openers.....	72-74
UPGRADE OPTION: Roof Vent Fly Screen.....	75
Louvered Window Assembly/Installation	76-78
Louvered Window Cover.....	79
UPGRADE OPTION: Louver Vent Fly Screen.....	80
UPGRADE OPTION: Push Out Window Assembly.....	81-83
Shelving Options	
OPTIONAL ACCESSORY: Narrow Top Shelf Assembly.....	84
OPTIONAL ACCESSORY: Seed Bed/Tray Assembly.....	85
OPTIONAL ACCESSORY: 2 Slat Shelf Assembly.....	86
OPTIONAL ACCESSORY: 5 Slat Shelf Assembly.....	87
UPGRADE OPTION: Exhaust Fan Installation.....	88
Customer Service Information.....	89

Thank you for purchasing a Janssens' Modern Greenhouse, imported and distributed in North America by Exaco in Austin, TX. Exaco will provide all the North American based customer support for you greenhouse. Please feel free to reach to Exaco customer service with any questions you may have during assembly!

Questions? Need Assembly Support?

Please call Exaco at 877-760-8500 or email customerservice@exaco.com.

Introduction

In this manual, you will find the assembly instructions for all basic/standard-model greenhouses. However, this manual also contains pages which apply to optional accessories that may not be included with your kit. Greenhouse "kits" vary by retailer. Some retailers may bundle additional accessories with their greenhouses - please check your order closely so you understand which accessories your greenhouse includes before building. It is also very helpful to plan out where each of these additional accessories will go to determine if you need to insert bolts/hardware during the build.

This greenhouse is designed for cultivation of plants/flowers. Therefore leakage, water drops and condensation inside the building are allowed. The building may only be entered by competent persons during cultivation or maintenance. Painted aluminum profiles/extrusions are powder-coated for a durable finish. The rubber strips have been treated with oil/silicone on the interior to facilitate the assembly. The building should be mounted on a solid concrete foundation deep enough to get a solid and frost-free ground. Anchoring of the foundation is vital and should be checked periodically. During winter, the roof will need to be cleared of snow or supported in a suitable way (see additional notes in "Maintenance" section). The greenhouse should be built in a location protected from strong winds. Protective gear (such as gloves) should be used during assembly in order to avoid injuries. One should at all times pay attention to the local building regulations.

The Modern greenhouse has been engineered and manufactured in Belgium using the metric system. We strongly recommend having a metric or combination tape measure on hand during assembly. We have converted and added inches to the manual when feasible – however for the most accurate and precise measurements some do still remain in metric. Conversion of metric to inches results in unusual fractional increments or decimals that become difficult to measure on a standard US customary ruler/tape measure. Using the metric system keeps your measurements more precise. If you prefer to work only in inches, you may use a converter tool available in app stores for smart phones.

Basic Assembly Order of Greenhouse

- Preparing your site – must be level and accommodate anchoring of the structure (see section on "Foundation and Anchoring")
- Sorting of the profiles/extrusions according to the model/size of greenhouse. The aluminum profiles (extrusions) are identified by their cross-section and length. It is helpful to have a metric or combination tape measure for this.
- Assembly of the complete aluminum framework

- Leveling of the construction using a level
- Anchoring/securing of the greenhouse to the ground
- Glazing installation

Required/Recommend Tools

- Metric or Combination Measuring Tape (highly recommended)
- Socket wrench or spanner - 10mm (it is helpful to have multiple)
- Needlenose or other pliers (helpful when installing corner posts)
- Level
- Screwdrivers (Phillips and Flathead)
- Drill + bits
- Impact driver and 1/2" drill bit (useful to notch channel to insert missed bolts)
- Scissors (to cut the rubber)
- Stable Ladder at least 6' tall

Safety Considerations

- Glass safety
 - Store the pallets of glass on firm level surfaces ONLY.
 - Keep your glass pallet dry! Moisture can cause the panes of glass to stick together and may be difficult to separate.
 - Important! Please follow glazing removal instructions on the pallet for steps to safely remove glass panes from the pallet. Contact Exaco if you have not seen these steps!
 - Tempered glass is surprisingly strong. The corners are the most vulnerable – please be aware of the corners when handling and installing glass.
 - Use a quality glass suction cup when handling glass, gloves are recommended.
- Watch your step! Be sure ladders are securely placed before climbing them.

Helpful Suggestions

- Understand which greenhouse accessories you have and where they will be placed. There will be prompts throughout the manual to insert bolts during assembly for doors, window, shelves, shade cloth, misting system, etc.
- If you forget to add a bolt where one is needed, you may create an insertion point in the channel with a 1/2" drill bit and an impact driver. If possible, do it in a place that will be covered by the piece you will be attaching. We do also have hammerhead/T bolts available for purchase that may be added later.
- Look through the entire manual and watch the assembly videos to help you prepare and understand the greenhouse assembly process.
- You may start with assembly of the doors and roof windows. This helps create familiarity with the materials and construction process and gives a head start when it comes to assembly time.
- **The stainless-steel hardware included with your greenhouse is preferred for damp greenhouse settings. This high-quality metal is malleable however, and the heads of the screws can be stripped or break if proper precautions are not taken. Set your driver**

(impact driver is preferred) to a low setting and hand tighten the screw at the end to avoid snapping the screw head.

Please thoroughly read the email that was sent to you from Exaco customer service for additional addendums to the manual and other important information.



Refer to the Exaco YouTube Playlist for helpful animated assembly videos as well as specific installation videos regarding your greenhouse. This playlist is also accessible via the QR code to the left.

Questions? Need Assembly Support?

Please call Exaco at 877-760-8500 or email customerservice@exaco.com.



Modern Greenhouses come standard with the following: (additional accessories/kits may be added)

M23 (7'9" x 10'2") - Foundation frame/base, double hinged doors, two roof vents (1 automatic opener, 1 spindle opener), one louvered window (with optional auto opener and winter cover), two "push-out" side windows, gutters and downspouts.

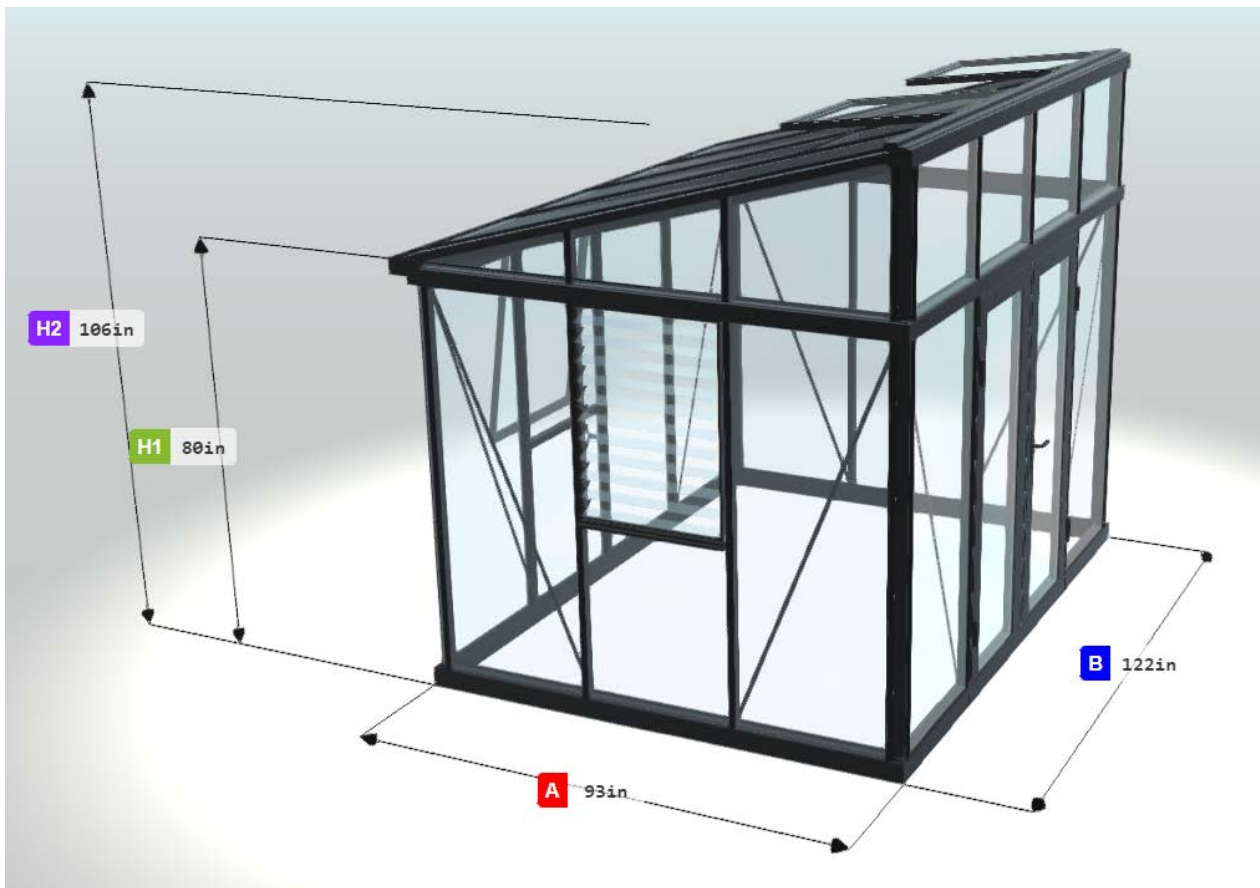

M34 (10'2" x 15') - Foundation frame/base, double hinged doors, two roof vents (1 automatic opener, 1 spindle opener), two louvered window (with optional auto opener and winter cover), two "push-out" side windows, gutters and downspouts.

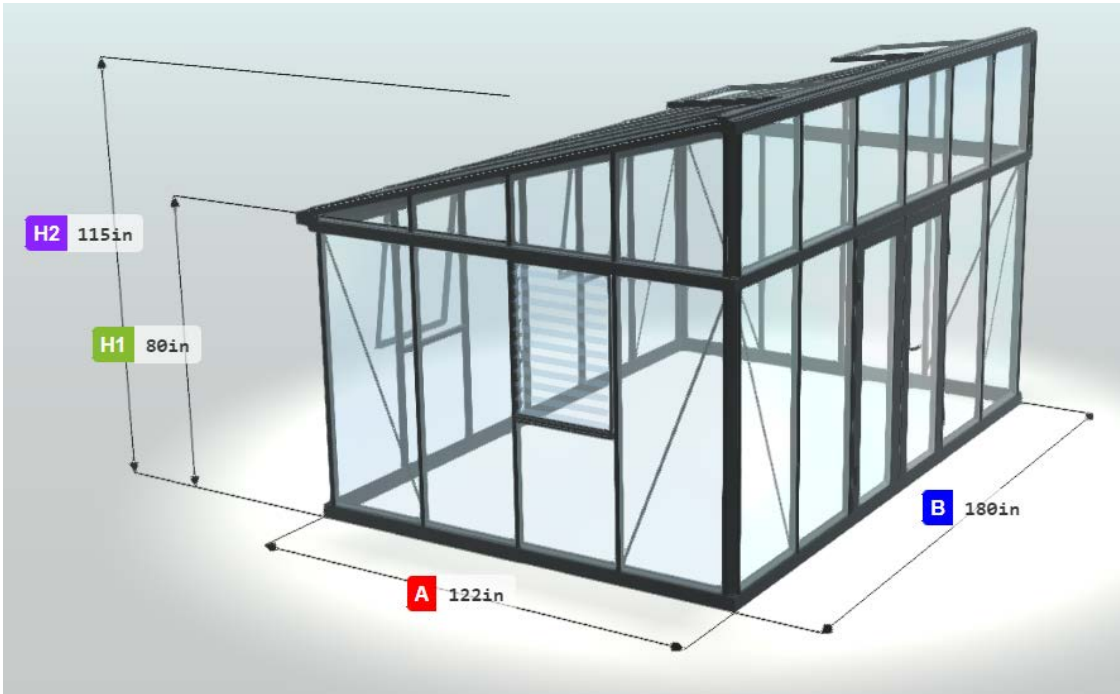

VI 36 (10'2" x 19'10") - Foundation frame/base, double hinged doors, two roof vents (1 automatic opener, 1 spindle opener), two louvered window (with optional auto opener and winter cover), two "push-out" side windows, gutters and downspouts.

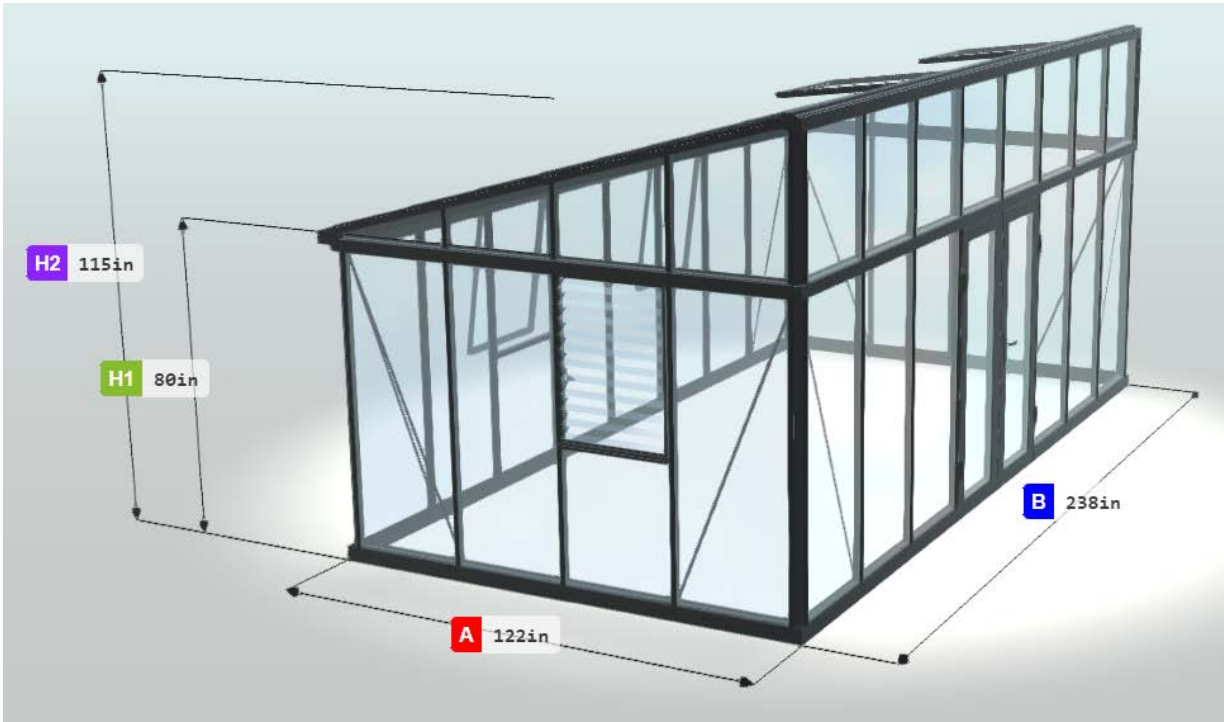

Doors

Our stocked models of Modern Greenhouses will come with a set of double hinged doors. The hinged-doors may be placed on the long or short side of the greenhouse in any bay. Exceptions apply for corner placement, please call Exaco to discuss if you are considering this placement. Upgrades to additional single or double sliding/hinged doors are available.

- The M23 model has 3 wall panes on the side and 4 on the front/back side. We recommend placing the double hinged doors on the 4-panel side. If you wish to place them on the shorter side, please call Exaco to discuss.
- The M34 model has 4 wall panes on the gable end and 6 on the longer side. The hinged doors may be placed on either side.
- The M36 standard greenhouse includes a double hinged door. This model has 4 wall panes on the gable end and 8 on the longer side. A double door opening may be centered on either side.

Windows

Each greenhouse will have a combination of roof vents, louver, and side wall "push-out" windows. The roof vents allow hot air up at the ridge to escape, while the side wall windows act as an intake for cooler air. We recommend the manual spindle opener be used for windows facing strong gusts of wind. The windows cannot be placed side by side. There are a variety of openers available for roof vent windows.

● Roof Vent Openers

- Manual Stick openers - these will be packaged in every roof window kit. They are entry level openers that work on a peg/notch system. Not recommended for daily use but may be used to "lock down" the window if needed (auto openers must be disengaged or your piston will burst).
- Manual Spindle openers - a high-quality stainless steel threaded rod to securely crank the window to desired open position with use of a removable long handle. These are heavy-duty and will hold up well to strong winds if needed.
- Automatic Opener (Ventomax) - this opener utilizes a piston that is filled with oil that expands between 68 to 70 degrees. The oil pushes out the rod of the piston to open the window. When the piston is engaged, there is no manual control of the window. If there is rain when the temperature is above 68 in the greenhouse, it is likely that the roof vent will be open and rain will come in. During the cold months the pistons may be disengaged if heating the greenhouse.

● Louver/Jalousie Side Wall Window

- Placed in a sidewall bay, often opposite the door for a cross breeze
- Comes with a manual opener installed or included auto opener (Sesam Liberty) may be installed
- If you are installing an exhaust fan, the louvered window with auto opener may act as your intake vent.

- **Push Out/Top Hang Side Wall Window** - optional upgrade. It hangs from a hinge at the top and the bottom pushes out. An auto opener may be used.

Note: The louvre and side wall windows may interfere with optional shelving mounted to the walls. Please call Exaco with any questions

Optional Accessories

There are a variety of optional accessories available, some of which are listed below. Some retailers may bundle a shadecloth/shelves with their greenhouse kits.

- Shelves
 - Seed tray/Seedbed - in Modern greenhouses, the seed tray installs along the longest side of the greenhouse at your preferred height. The seed tray is 20" wide and has a 4" planting depth with a white polycarbonate bottom to allow for drainage. It is best to order at the same time as the greenhouse as it has to ship via freight truck due to the length.
 - Top Shelf - is 4" wide and it installs along the longest side of the greenhouse, either above the seed tray or on its own at your preferred height. It is best to order at the same time as the greenhouse as it has to ship via freight truck due to the length.
 - Slat shelves - extremely flexible in terms of height, usage, and all around placement. They are 59" long (across two sections of glass) and may be run end to end for a long stretch of shelving. They may also be centered across 3 panes of glass if desired. Slat design works well for holding pots/planters or it may be used for a work surface. These shelves may be shipped via FedEx or UPS.
 - 2 Slat Shelves - 9" wide x 59" long
 - 5 Slat Shelves - 21" wide x 59" long
- Fly Screens are a brand new addition from Janssens
 - Roof Window Fly Screen - easily installs into roof vent opening
 - Louver Window Fly Screen - clips onto outside of louvered window
 - Door Fly Screen - Slides along the INSIDE of the greenhouse so as not to interfere with the existing doors. May be used with sliding or hinged door (not compatible with hinged door auto closers). Not compatible with greenhouses placed on a wall.
- Ventilation - An exhaust fan may be installed in the gable of the greenhouse to blow out the hottest air. Replace a glass pane with a lexan panel into which you can mount the fan (polycarbonate greenhouse panels may be cut to accommodate the fan). Many exhaust fans will use an external thermostat to control at what temperature it turns on and off. Place an exhaust fan opposite your louver window to create a cross breeze. For the most effective cross breeze, it is often recommended to close window vents to force airflow through your louver window.
- Heaters - see below "Heating the Greenhouse"

Scan the QR code below to take you to our website with photos and more information on accessories for the Modern.



Placement of the Greenhouse

The placement of the greenhouse varies by intended usage, climate, location, and space available. There is a wealth of information to be found online on this subject, here are some considerations:

- Will your greenhouse be in full sun or get afternoon shade? Glass greenhouses do what they are intended to do - heat up quickly on sunny days. Great for the winter, but depending on your climate, it can be a challenge during summer months. Think about what you will be growing as well as the seasonal usage of your new greenhouse to determine appropriate sun exposure. It may help to watch the seasonal variations of sun angles in your yard to determine the placement.
- Depending on what you are growing and where you are located, you may wish to orient your greenhouse east/west or north/south - many garden bloggers have weighed in on this and research may help you consider the options. In many areas of the US, we do get plenty of hours of sunlight. Some users end up placing the greenhouse based on layout/space available, aesthetics and convenience.
- The site must be level. If it is not, you will need to prepare the area to provide a firm and level surface to construct your greenhouse. This may include building a retaining wall or placing your greenhouse on a stem wall - or just leveling out the site. Consider rainwater flow in your yard if you are in a hilly area.

Foundation and Anchoring

All greenhouses must be securely anchored. All greenhouses include corner brackets attached to the foundation/base frame that extend an additional 12" below ground level. The 19'11" long models include an additional pair to use at the midpoint of the long wall. If you are in a very high wind area or are trying to meet the structural specifications for a permit - you may wish to purchase additional corner anchor posts (PRO210) for use at the vertical members.

The manufacturer recommends an 8" wide concrete strip foundation that extends down to the frostline in your area. Please consult your local building codes for this information. It is recommended to leave a 4"-6" diameter hole at the corner for the anchors to be embedded in concrete after the greenhouse frame is assembled and it is confirmed to be level and square.

Alternatively, you may also choose to anchor the greenhouse by trimming the corner anchors off at ground level, cutting them in sections to be used as L brackets to secure the greenhouse frame to your anchoring surface with the appropriate hardware.

Some users have chosen a variety of alternative anchoring methods based on their climate, location, soil composition, and site considerations. These include full concrete slabs, concrete footers, pier and beam constructions, and even timbers. If you are considering the use of wood in your construction, be aware that your greenhouse will likely outlast your wood. If you use pressure treated wood, it is recommended to use a barrier material between the wood and the aluminum frame. When planning your anchoring method, you should keep in mind frost line/ground heaving, wind load, greenhouse location, ground composition, weather, climate, and local building code. If you are unsure, you should consult with a local and experienced builder. Warranty coverage does not extend to damage resulting from improper anchoring of the greenhouse outside of manufacturer's recommendations (see above).

If a permit is needed in your area, we do have structural certification letters and permit sets for many of our greenhouses. They are Texas stamped. We may be able to obtain other state stamped

documents, however if you need them specific to your state, we do not cover this expense. Please contact Exaco if structural documents are needed.

Flooring

The greenhouse does not include flooring material, allowing it to be customized to your needs and use. When planning your flooring, consider the intended use of the greenhouse, the plants that will be grown, drainage, heat sink benefits of the material, insulation, weed blocking, as well as aesthetics. If you use a natural flooring option - consider including a weed barrier. Here are a variety flooring options to consider:

- Soil - this is a great option if you have fertile soil and wish to plant directly into the ground. This can be used in combination with other options below.
- Pea gravel, crushed stone, etc. - provides natural drainage and some crushed rocks help with weed control
- Pavers and bricks - A very nice looking option with natural drainage capabilities. May also be used for paths in combination with in ground planting areas.
- Wood - Looks very nice, but requires more maintenance. Keep in mind that the wood may deteriorate before the greenhouse lifespan is over.
- Full concrete slab - This can double as your anchoring surface as well. Keep in mind that greenhouses can be wet environments so texture and drainage need to be considered.
- Tiling - this can be a beautiful option as well. If your greenhouse is a functioning greenhouse, consider water drainage. Tile may get very slippery when wet.

Water and Electricity

You may choose to bring water and electricity into your greenhouse. If possible, it is recommended to plan for this ahead of time so that you can plumb/wire underneath the base frame of the greenhouse. Generally users will bring electricity under the frame at the most convenient location and then attach conduit to the frame of the greenhouse to the desired location. Custom matched spray paint is available if needed.

If you order an optional irrigation/misting system it may be directly plumbed or attached to a hose with a hose clamp (available at garden stores). The hookup end of the irrigation pipe will be at one of the gable ends, near the ridge. It is helpful to purchase a hose timer so watering can be automated.

Ventilation and Cooling of Greenhouse

Glass greenhouses are effective at heating up quickly on summer days. If you discover your greenhouse is becoming warmer than you desire, here are some options for cooling.

- Shadecloth - roller shades or exterior shadecloth
- Exhaust Fan - recommended to be installed in the gable of the greenhouse to blow out the hottest air. Replace a glass pane with a lexan panel into which you can mount the fan. Many exhaust fans will use an external thermostat to control at what temperature it turns on and off. Place the exhaust fan opposite your louver window to create a cross breeze. For the most effective cross breeze, it is often recommended to close window vents to force airflow through your louver window.

- Misting System - in dry environments, a misting system turning on at the hottest point of the day can cool a greenhouse up to 15 degrees.
- Tinting - Aftermarket tinting may be applied to the glass panes
- Whitewash - available from some greenhouse retailers, this can be washed off when the hot season is over.
- Exterior shade cloth - an exterior shade cloth, though not as beautiful, can be highly effective. An aluminet shade cloth is a metallic woven shade cloth that goes up and over the outside of the greenhouse. The metallic surface reflects the heat of the sun's rays before they get inside the greenhouse, while also providing shade.

Heating the greenhouse

Although the greenhouse heats up quickly during sunny days, you will likely find you will need to provide supplemental heat during cold winter nights and cold cloudy days.

- Heaters - electrical, propane and wood stoves have all been used. Be sure to properly vent according to manufacturer instructions. Find a BTU calculator online to determine how powerful a heater you need. This is based on a variety of factors including greenhouse material, size, location/climate, low temperatures and desired goal temperature.
- Heat Sink - The more mass you have inside your greenhouse, the more heat can be absorbed during the warm day to release at night. This can help mitigate huge temperature swings during light frost, but can also reduce your heating costs. Easy ways to add mass that can retain heat are raised beds, a large dark water tank, or organic material. There is much information online about planning/designing more in depth heat sinks in your greenhouse - including flooring choices.
- Resources on insulated floors and geothermal heat can be found on many garden blogs.

Can I Use My Greenhouse as an Additional Living Space?

- These structures are designed to be a greenhouse first and foremost. As packaged, the greenhouse is not designed to be water/air tight. Greenhouse plants do benefit from a turn of air. You will need to do some extra sealing with silicone on the roof around the glass to achieve watertightness.
- We recommend any furniture be indoor/outdoor and that fine wood furniture/electronics be avoided or sufficiently protected.
- The glass is single pane, so there is a good chance for condensation on the inside that might drip. The roof windows do have auto openers, so it is likely the roof vents will be open during a rainstorm if the temperature in the greenhouse is above 68 degrees. You can switch to all manual openers if preferred.
- On sunny days, glass greenhouses can get warm very quickly. Depending on your climate, you will likely be fighting the heat in the summer (late spring/early fall).

It has been done, but you will need to make customized adjustments such as extra sealing, climate control, window tinting and heating. Indoor/outdoor furnishings are strongly recommended. Exaco will not be held responsible for any damages.

Maintenance of Greenhouse

The following will help keep your greenhouse in tip top shape:

- **WINTER/SNOW/ICE CONSIDERATIONS:**
 - The roof will need to be cleared of snow, this removes weight from the roof and also allows the sun to shine in and heat your greenhouse
 - Heating your greenhouse may also help some of the snow melt/slide off to assist in keeping the roof clear. If you are heating the greenhouse, you may wish to disengage your pistons so the roof vents do not open.
 - If you are expecting heavy snowfall that you will not be able to clear in a timely manner, we recommend bracing your roof with a 2x4 to help support the weight. Snow should still be cleared as soon as it is possible.
 - If you are in an area that routinely gets significant snow there are some options to strengthen and support your greenhouse:
 - Install self-tapping screws in addition to the bolts where the rafters meet the ridge beam and the gutters (noted in assembly manual).
 - Add a stainless steel cable with a turnbuckle connecting opposite sidewalls/spandrels to prevent the sidewalls from bowing out if there is excessive weight on the roof.
- Pistons and openers - Several times each year oil your piston rods, threading, and moving parts of your openers. You may use WD40 or even olive oil. If your pistons stop opening your windows, you likely need to oil them to loosen them up.
- Glass Maintenance
 - Cleaning Glass - use a gentle cleaner, such as Palmolive dish soap with a soft cloth. A squeegee with a long handle is helpful as well. Distilled white vinegar can be used to remove hard water spotting.
 - Replacement Glass - if you need to replace a piece of broken glass, please refer to the glass spec sheet in this manual. Replacement panes of 3/16" standard tempered safety glass should be ordered from a local glass shop. Exaco will not ship large pieces of glass, locally ordered replacement panes of standard tempered safety glass will match the original panes.
- Polycarbonate Cleaning - use a gentle cleaner, such as Palmolive dish soap with a soft cloth.

Questions? Need Assembly Support?

Please call Exaco at 877-760-8500 or email customerservice@exaco.com.

" MODERN "

	A	X	B
M23	93 inches (2360mm)		122 inches (3098mm)
M34	122 inches (3098mm)		180 inches (4574mm)
M36	122 inches (3098mm)		238.2 inches (6050mm)

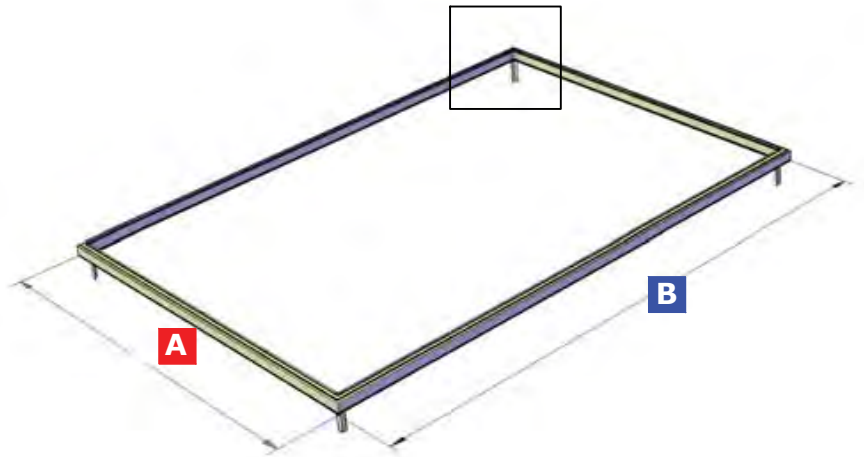

IMPORTANT!
Do NOT pour concrete into anchors until frame is assembled and level.

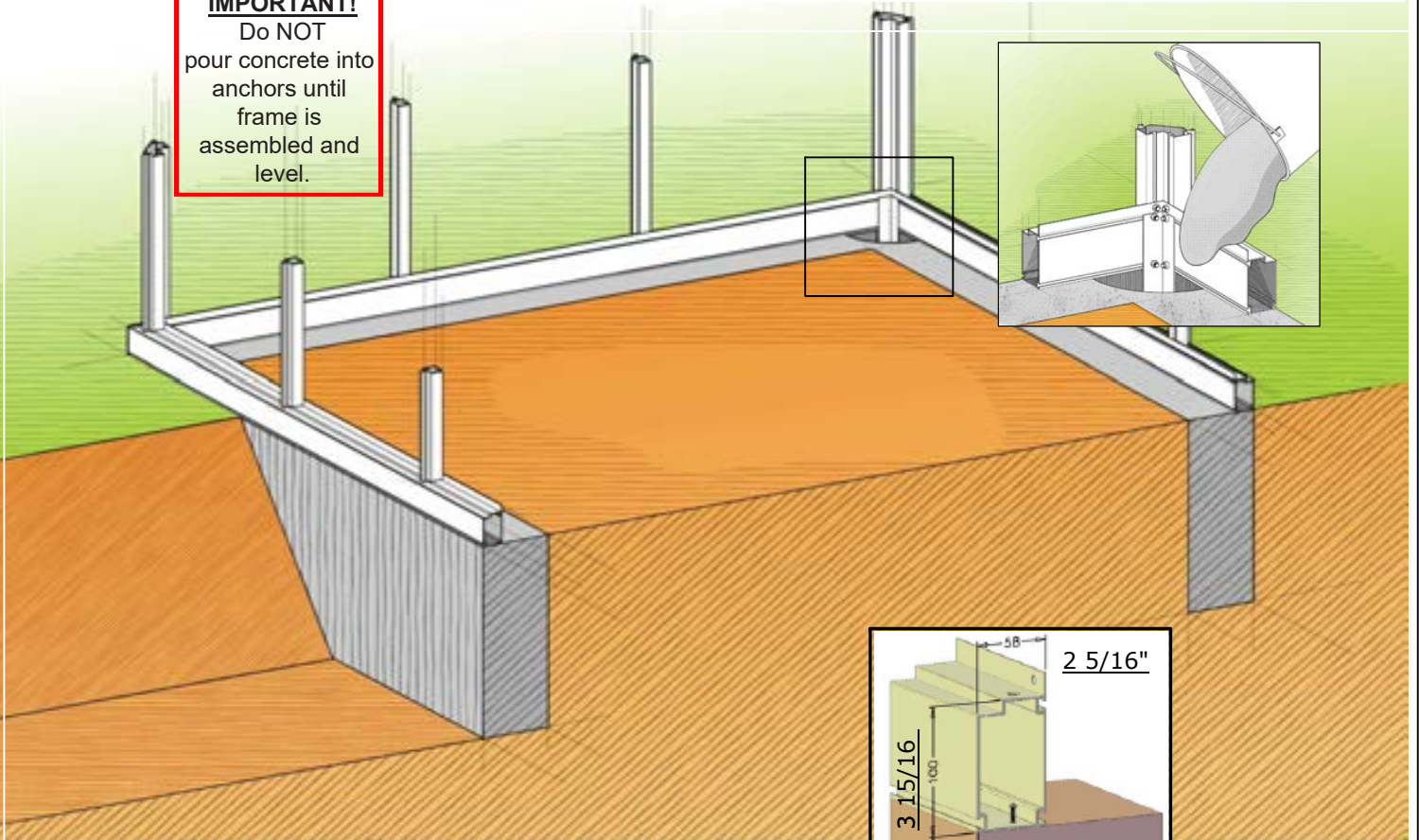

Important notes for preparing your site:

- Do not set anchors in concrete until the entire greenhouse frame is complete, level, and square. You will need some play to attach the uprights.
- It is recommended to build your foundation down to the frost line in your area. Consult with a local contractor for recommendations
- Greenhouse base frame is 2.25" wide
- Corner anchor posts are 1.5" x 1.5". They attach at the interior corners of the base frame, then extend 12" below ground. Bolts are attached to the bottom of the anchor to be a "catch" in the concrete. We recommend leaving a 4-6" hole in your concrete for the anchors. Do NOT embed the corner anchors into concrete until the greenhouse is built, leveled and square.
- Embedding the corner anchor into concrete is the most secure method, although you may choose to trim them off and cut them into halves or thirds and use them to attach the greenhouse to the foundation frame/concrete with stainless-steel concrete screws.

OPTION: Building a stem wall for your greenhouse

Door extension kit is required - All dimensions are external dimensions of the aluminum profiles

Example Only
Diagrams for your model may have greater/fewer panes

Height of your choice

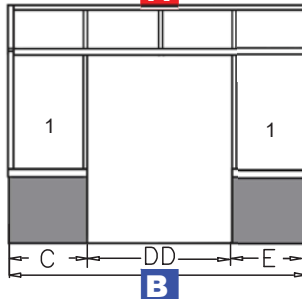
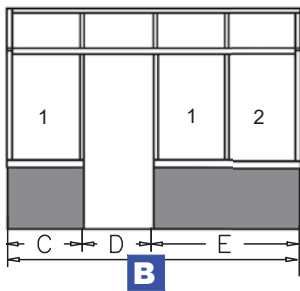
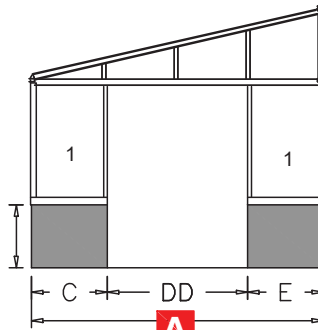
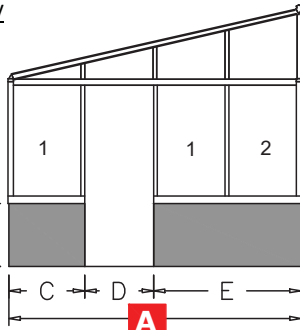

A = Gable end length if placing door on gable

B = Side length if placing door on long side

C = Measurement to left of door based on

of glass panes - see diagrams in intro for your greenhouse if unsure

D = Rough opening for SINGLE door

DD = Rough opening for DOUBLE door

E = Measurement to right of door based on # glass panes

Measurements are in millimeters for precision. Please use combination tape measure in your kit.

DOUBLE CHECK YOUR MEASUREMENTS:

A OR B = C + D(OR DD) + E!!!!

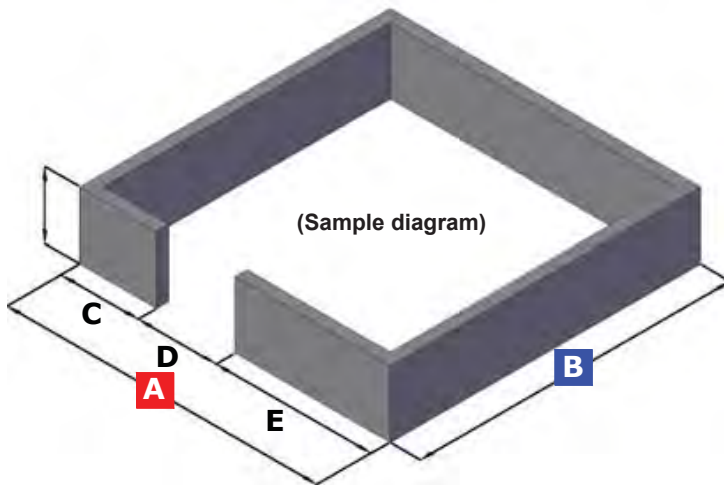

A (gable) = 2360 | 3098 | 3836

B (side) = 2360 | 3098 | 3836
4574 | 5312 | 6050

C = 1 pane = 829

2 panes = 1567

3 panes = 2305

4 panes = 3043

D = 703 (**DD** = 1441)

E = 1 pane = 829

2 panes = 1567

3 panes = 2305

4 panes = 3043

A OR B = C + D(D) + E !!!

Notes about stem walls:

- Read notes on previous and following pages to understand anchoring options, and measurements of frame for thickness of your wall.
- Your doorway may be placed on the gable end or long side.
- Stemwall height is determined by you, maximum height with standard kit is 30".
- All measurements are external dimensions of the aluminum profiles.
- You will need a platform to install the 11' long roof panes of glass. This will require (2) people to help ensure safety.

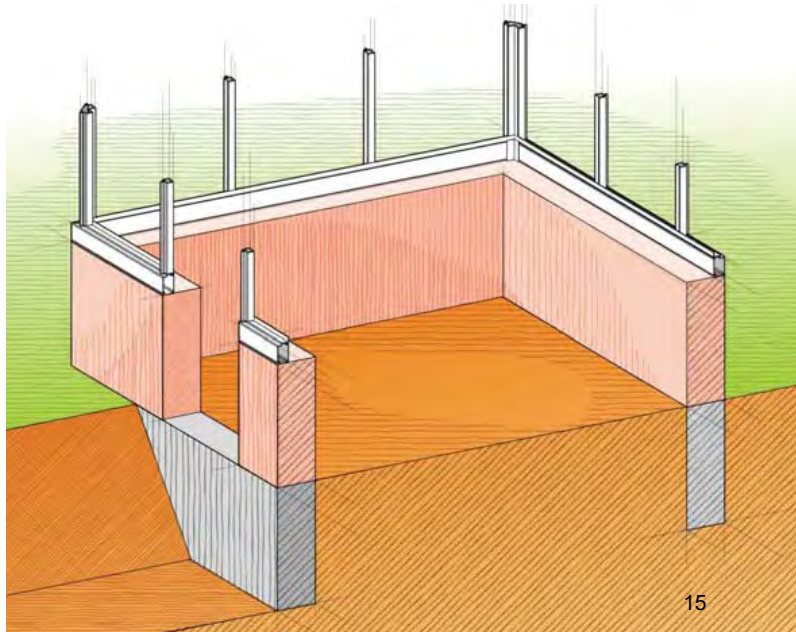

Hinged door extension installation - View from inside Greenhouse

Can be installed on long or short gable end of greenhouse
(see door considerations for VI36/VI46 at front of manual)

(Single)

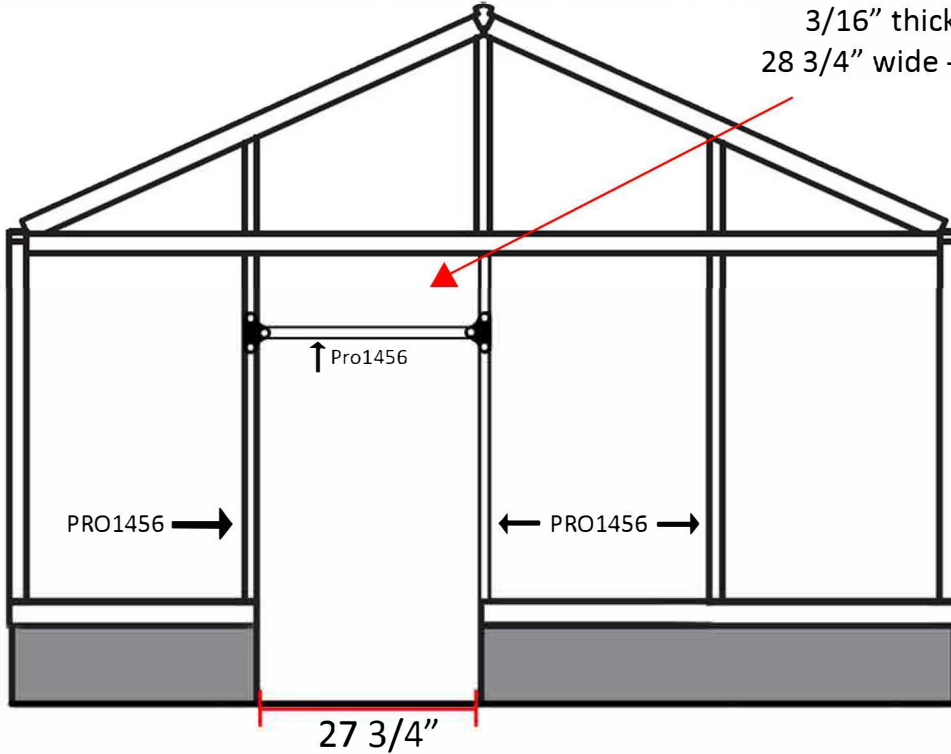

-Opening will be 27 3/4" or 703 mm wide

Kit will include:

- (1) PRO1456
- (2) 3-Hole Brackets
- Nuts & Bolts

Glass for header must be ordered locally due to custom wall height
3/16" thick tempered safety glass
28 3/4" wide -height determined by wall

(Double)

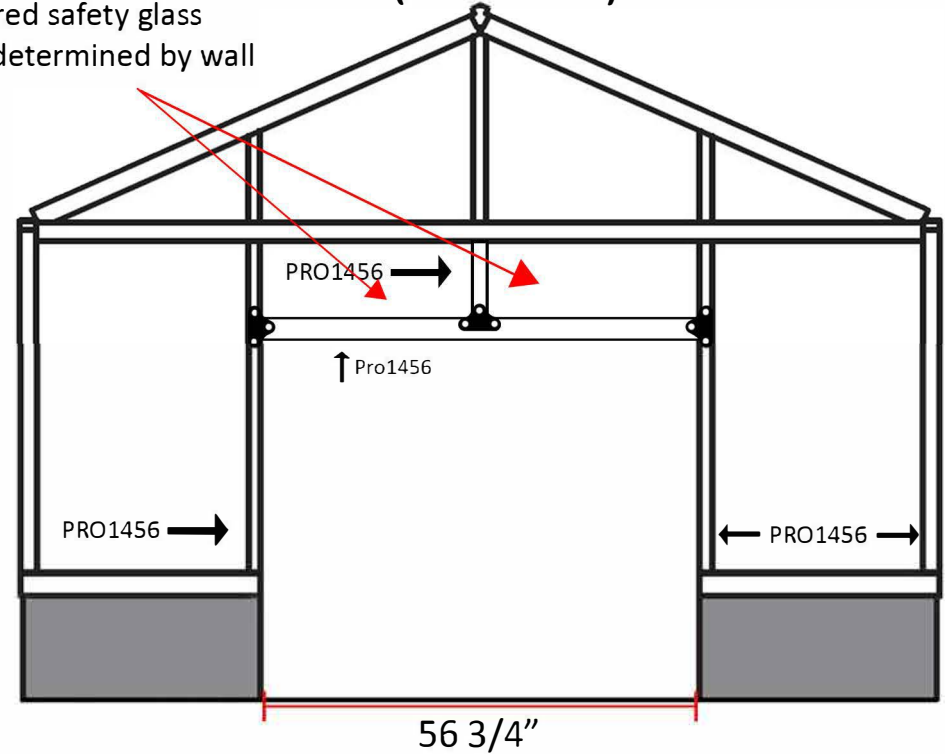

-Opening will be 56 3/4" or 1441 mm wide

Kit will include:

- (1) PRO1456
- (1) 30" Pro1456 (cut to match the height of stem wall)
- (3) 3-Hole Brackets
- Nuts & Bolts

Hinged door will include its own door jamb - place the horizontal PRO1456 on top of the door jamb.
move to manual for door¹⁶ assembly & installation

Sliding door extension installation

Can be installed on long or short gable end of greenhouse

(Single)

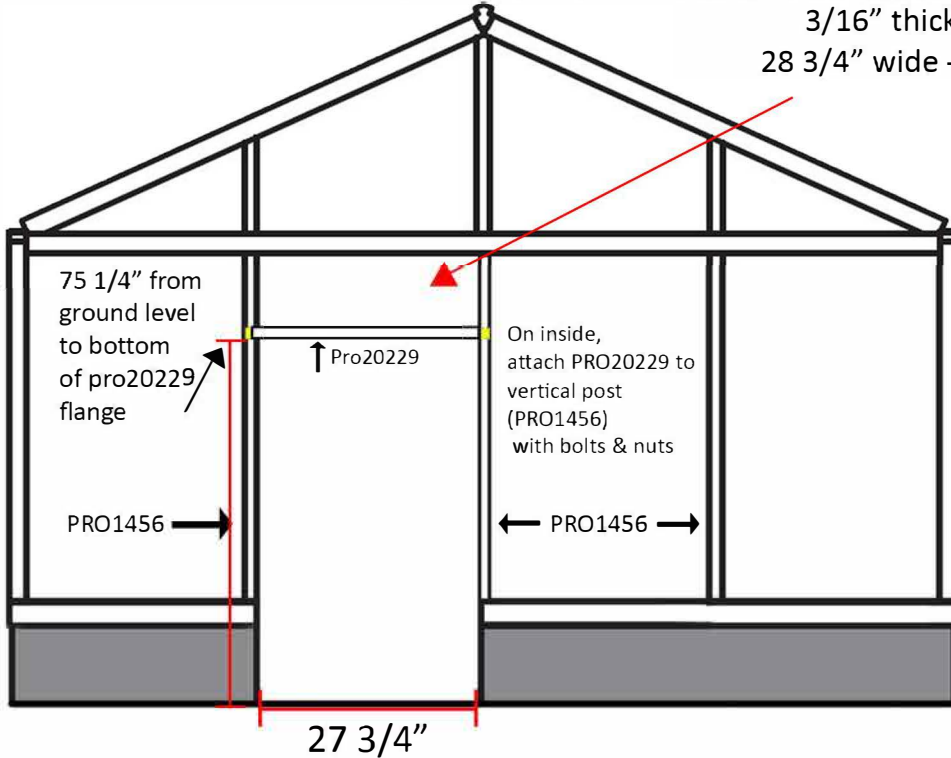

-Opening will be 27 3/4" wide

Kit will include:

- (1) Pro20229 w/ flanges
- Nuts & Bolts

(Double)

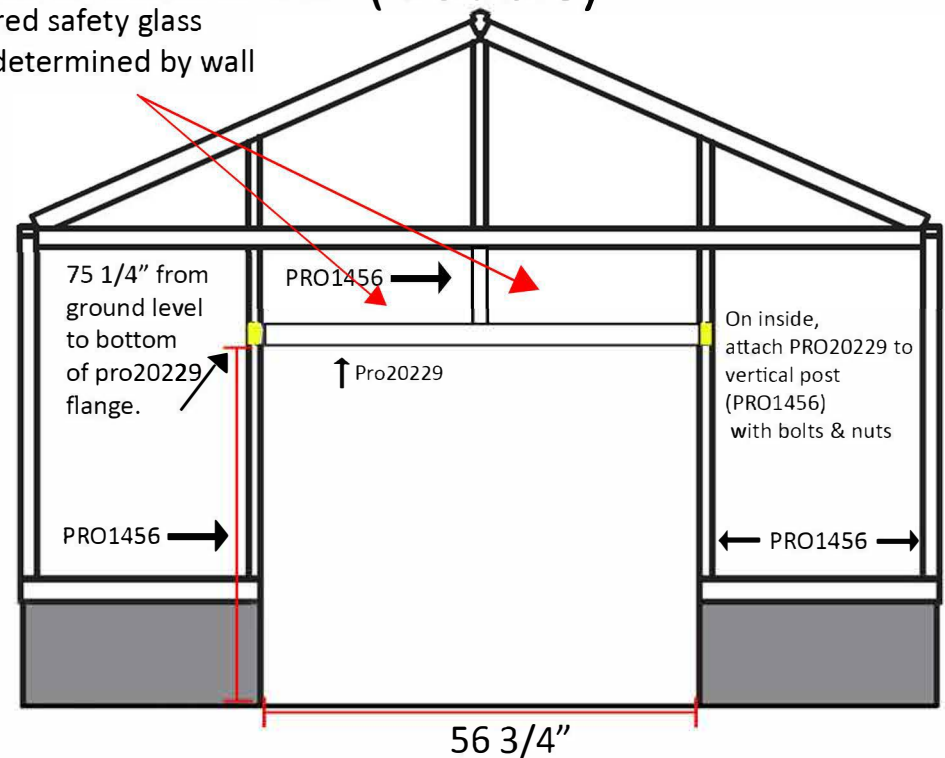

-Opening will be 56 3/4" wide

Kit will include:

- (1) Pro20229 w/ flanges
- (1) 30" Pro1456 (cut to match the height of stem wall)
- Nuts & Bolts

After the doorway is framed out - move to manual for door assembly & installation

Glass for the Modern Greenhouses

All glass is 3/16" thick tempered safety glass - 1/4" thick may be used if a local shop cannot do 3/16"

Modern 23 (7'9" x 10'2")

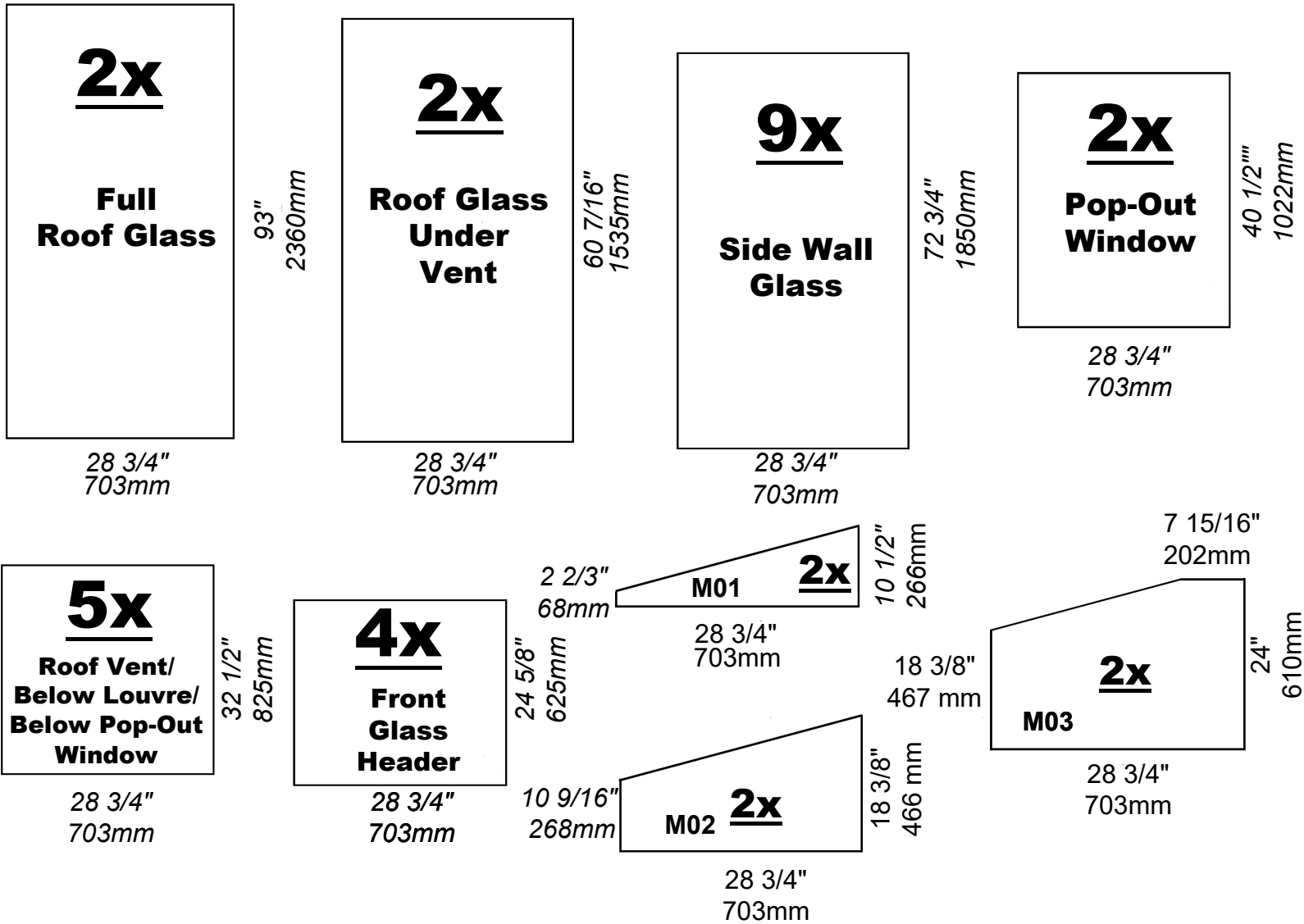

Modern 34 (10'2" x 15")

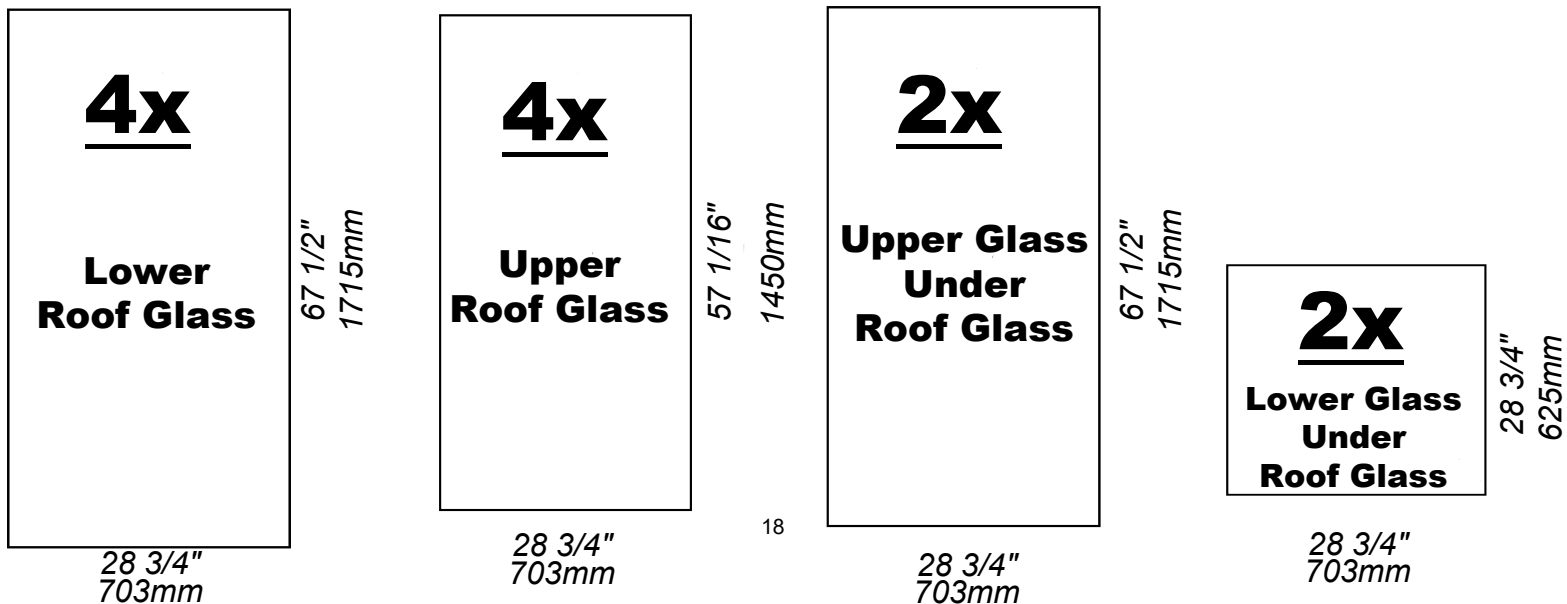

Modern 34 (10'2" x 15")

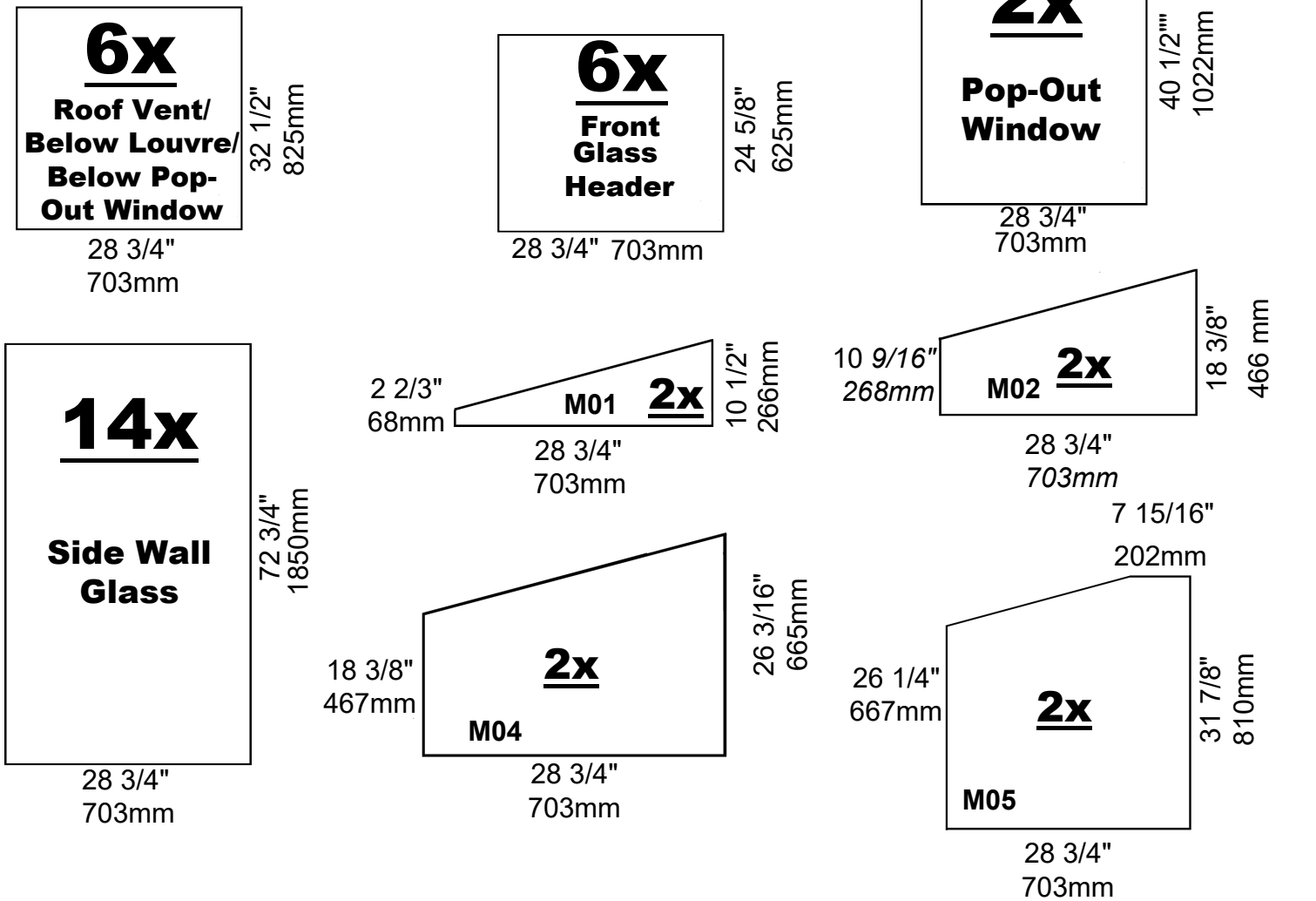

Modern 36 (10'2 x 19'11")

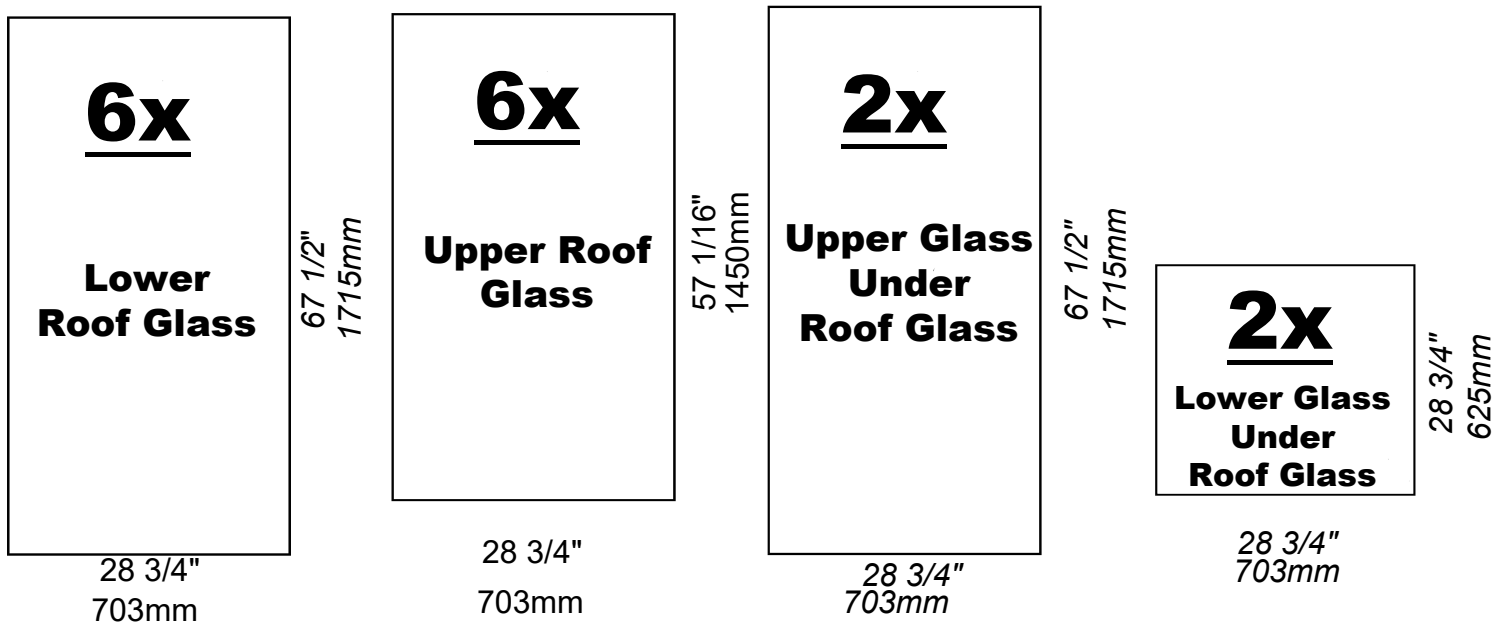

Modern 36 (10'2 x 19'11")

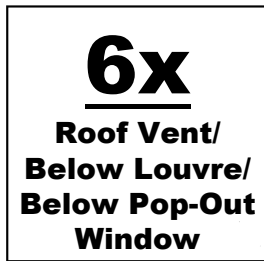

28 3/4"
703mm

32 1/2"
825mm

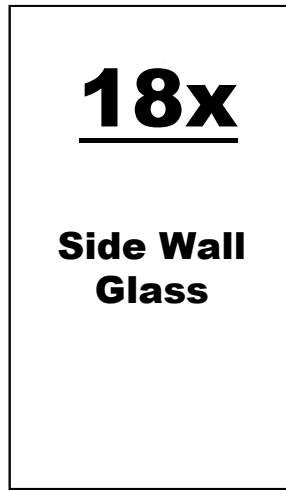

28 3/4"
703mm

72 3/4"
1850mm

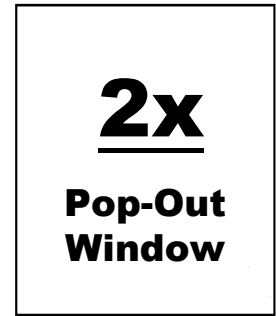

28 3/4"
703mm

40 1/2"
1022mm

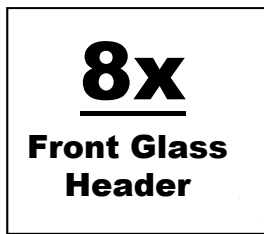

28 3/4"
703mm

24 5/8"
625mm



2 2/3"
68mm

28 3/4"
703mm

10 1/2"
266mm

10 9/16"
268mm

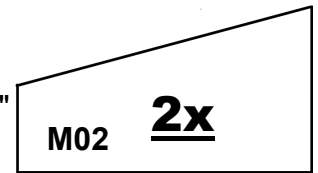

28 3/4"
703mm

18 3/8"
466 mm

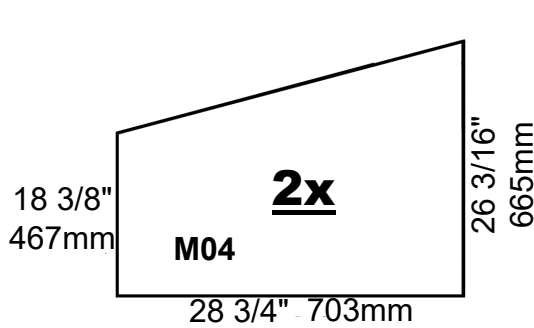

18 3/8"
467mm

28 3/4" - 703mm

26 3/16"
665mm

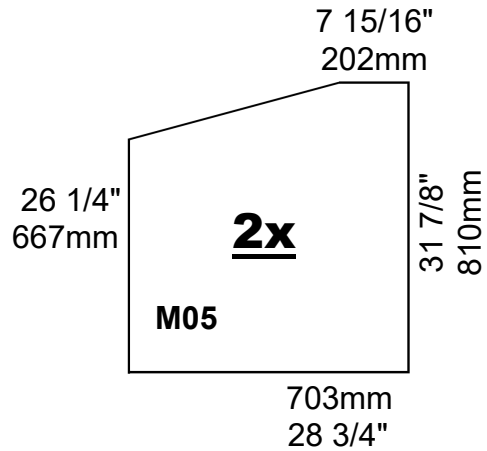

26 1/4"
667mm

703mm
28 3/4"

31 7/8"
810mm

7 15/16"
202mm

Top Plate

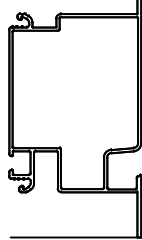

PRO1454

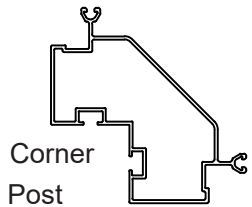

Corner Post

PRO6578



Vertical Glazing Bar

PRO1456



TRE

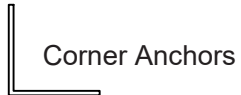

Corner Anchors

PRO210

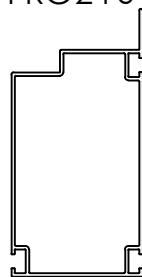

Foundation/Base

PRO210

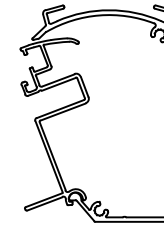

Ridge Beam PRO42786
PRO33329

Roof Glazing Bar

PRO33325

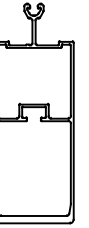

Roof Endbar

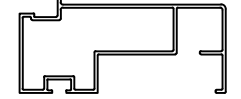

PRO6918

Gutter

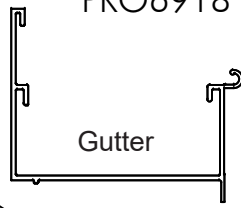

GTO

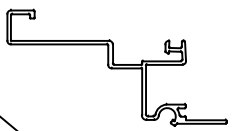

Roof Glass Retainer

GSO

Back Gutter

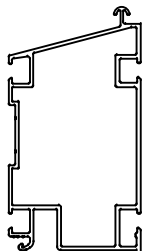

GDO

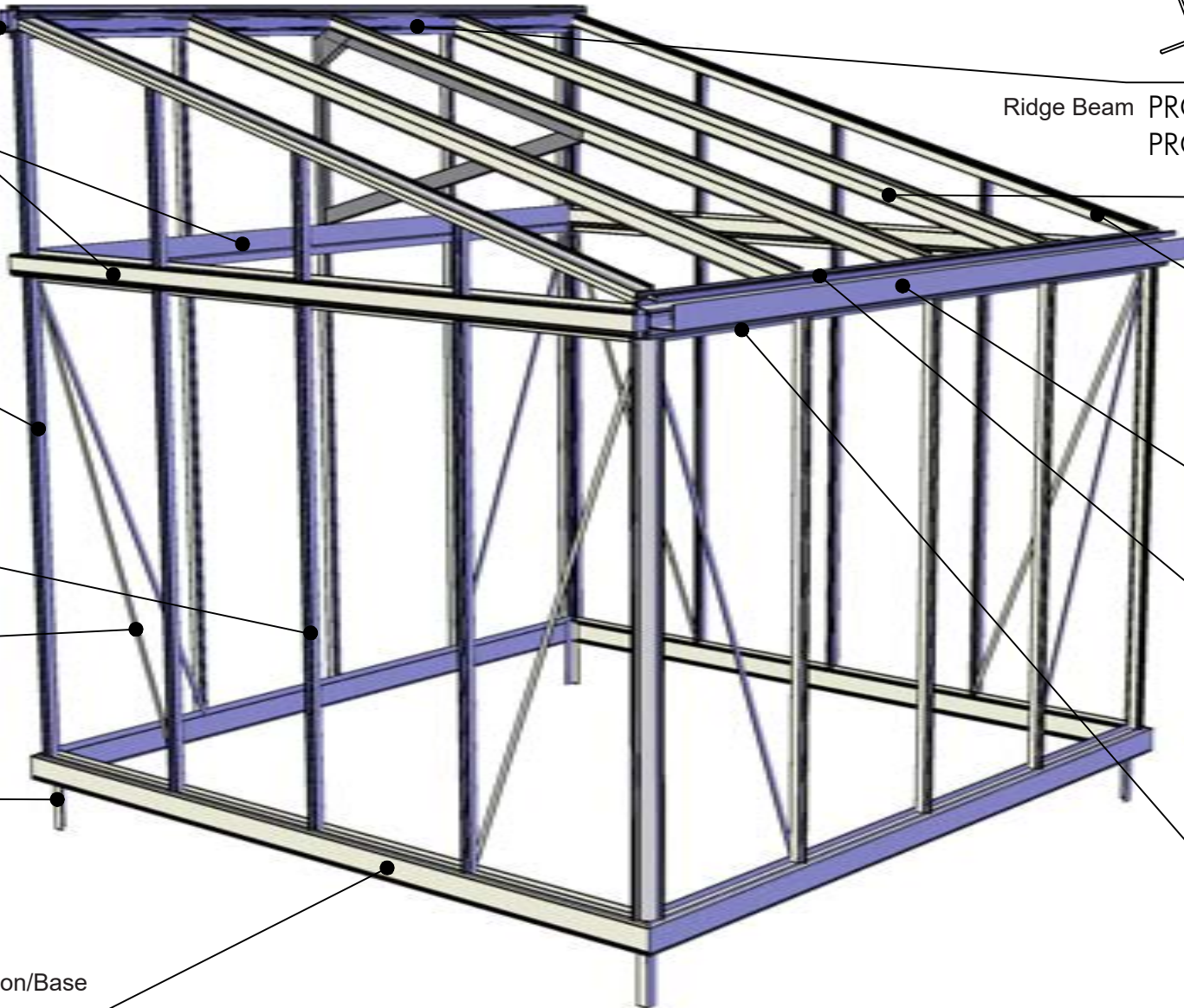

MODERN

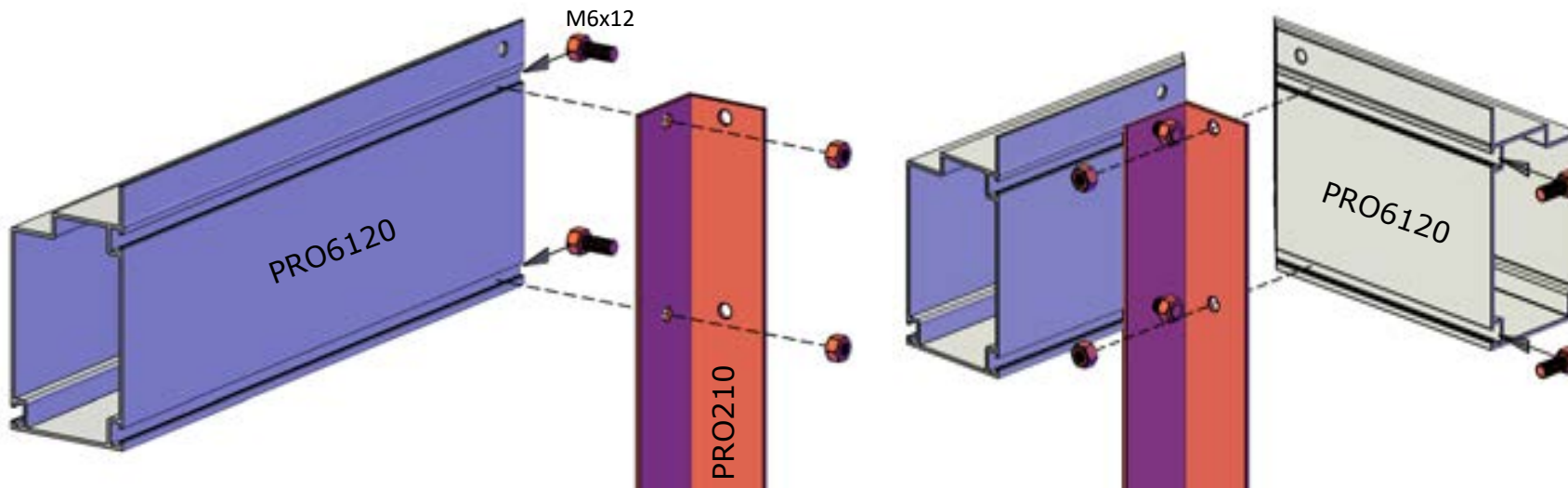

IMPORTANT!
 If you have a single/double sliding door(s). Before attaching, insert 3 M6x12 bolts as for your sliding door guide. You will use 6 bolts for a double sliding door.

Note: When assembling the foundation in this step, only hand-tighten the nuts. The corners may need to be slightly loose to attach the corner uprights (PRO6578).

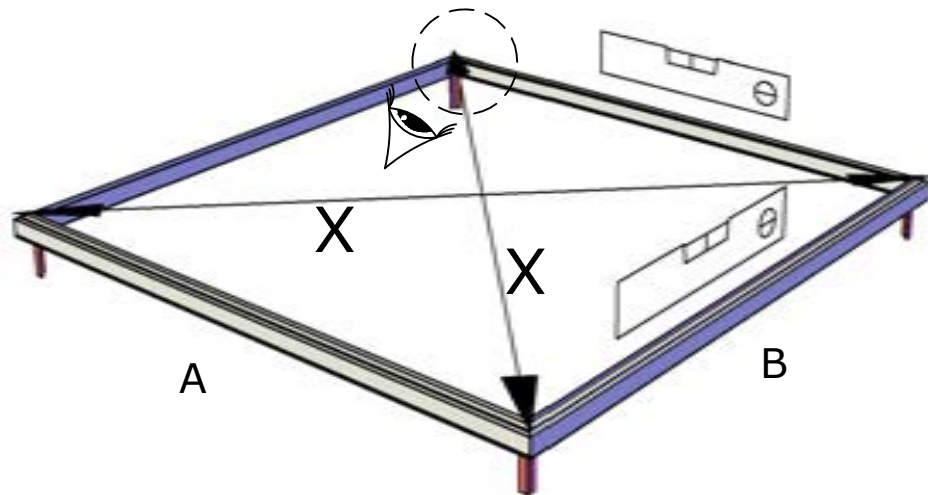
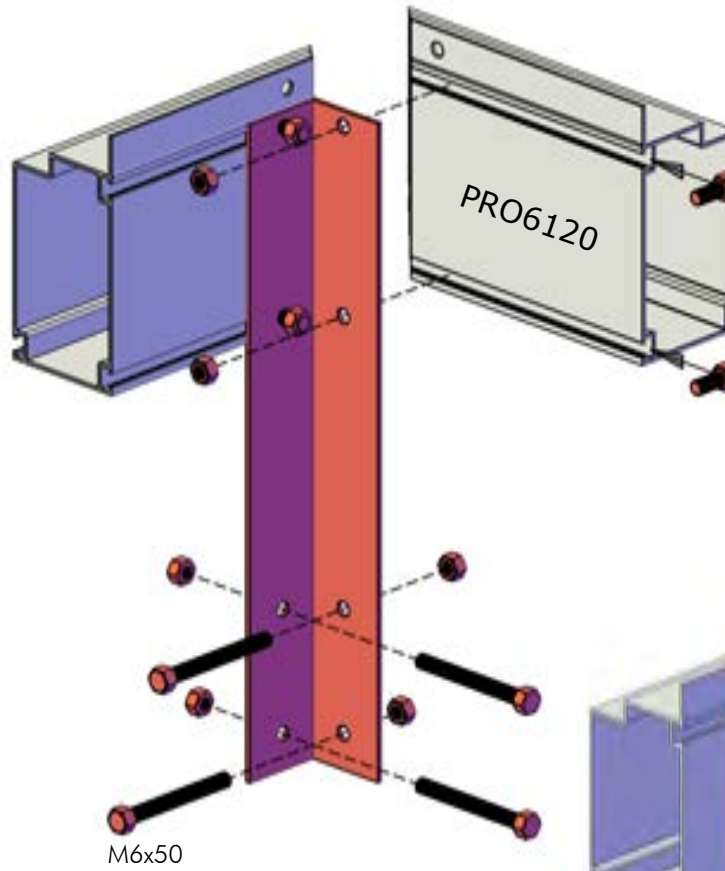

Suggestion: If installed on a concrete foundation you may cut PRO210 flush with the bottom of PRO6120. To anchor, use cut off PRO210 pieces as L-brackets to secure the PRO6120 to the concrete foundation. Please see YouTube animated assembly video for more information. Models that are 19'11" long will include an extra pair of PRO210 anchors.

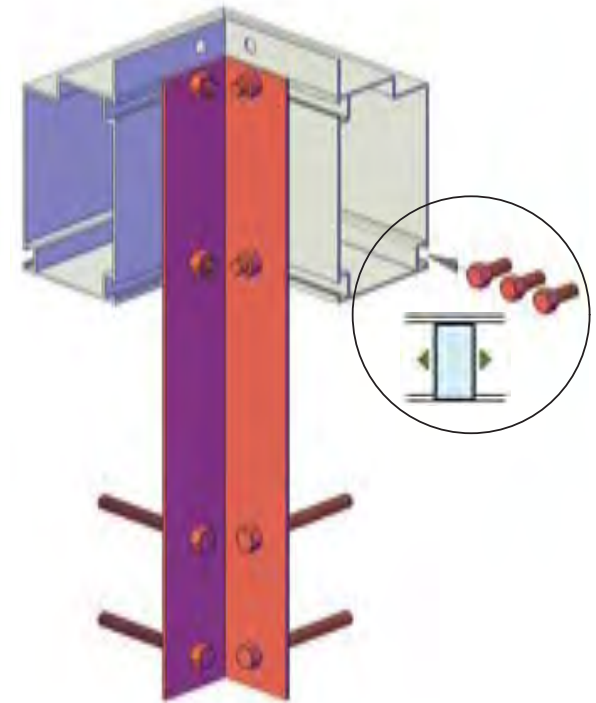

HD (hinged door)

Instructions found on Pages 37-49

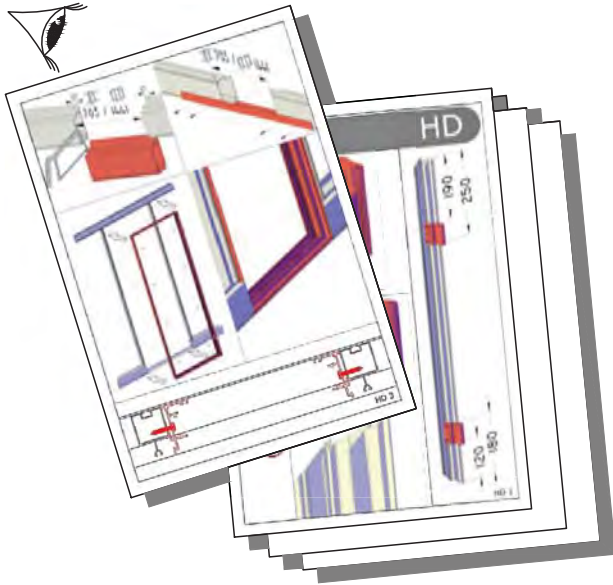
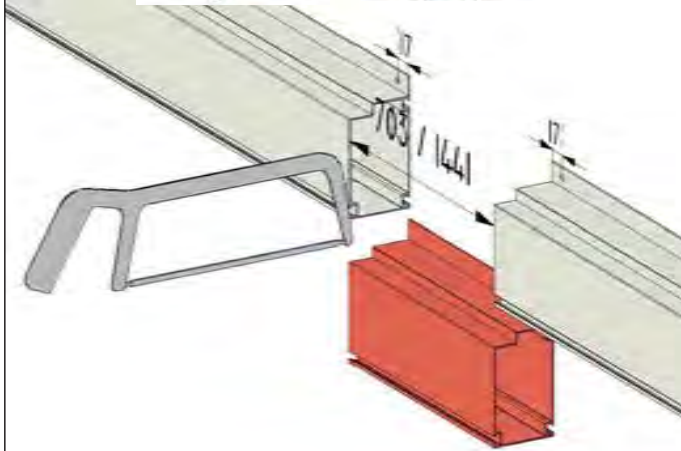
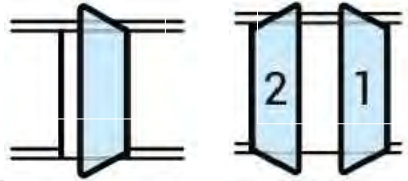

OPTION: KSD (low threshold)

Instructions found on Pages 50-54

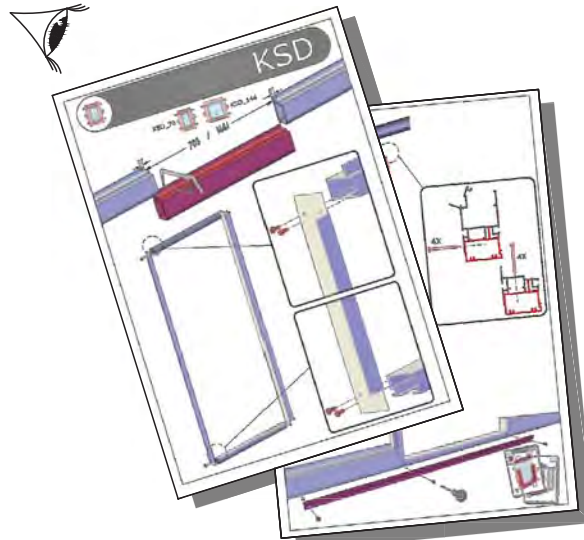
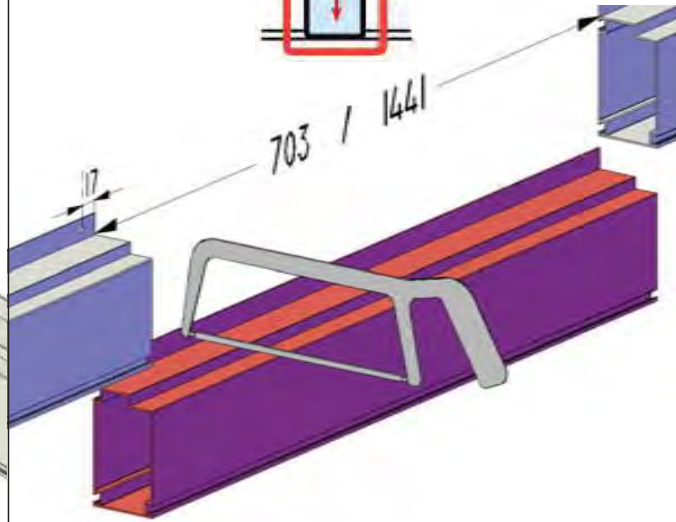
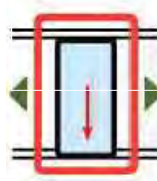

OPTION: SD (sliding door)

Instructions found on Pages 55-60

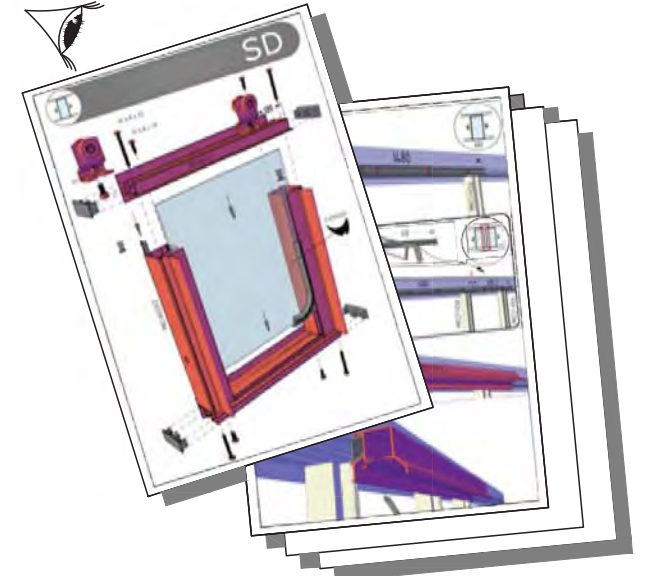
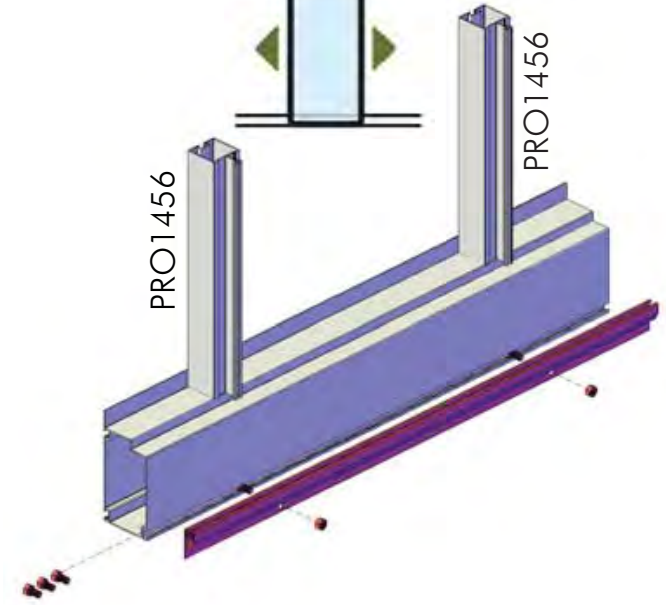
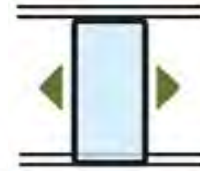

M6x12

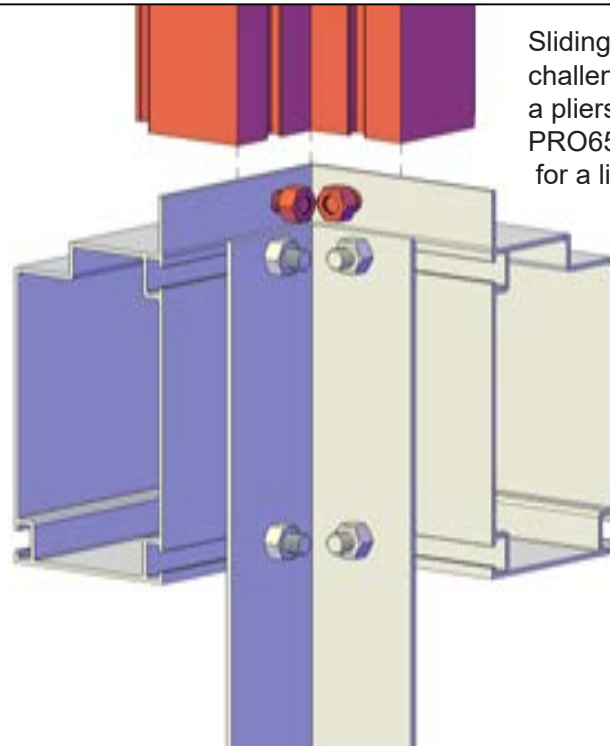
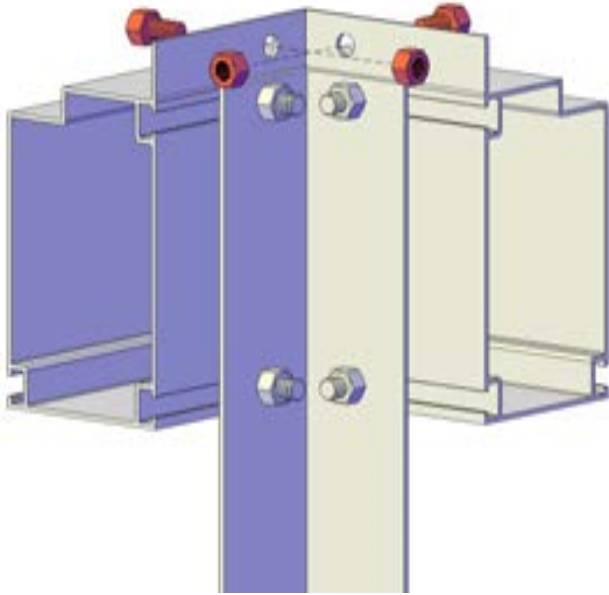

Sliding the corner post (PRO6578) down onto the head of the bolts can be challenging. Use two people: one holds the threaded tips of both bolts with a pliers to position the hexagonal head inline with the channels on PRO6578. It may help to loosen the nuts holding the corner anchor to allow for a little bit of play.

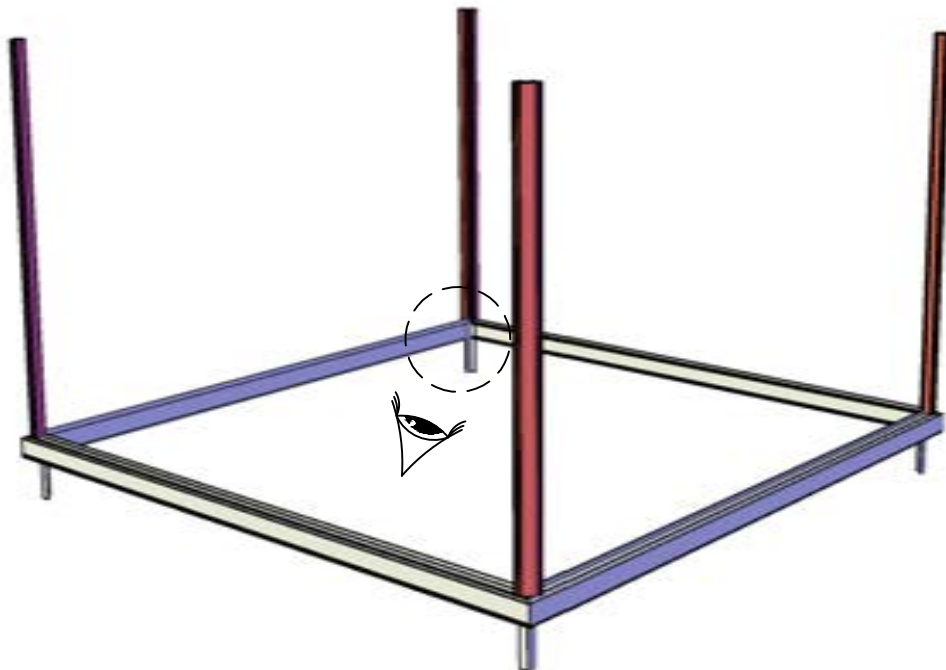

IMPORTANT!

Optional Accessories! Insert a bolt into each corner post channel for where the top shelf and/or Seed Tray will be located. See these pages in the accessories section in the back of the manual.

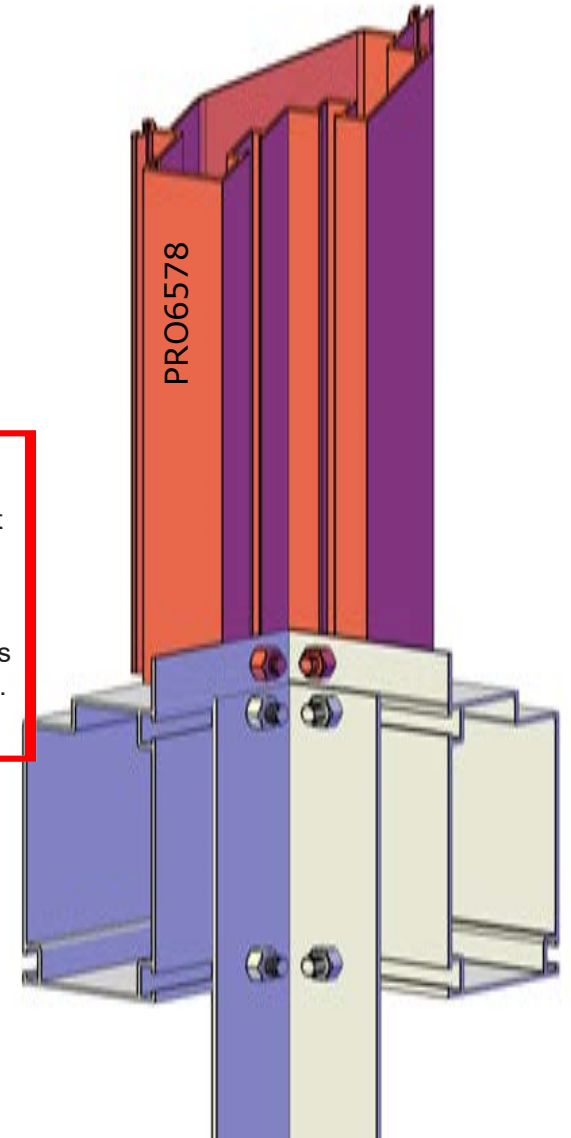

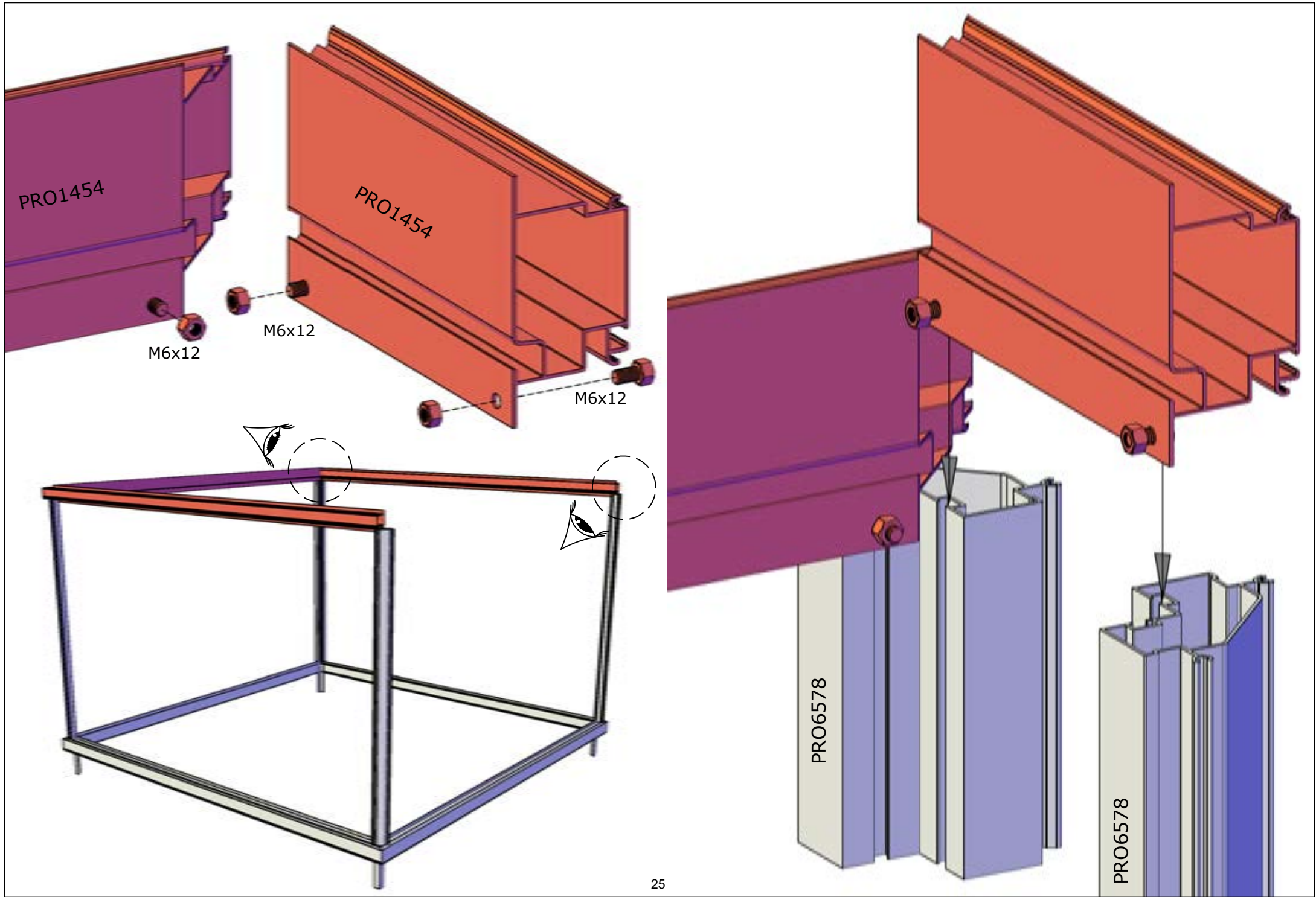

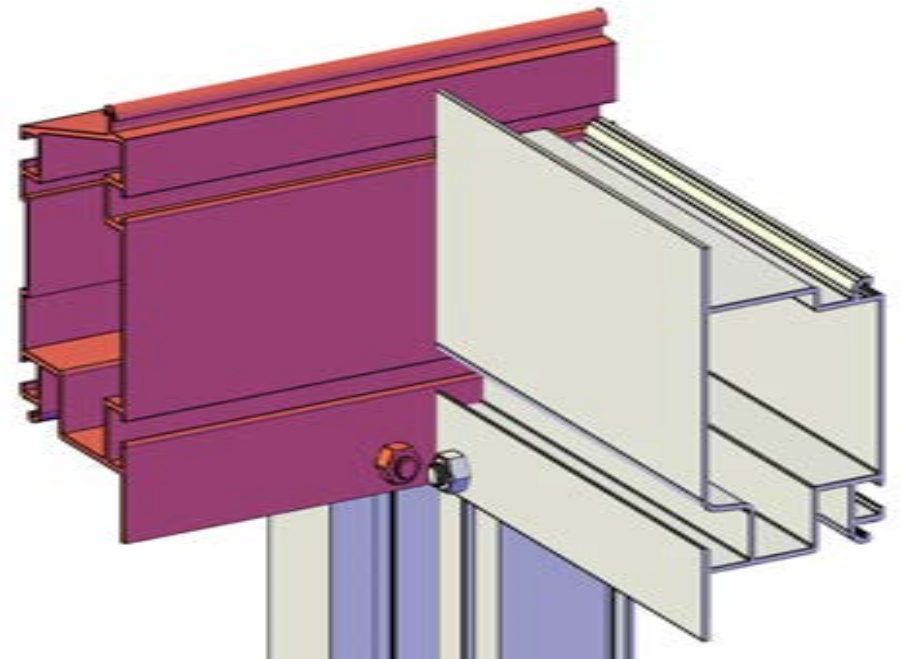
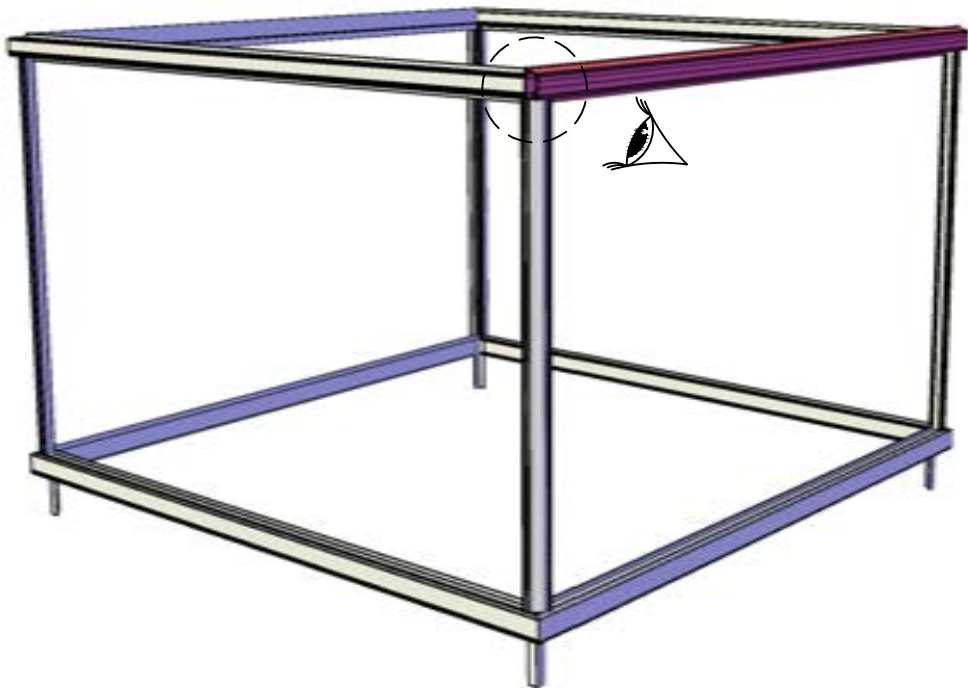
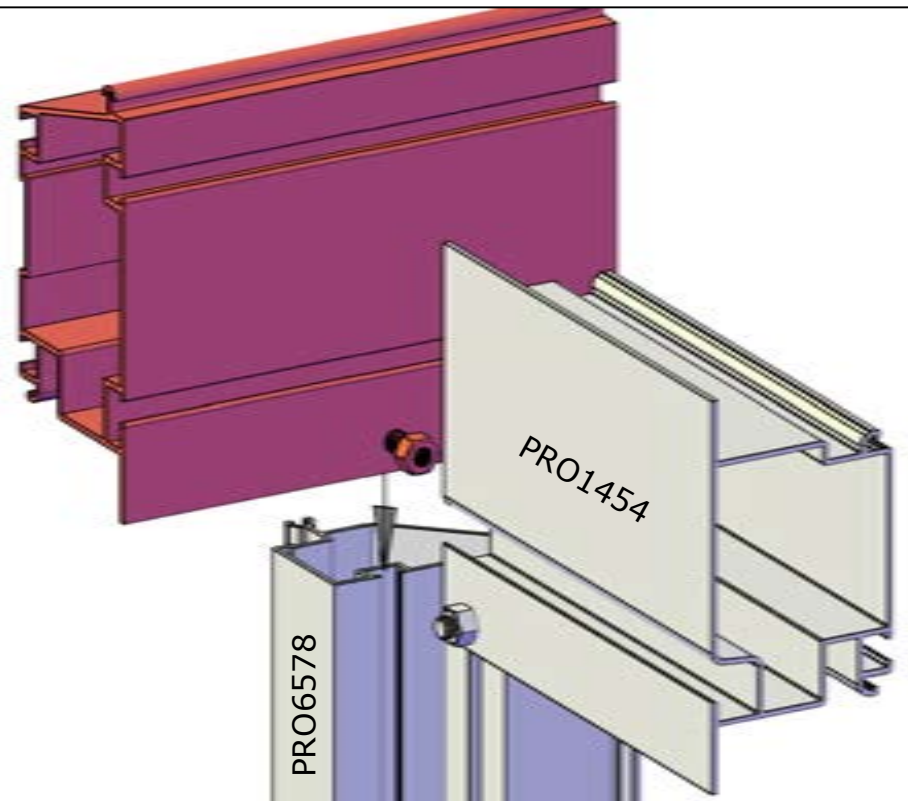
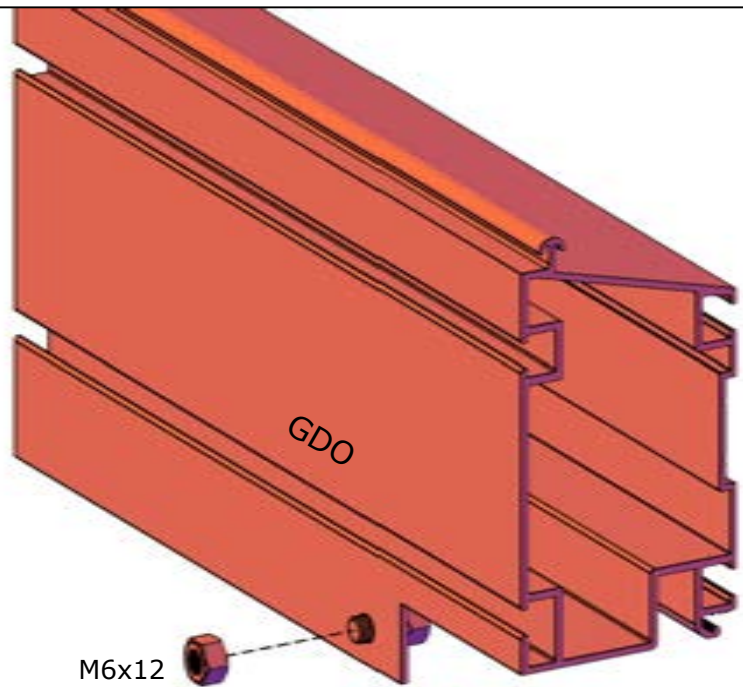

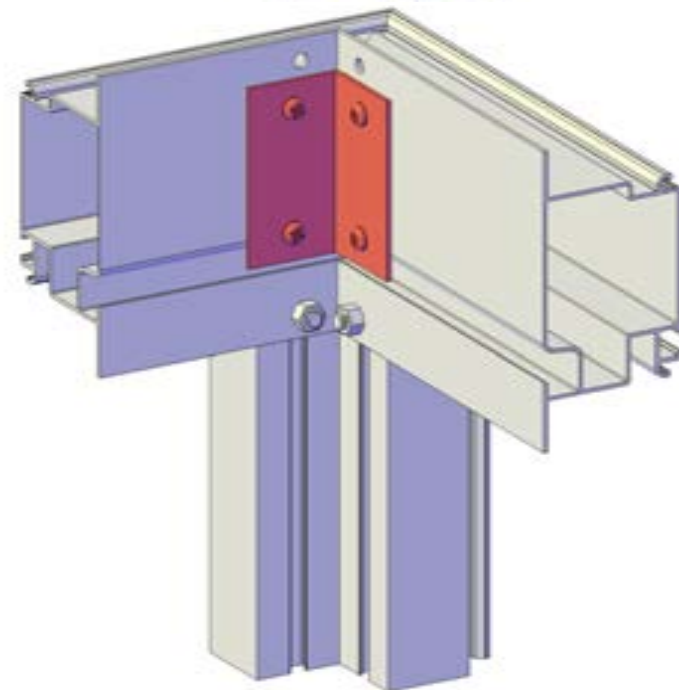
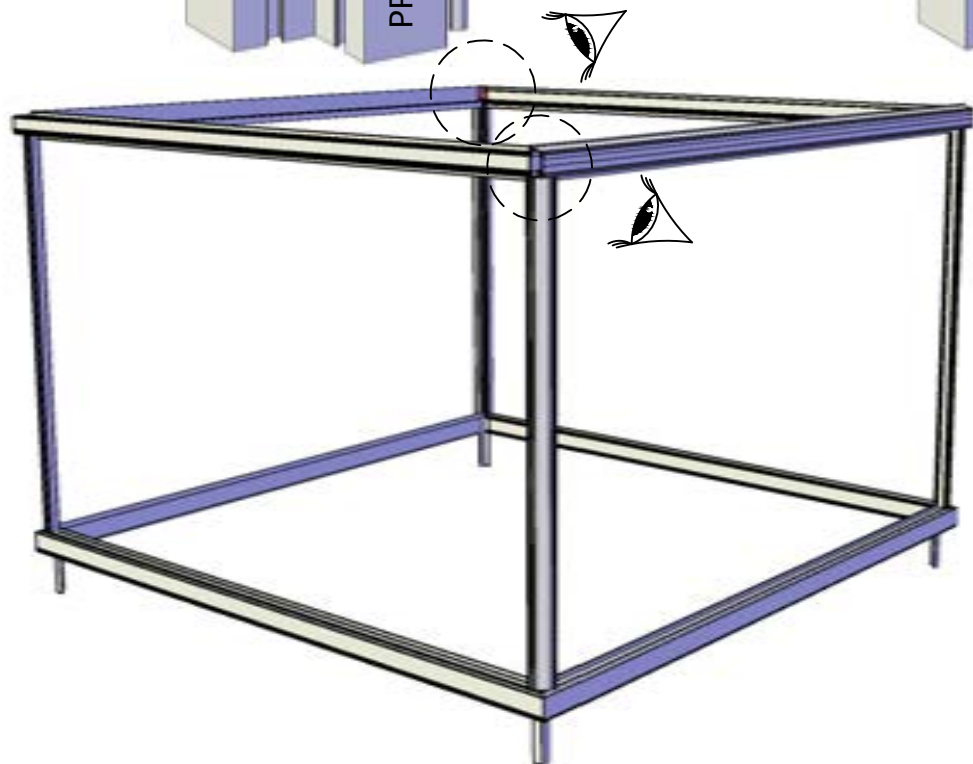
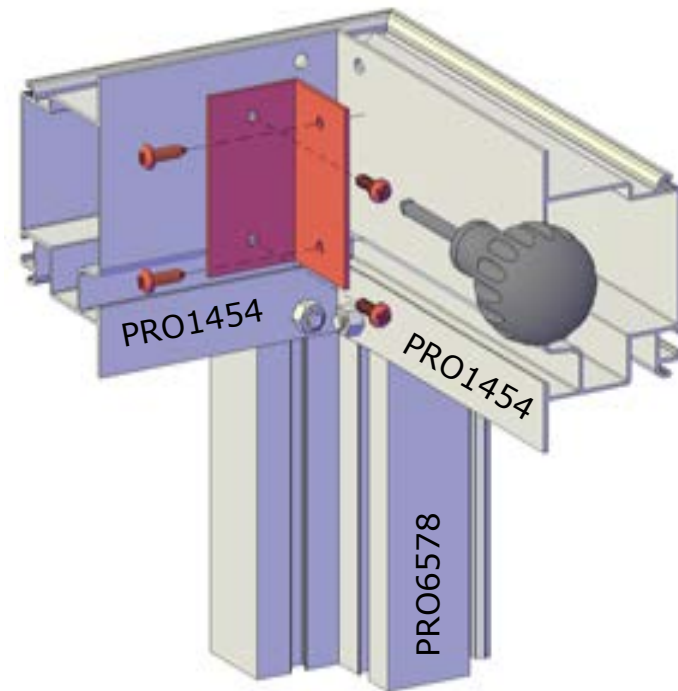
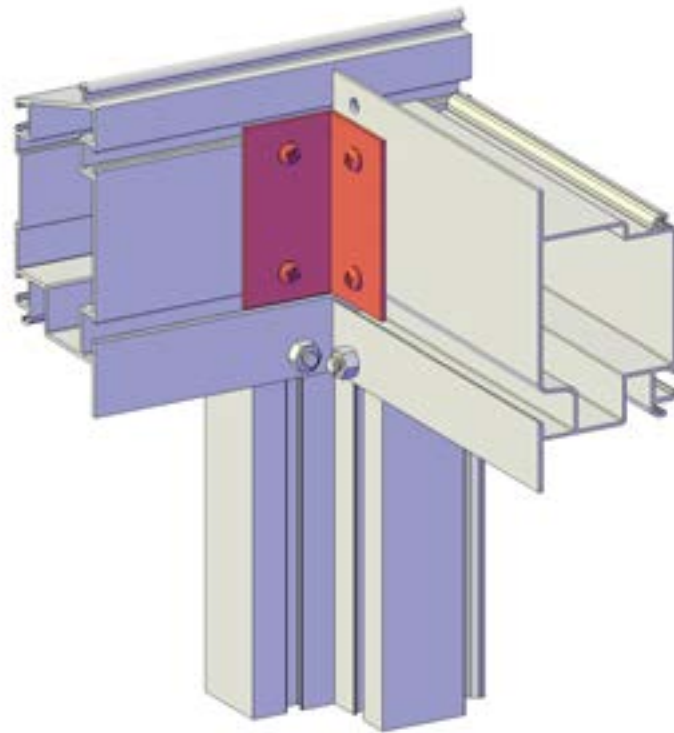
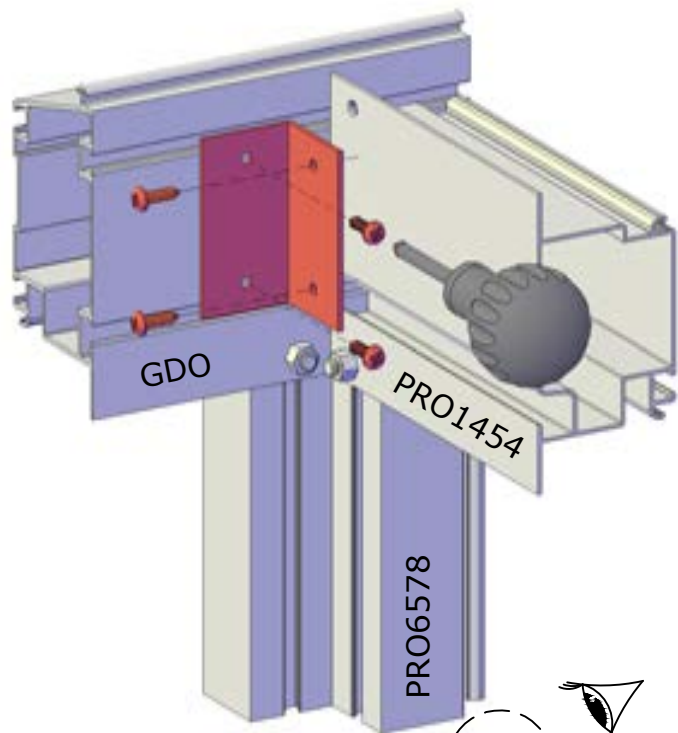

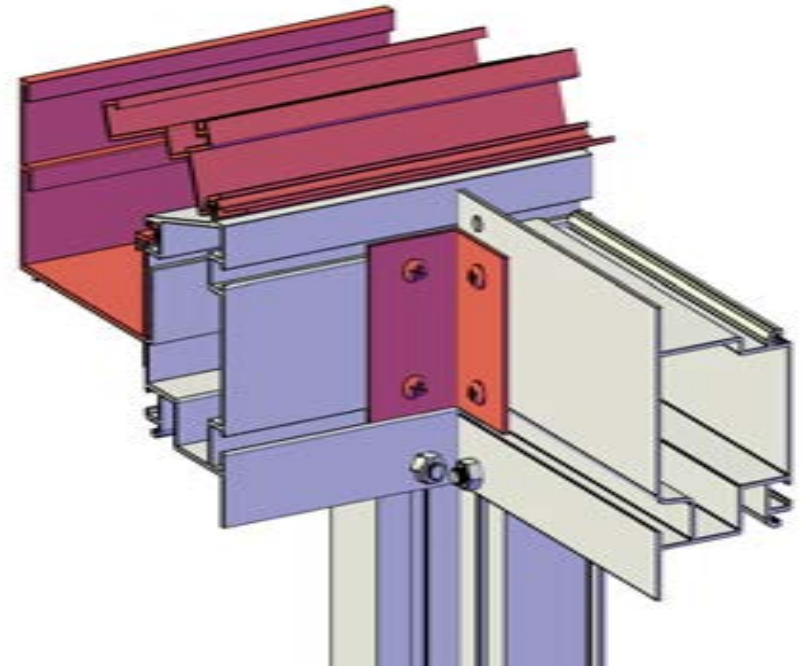
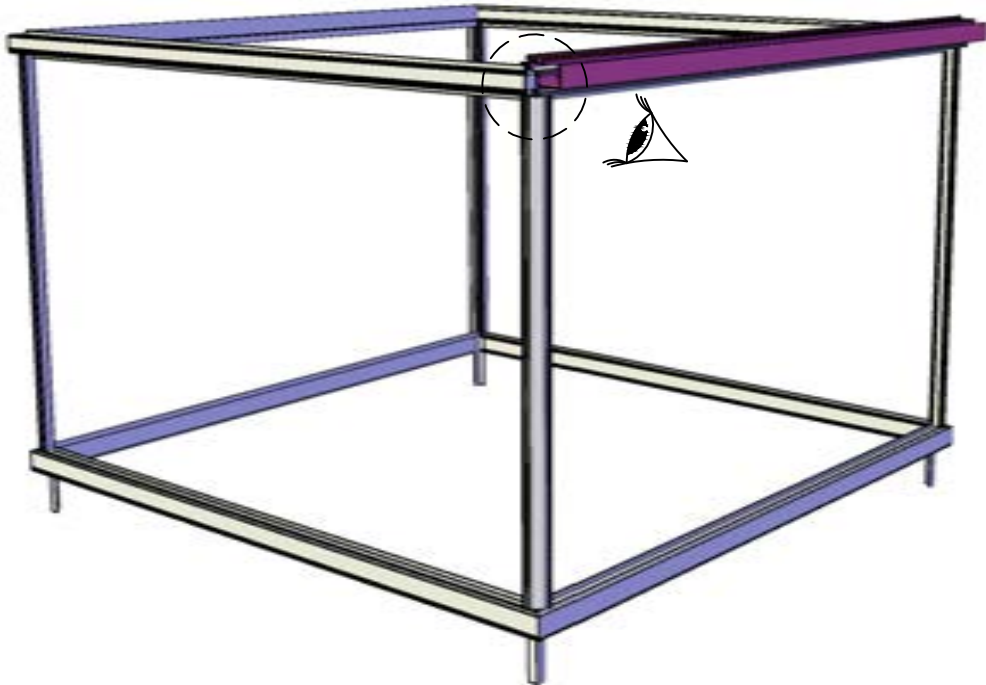
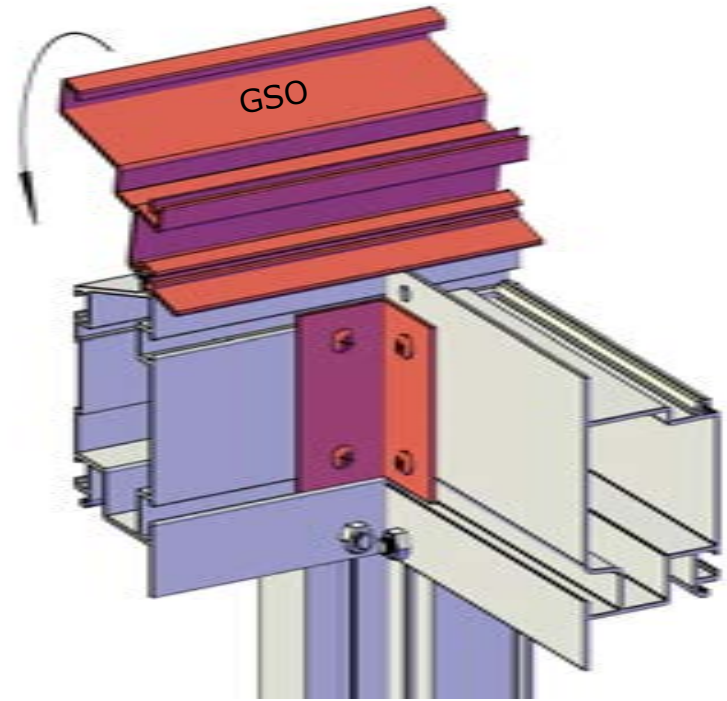
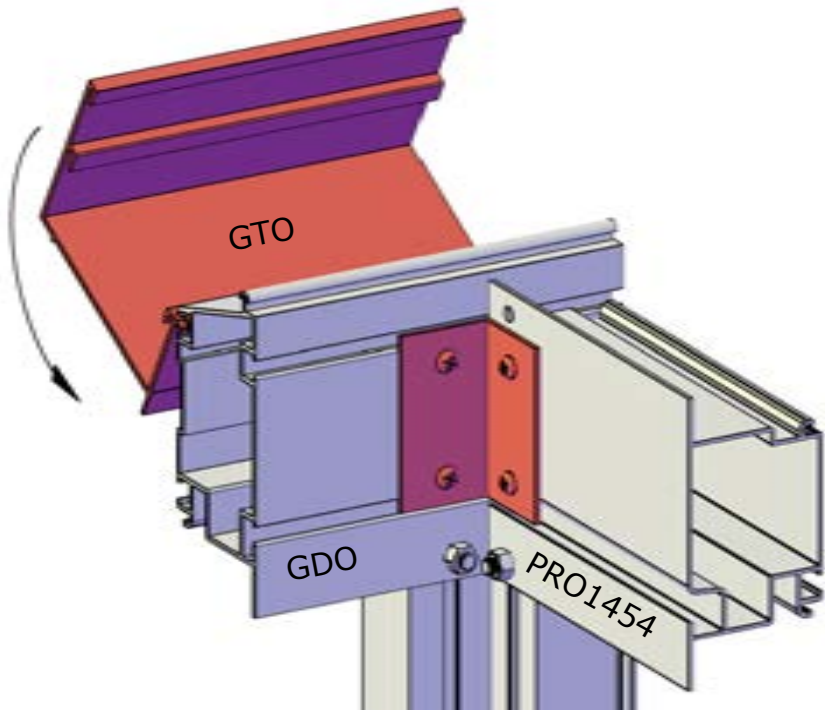

PRO1456

M6x12

PRO6120

GDO

IMPORTANT!

Before securing vertical profiles insert bolts for:

- Louvered Window
- Optional Top Shelf
- Optional Seed Tray

See table of contents for corresponding pages.

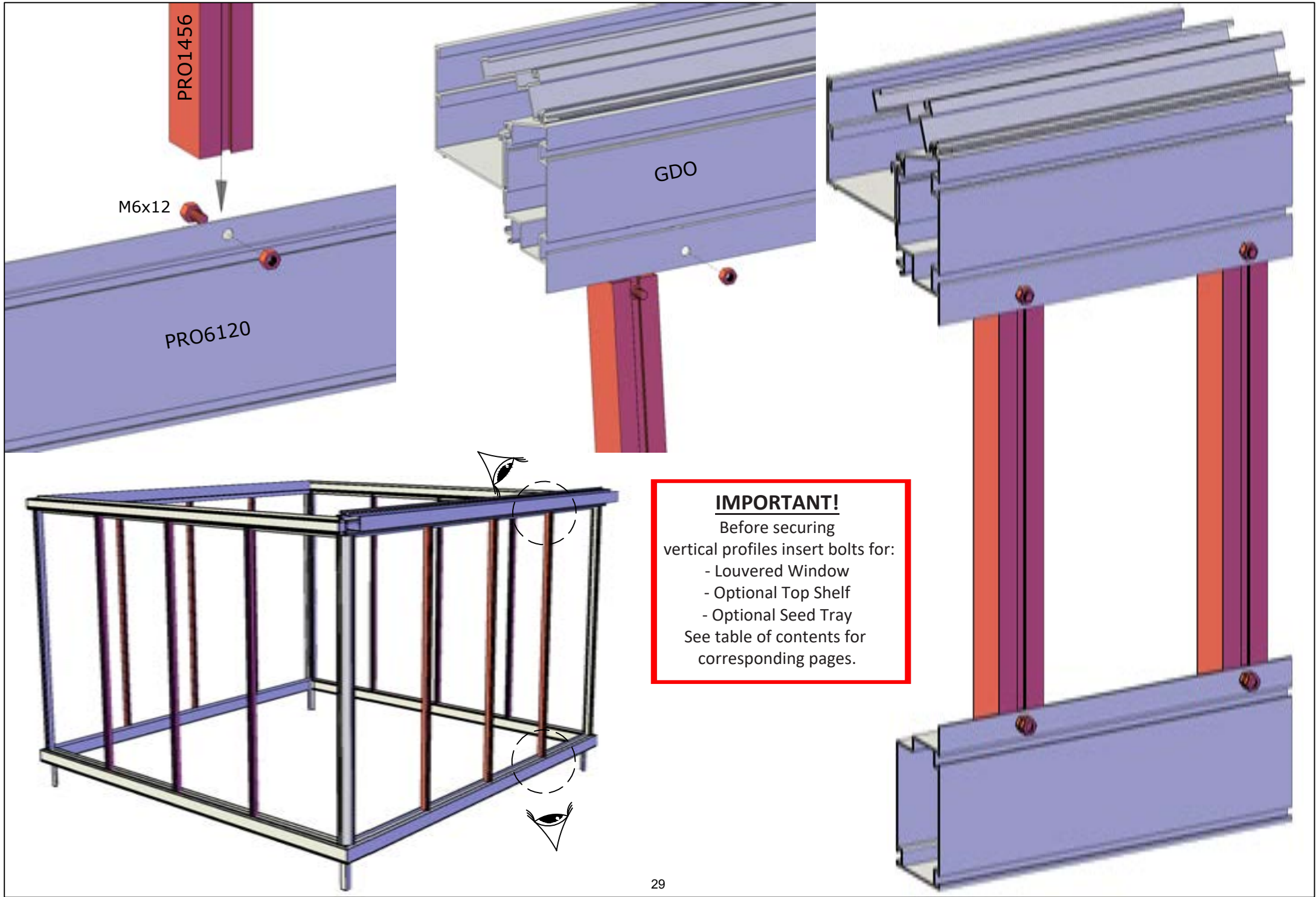

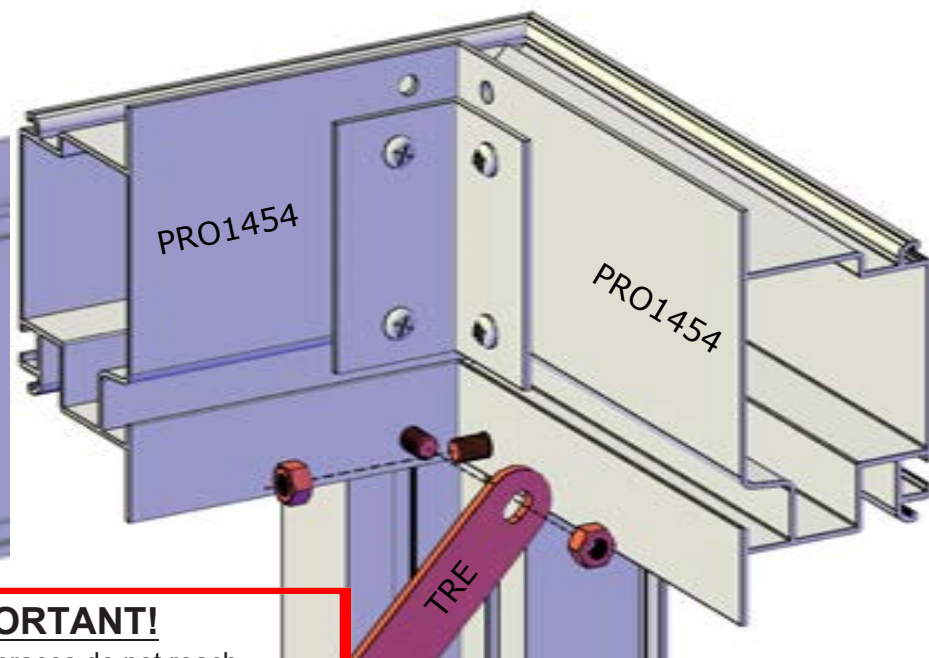
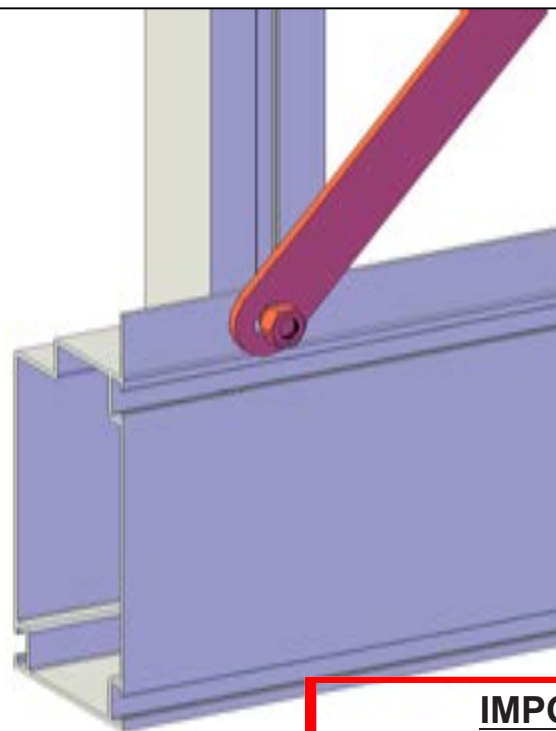
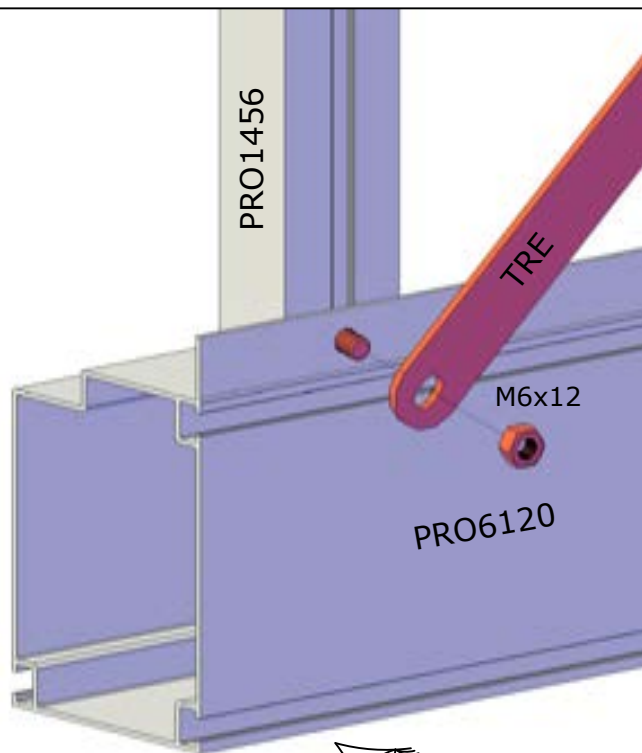

IMPORTANT!
If your wind braces do not reach your greenhouse is **NOT SQUARE**. Measure distance between diagonal corners - they should be equal. Use a level to determine where the issue lies and fix before proceeding.

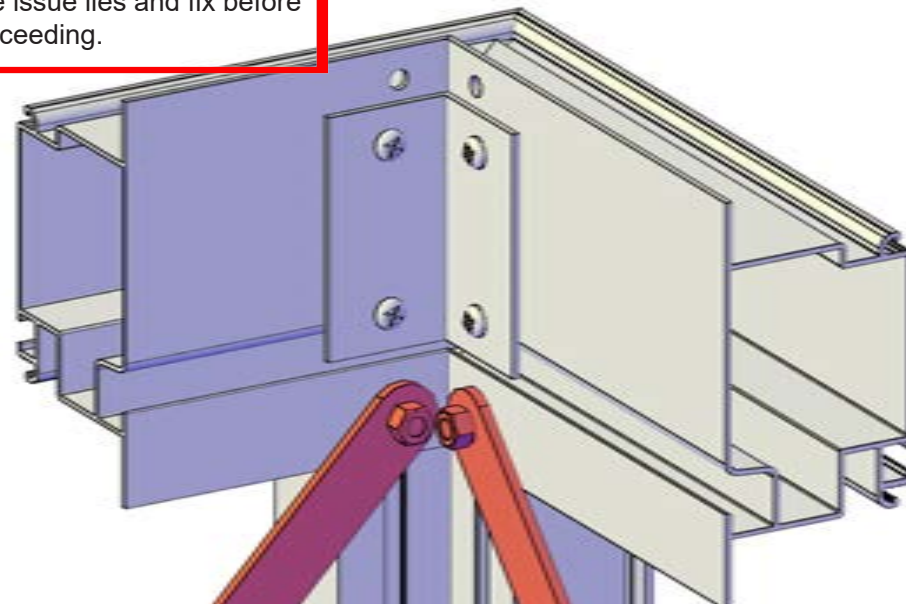
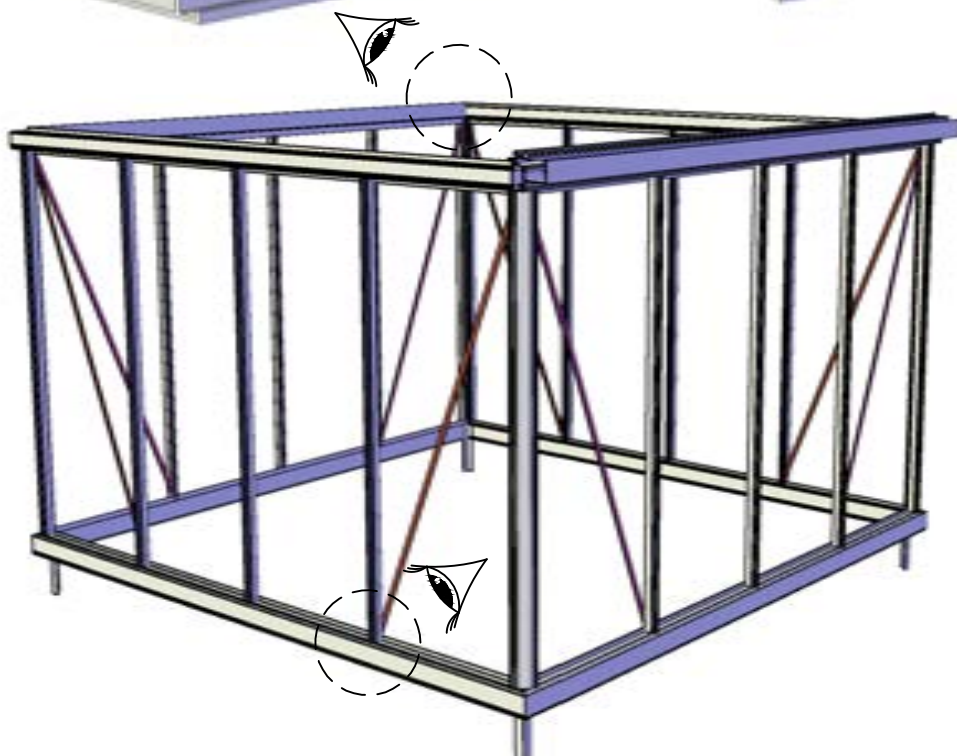

M6x12

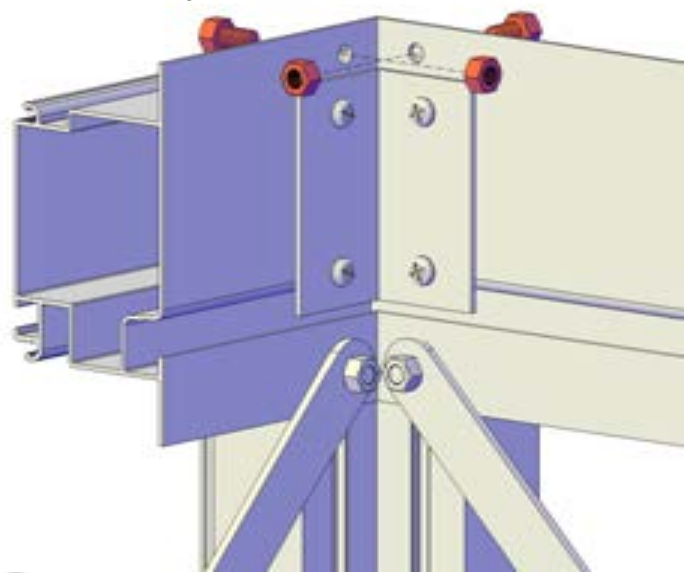

PRO6578

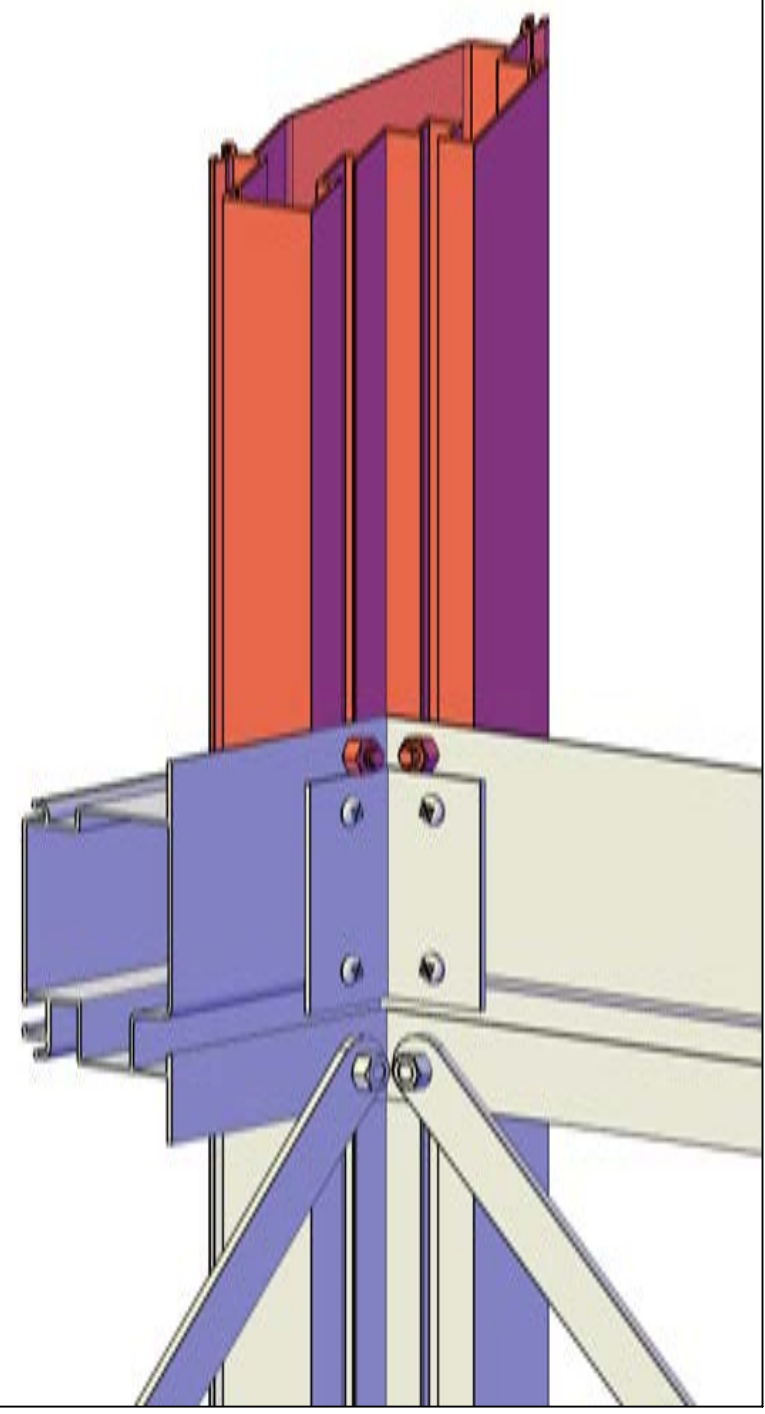
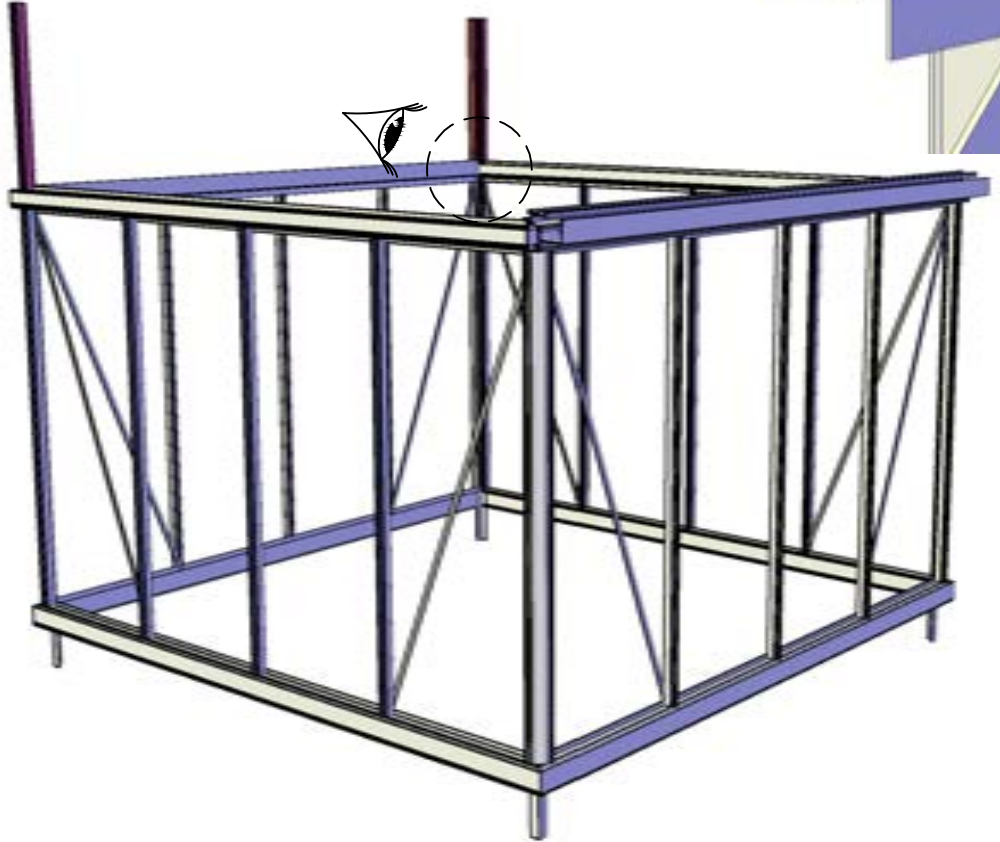
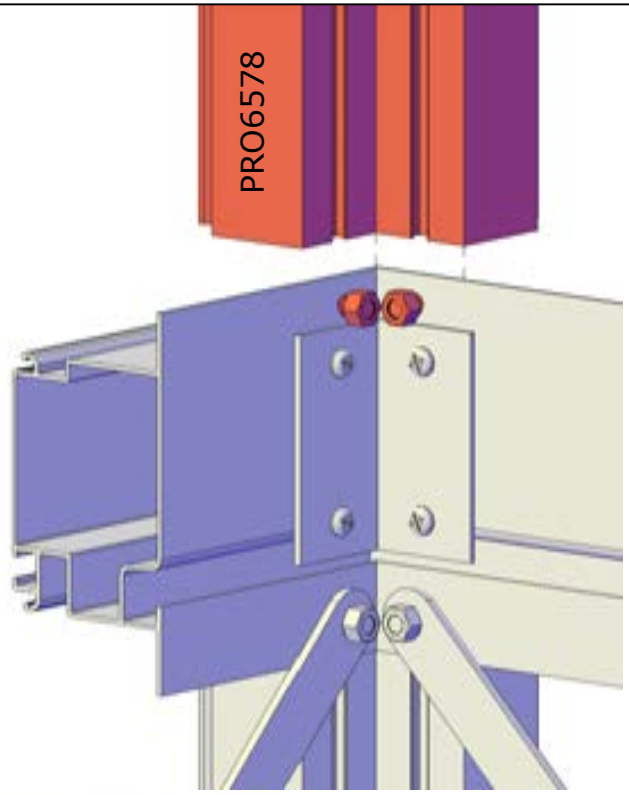

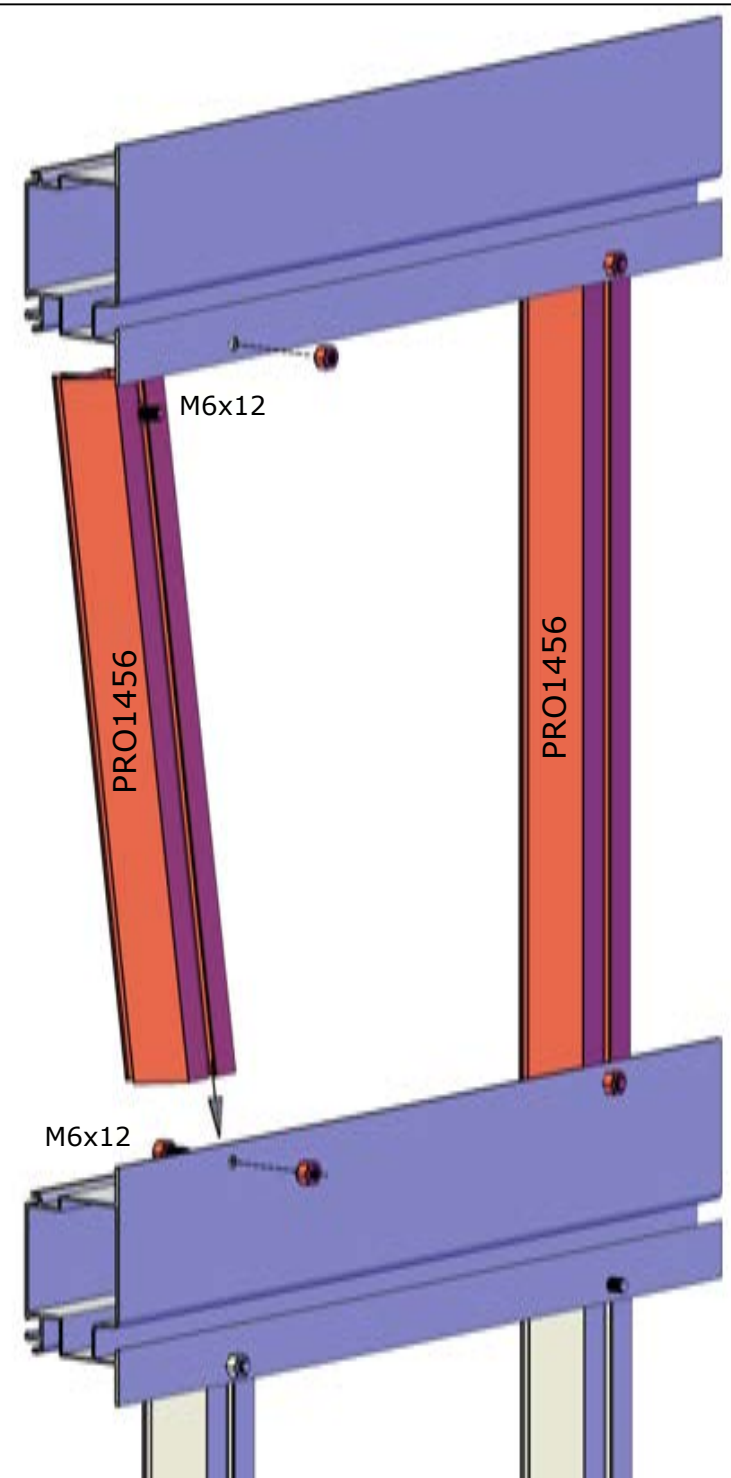
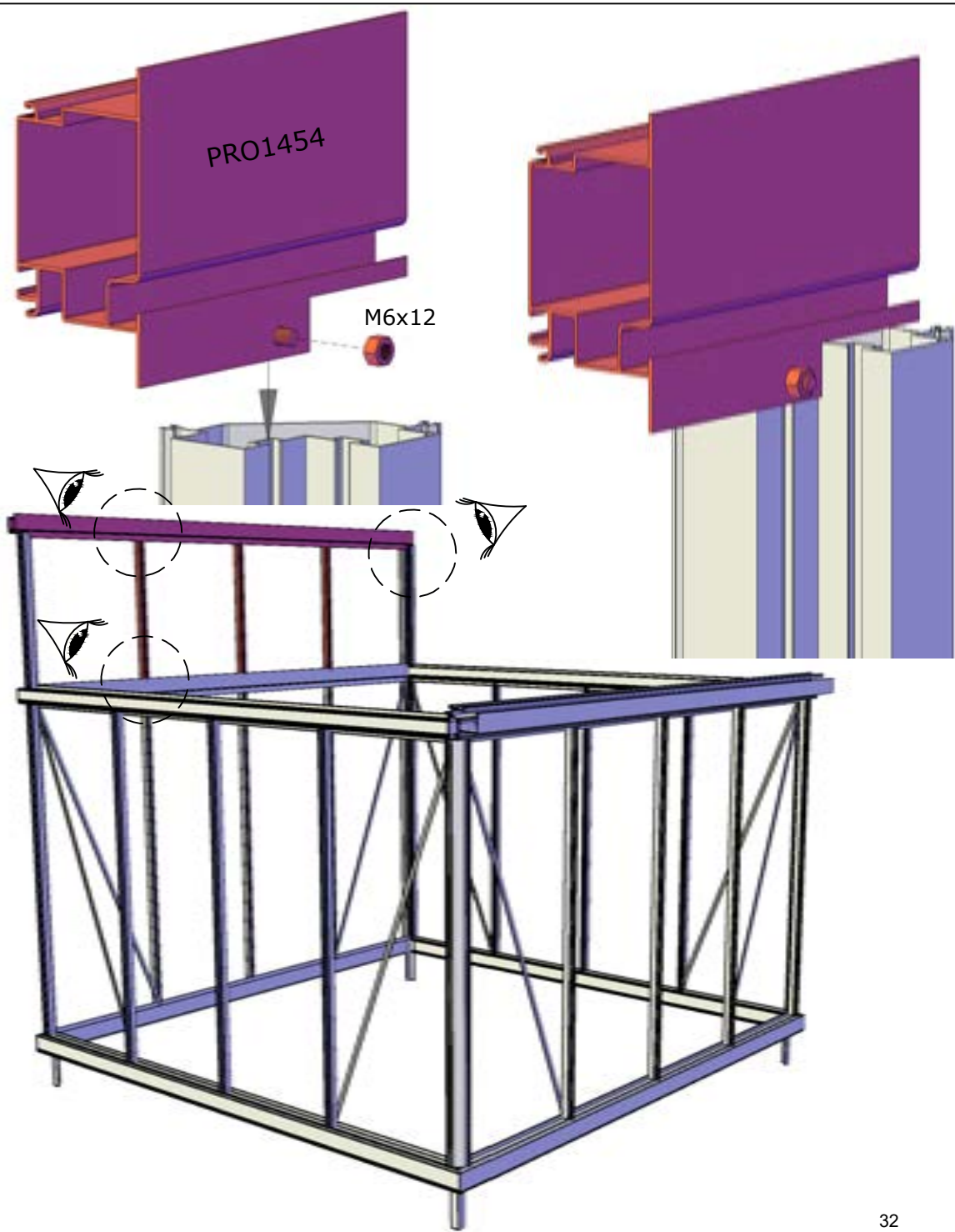

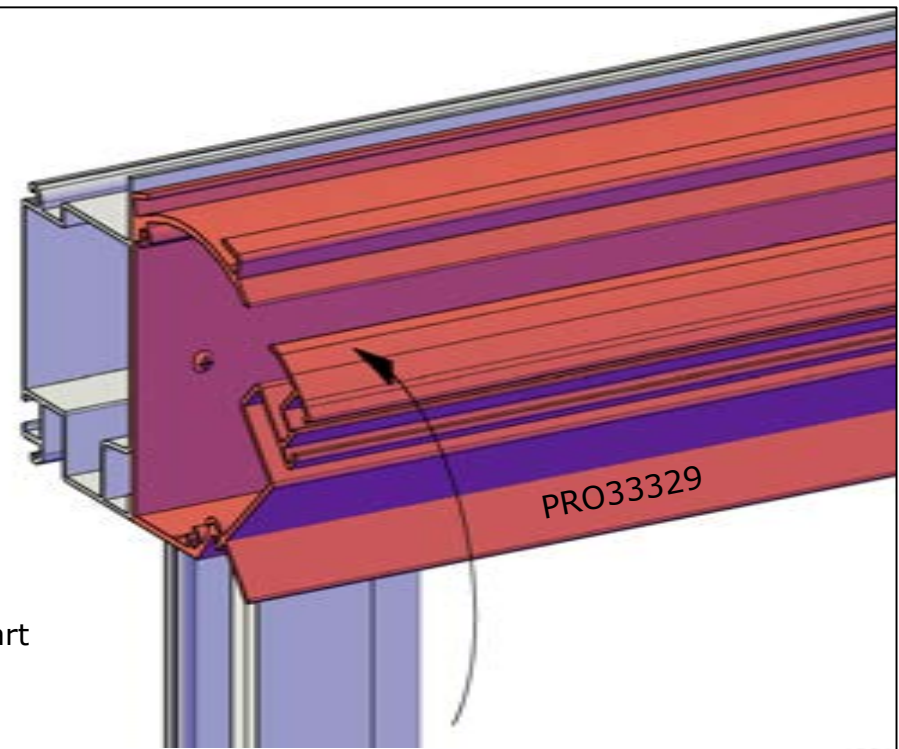
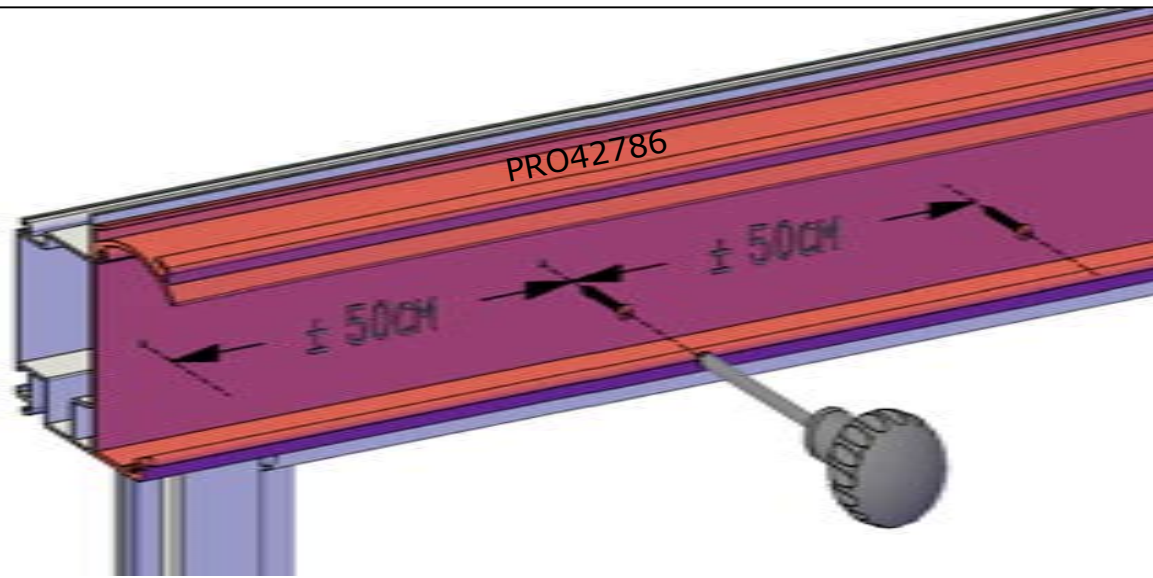

Pre-drill holes 50 cm (19 11/16") apart and attach screws to connect the PRO42786 to the PRO1454 profile.

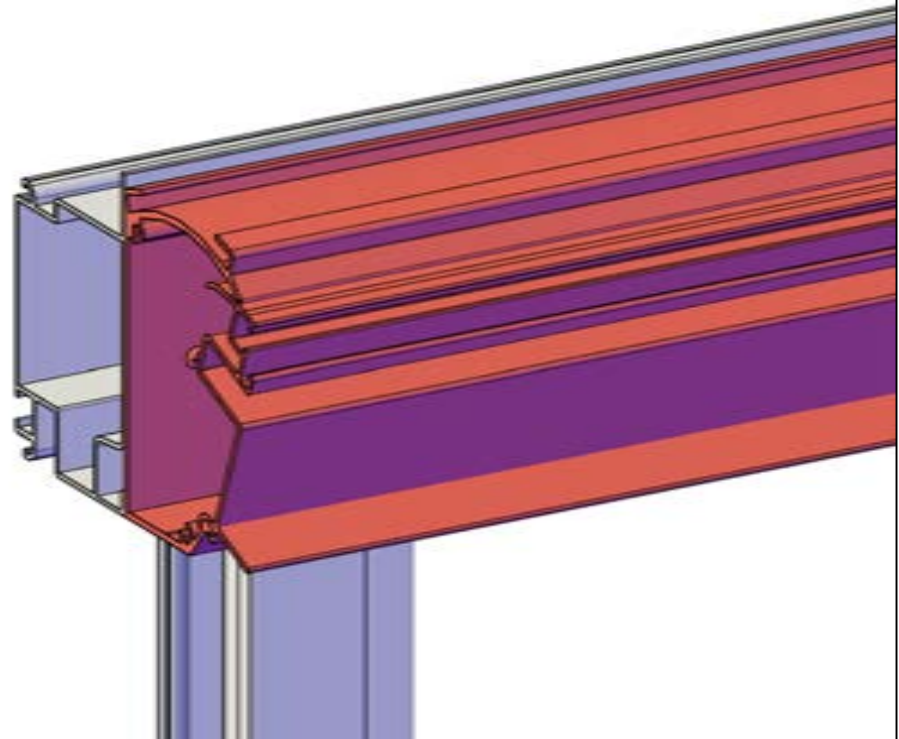

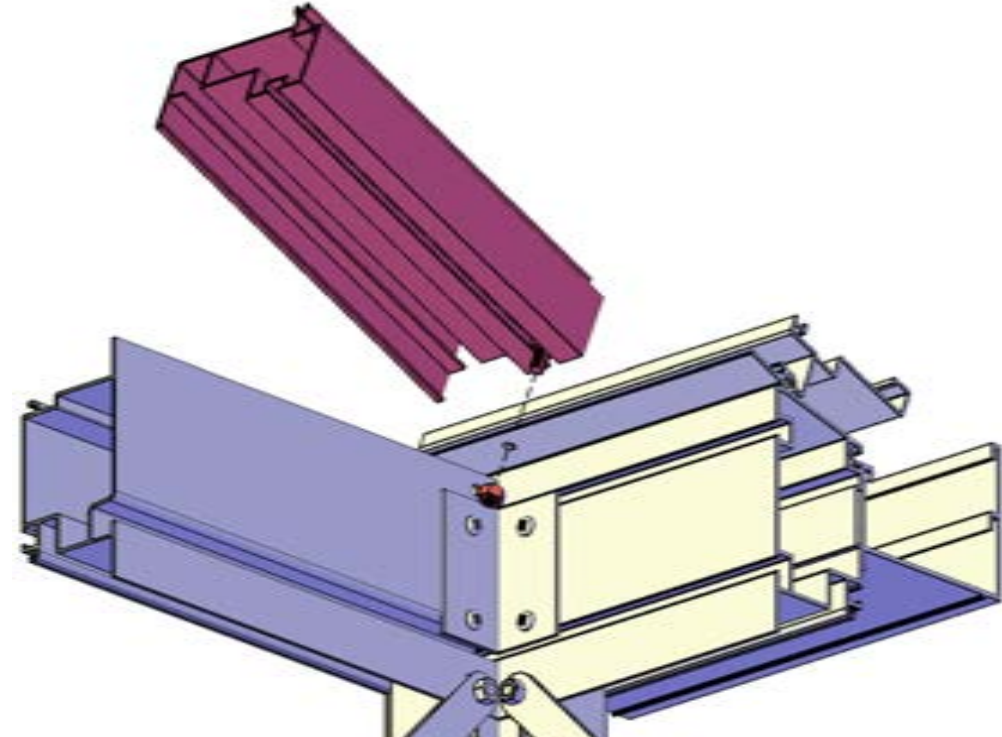
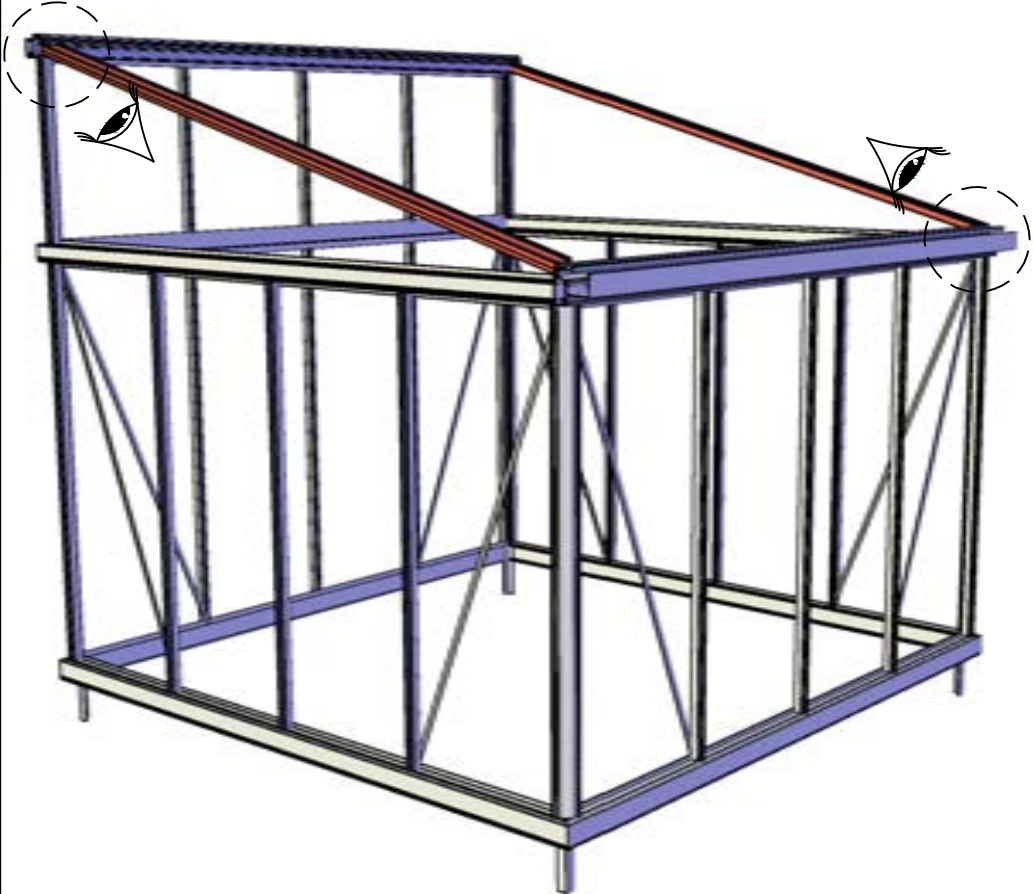
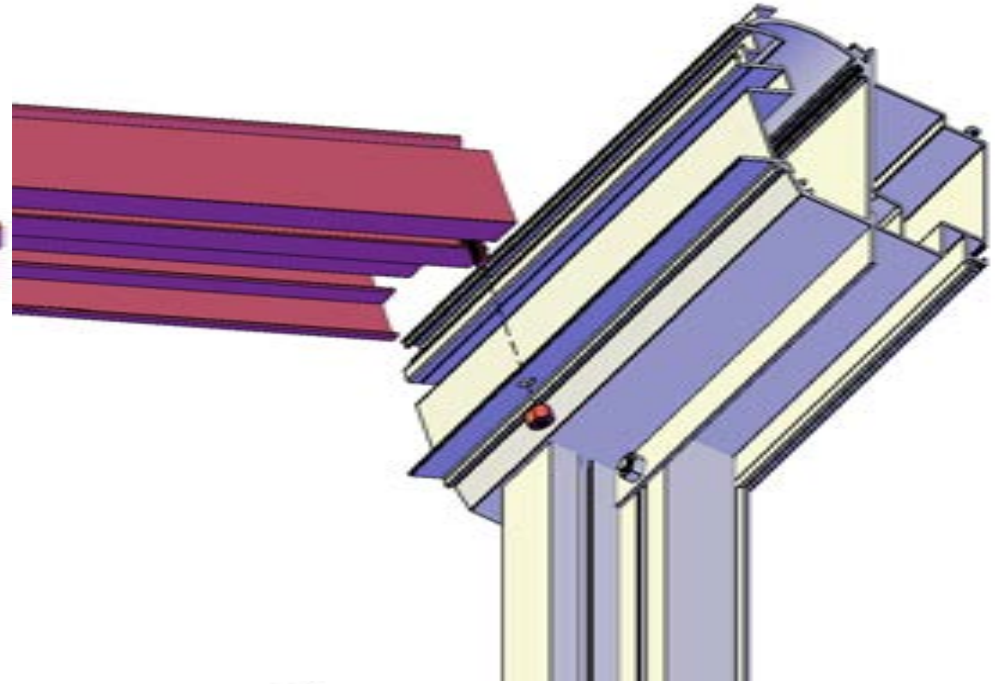
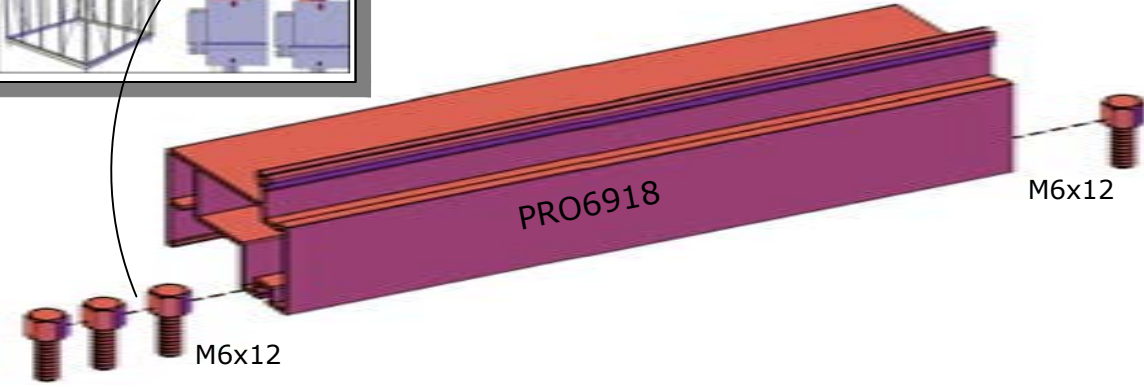
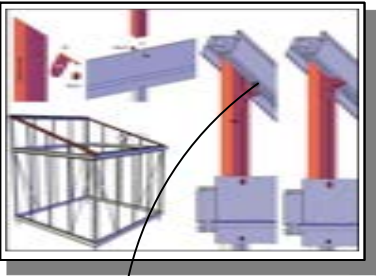

PRO1456

LG

M6x12

M6x12

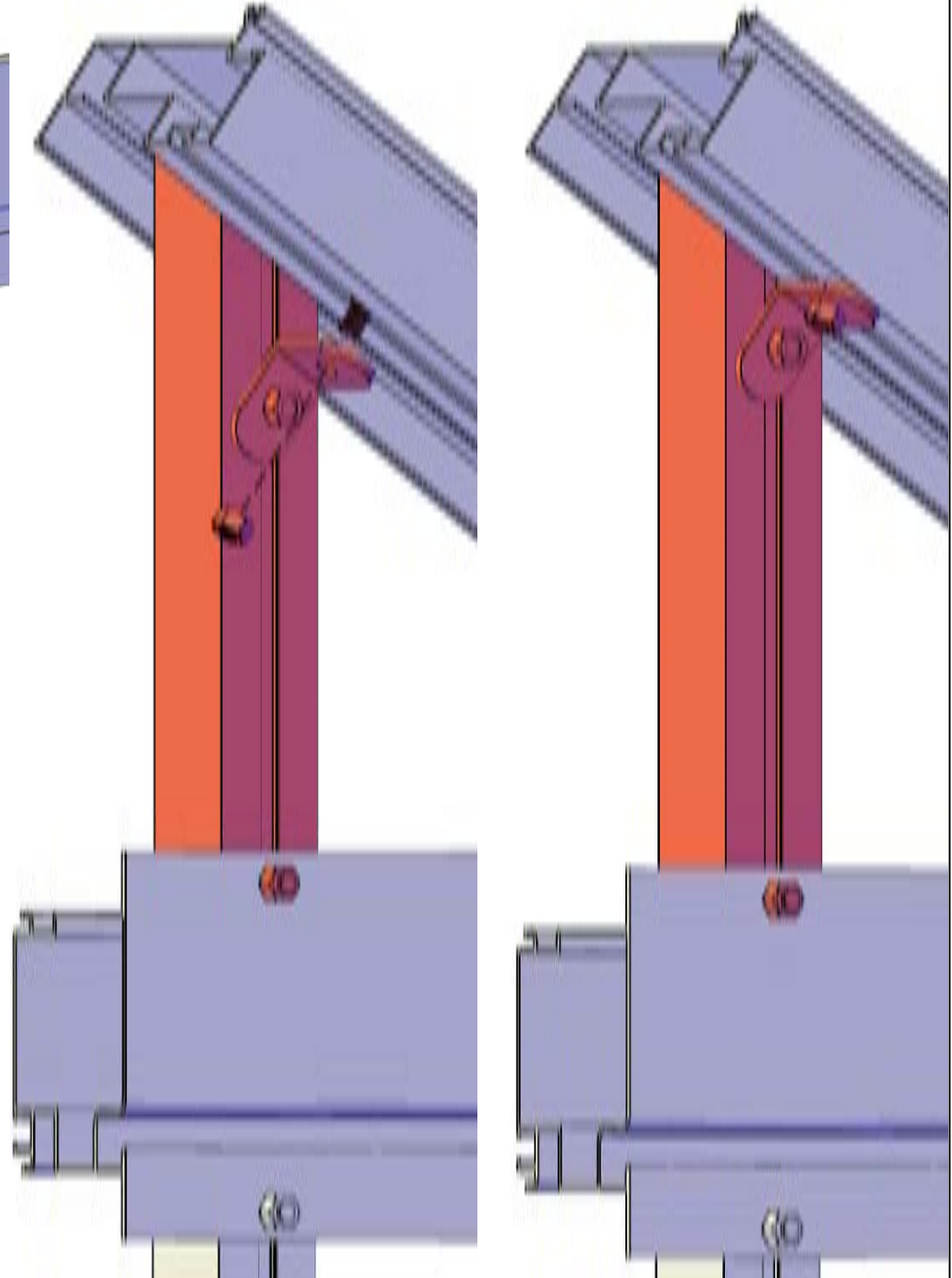
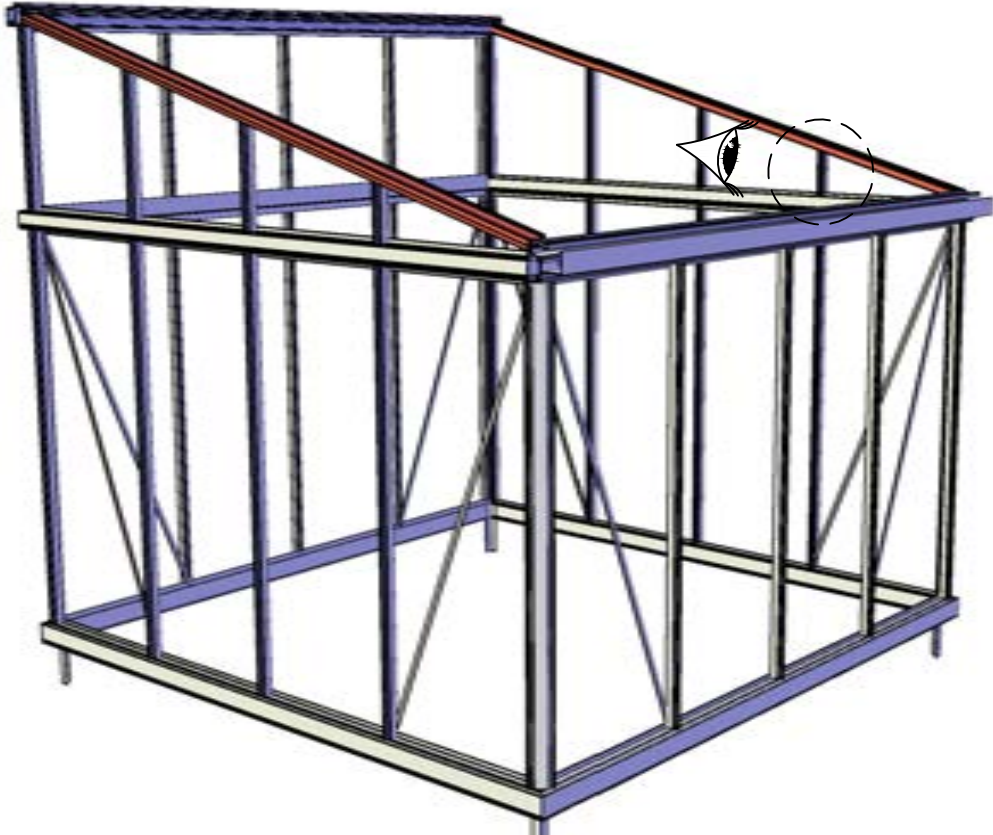

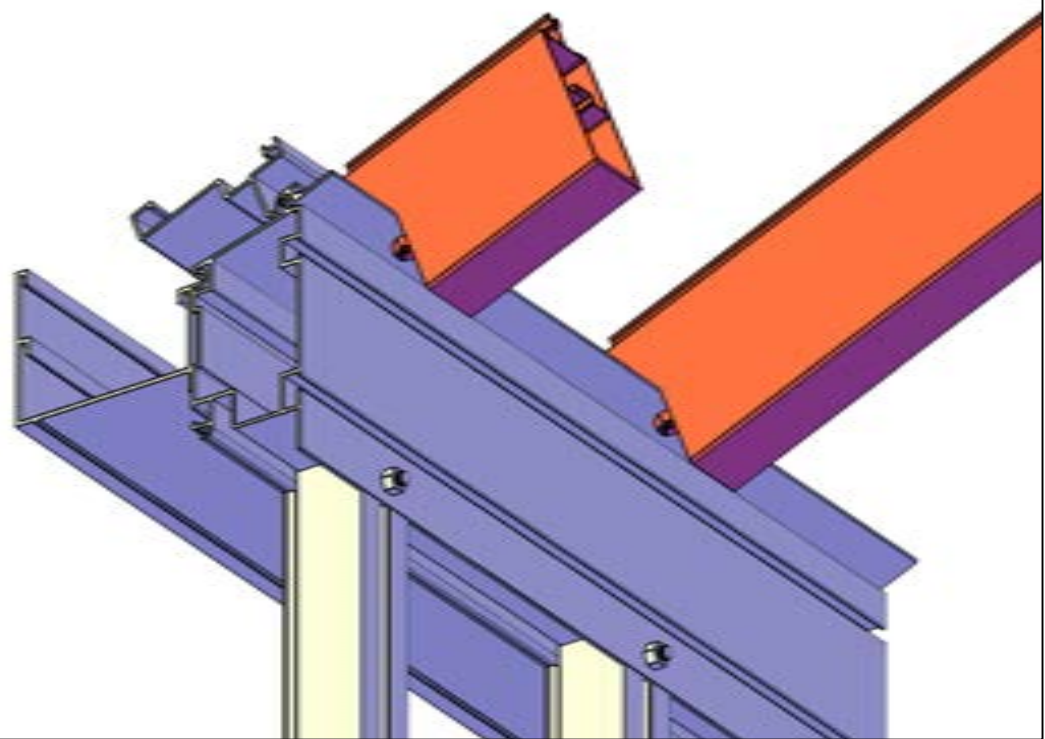
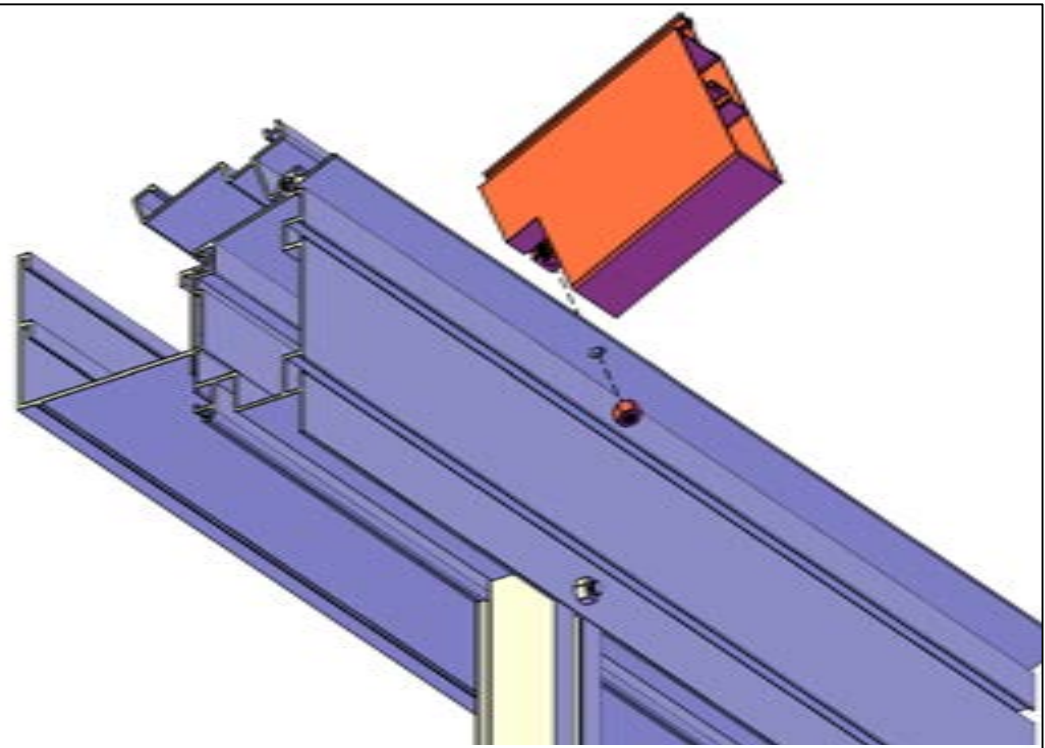
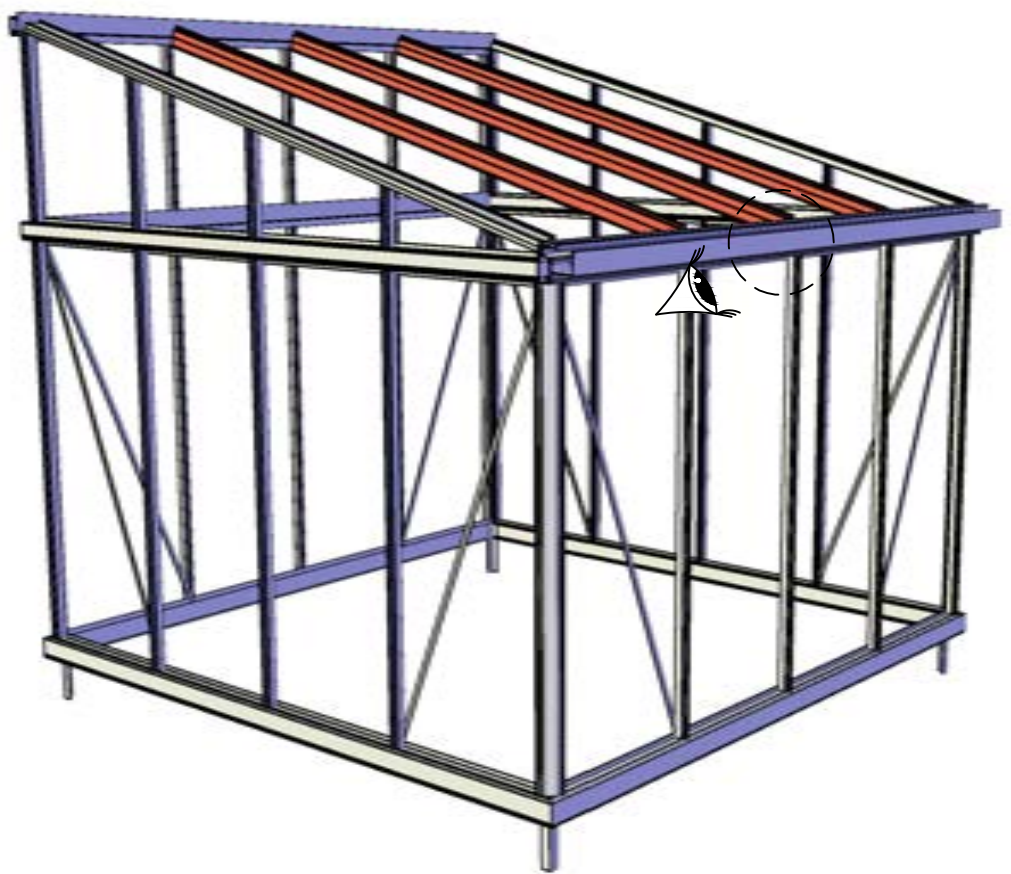

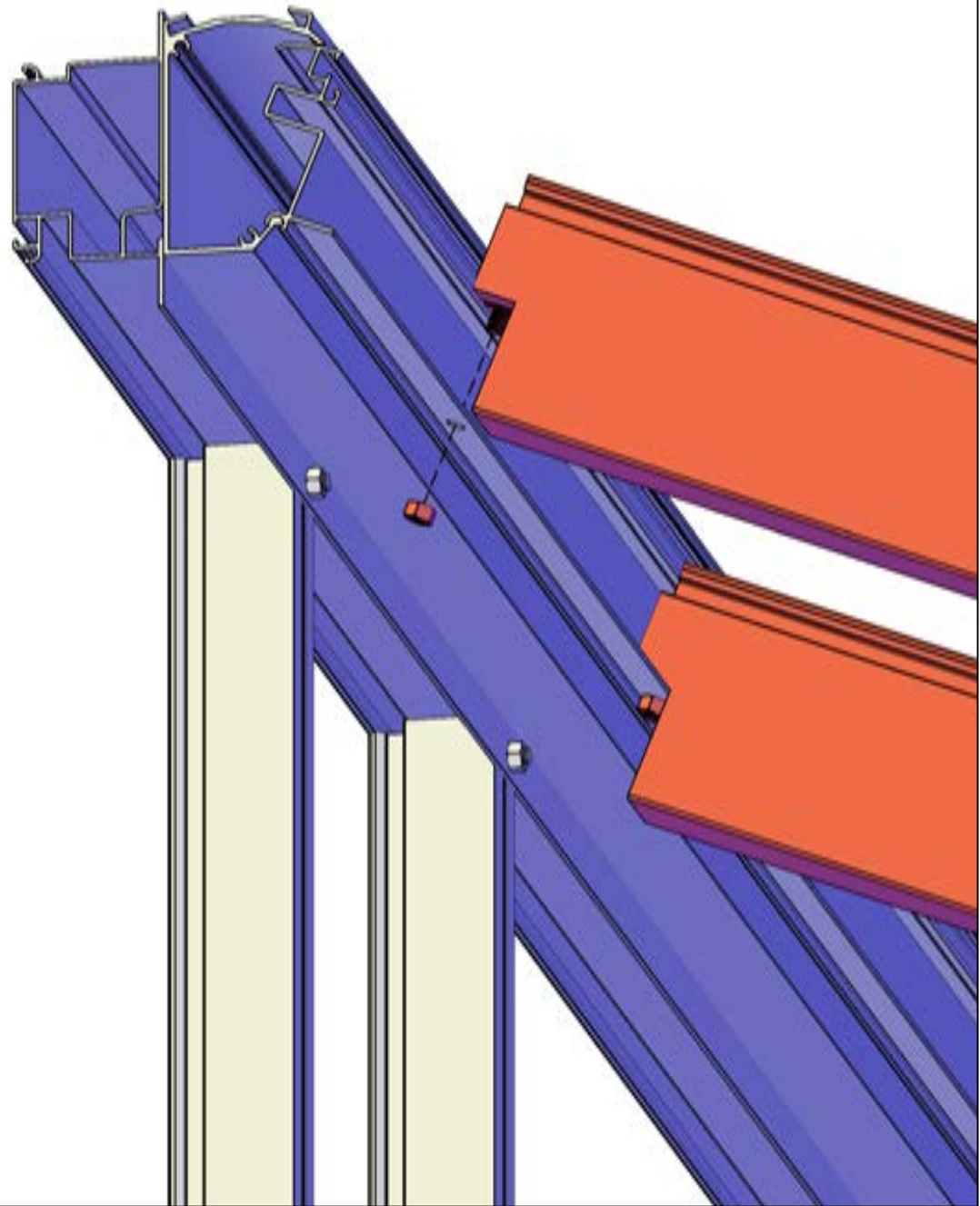
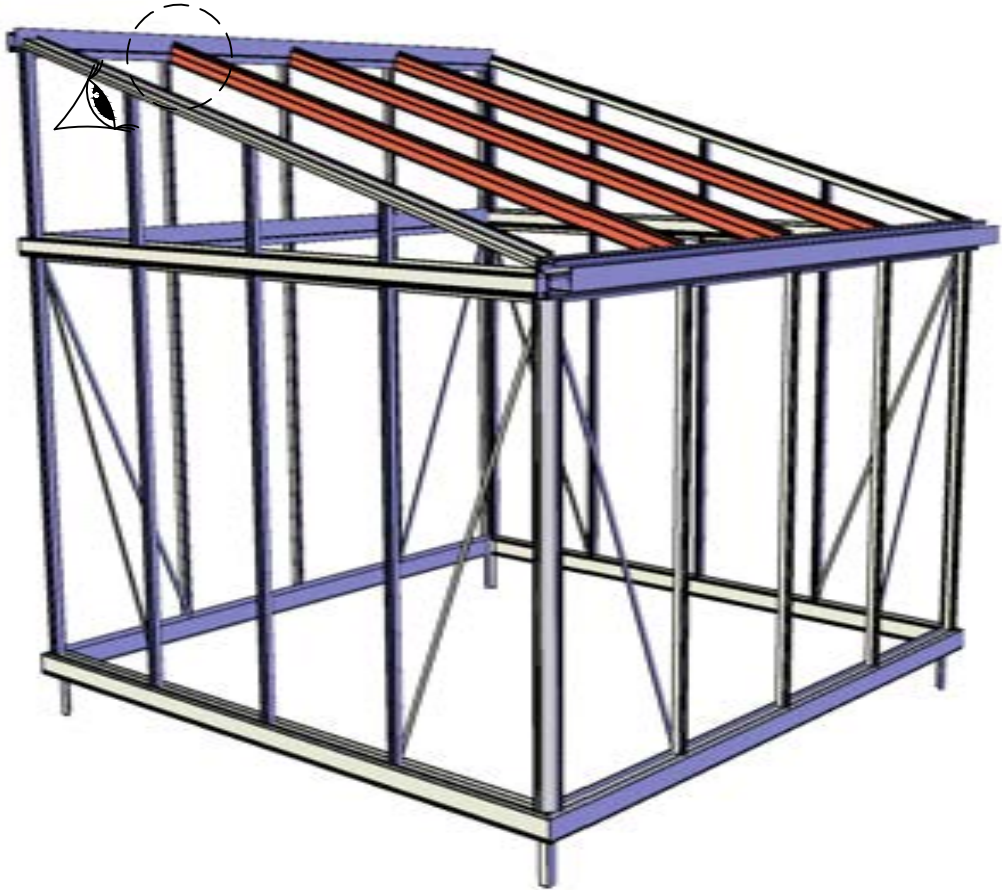

The Modern will come with a triangular reinforcement brace.
The M23 will come with (1) triangular reinforcement brace.
The M34 will have (2).
The M36 will have (3).

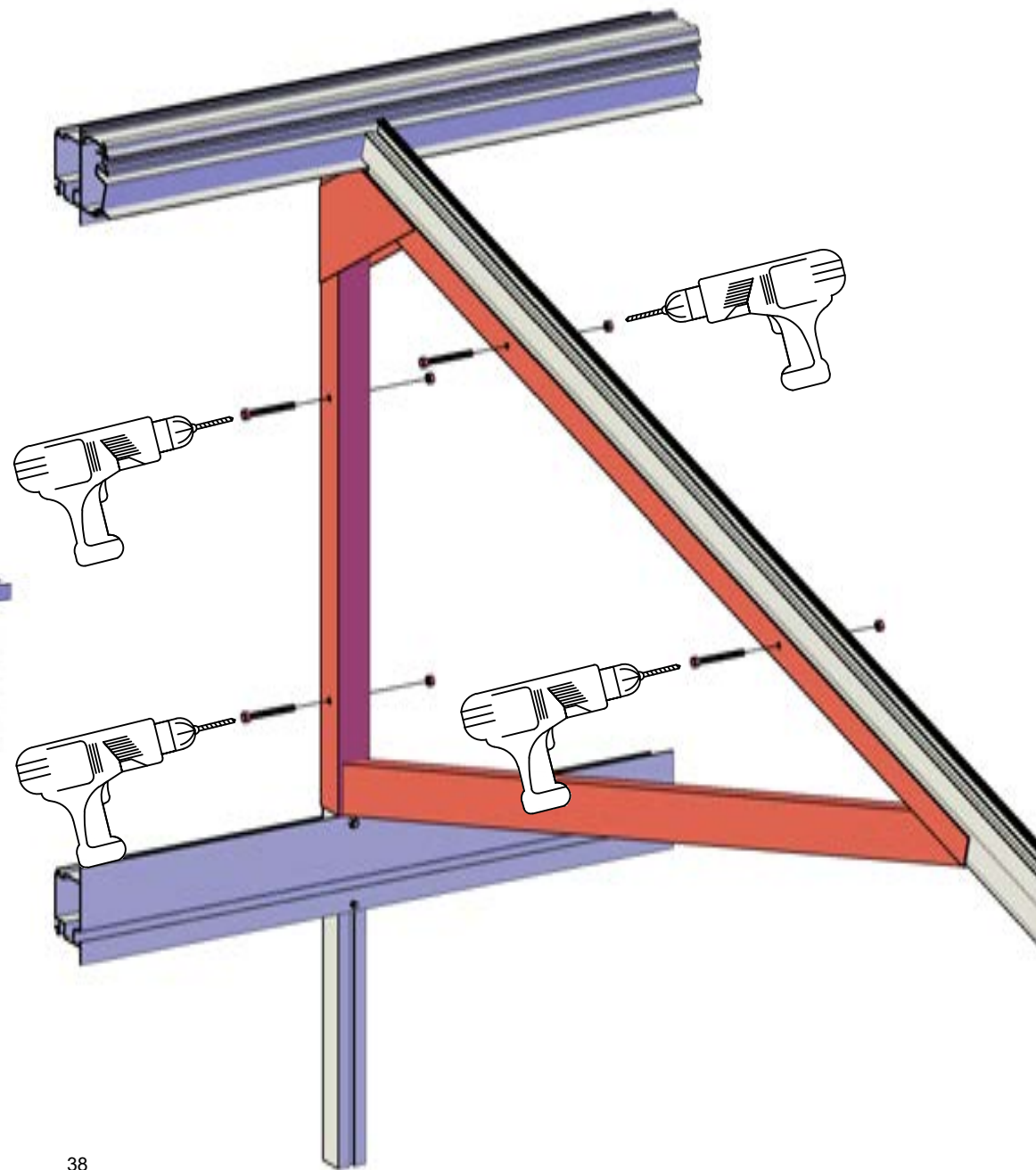
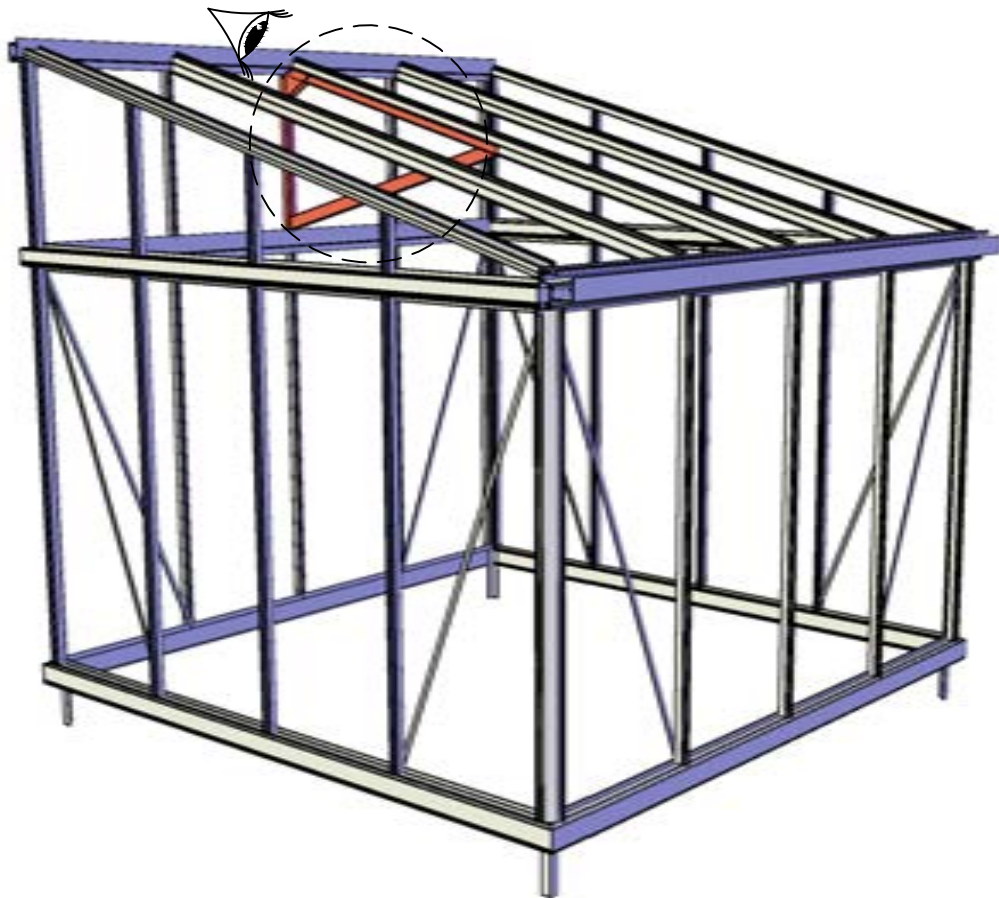

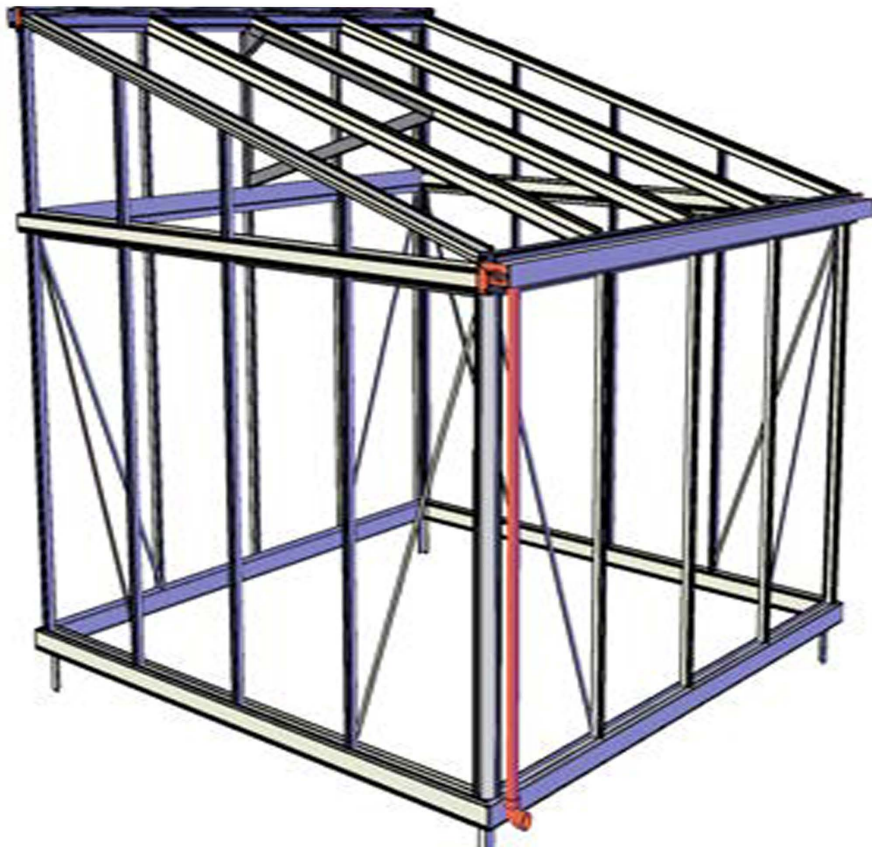

Attach the elbow to the greenhouse base. First, drill a small hole in the back of the elbow and then a small hole in the frame of the greenhouse for the screw to thread into. Run the screw through the hole on the inside of the elbow and into the greenhouse base.

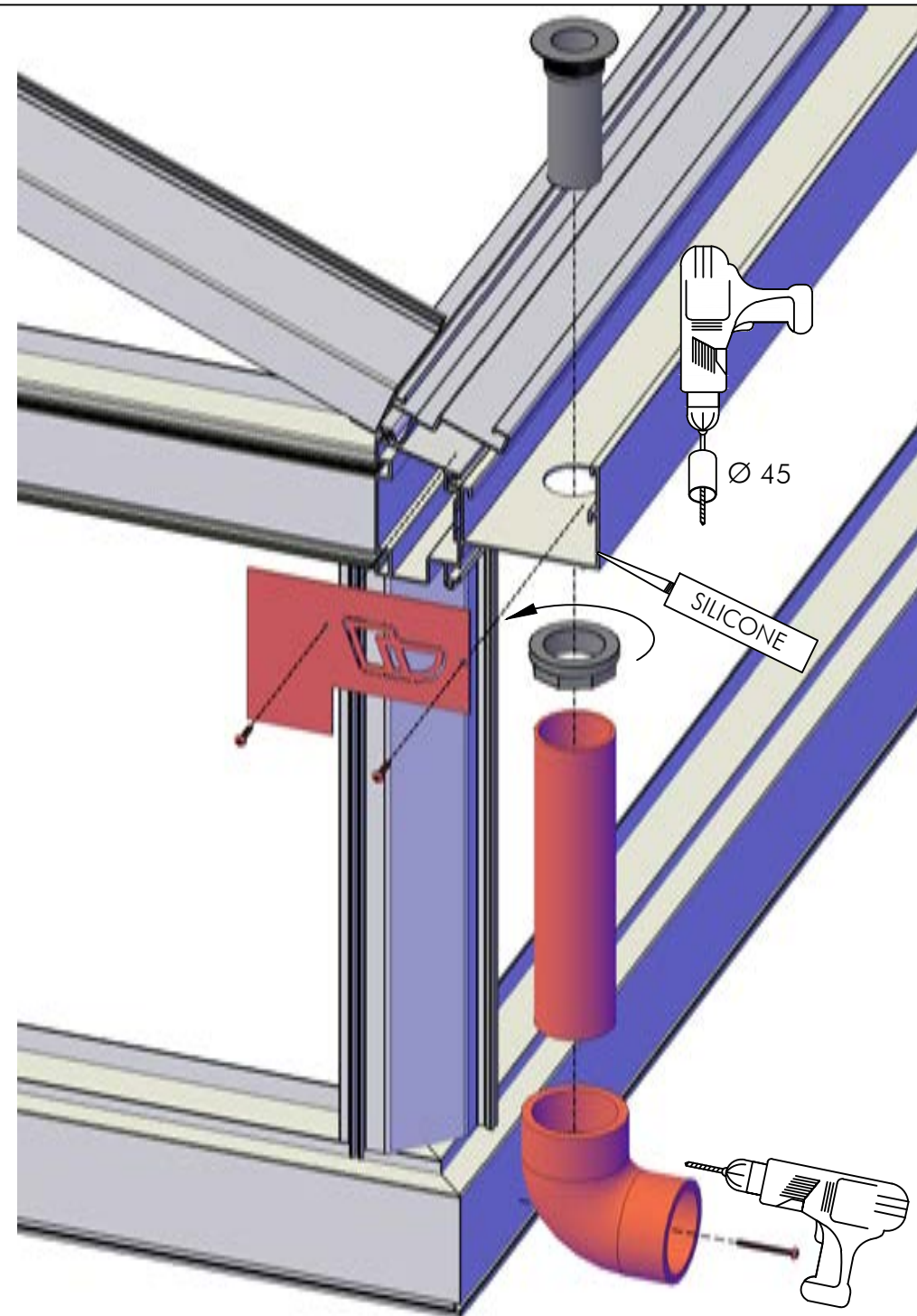

Install the crossbar for the roof windows
790mm (31 1/8") from the edge of the
roof rafter

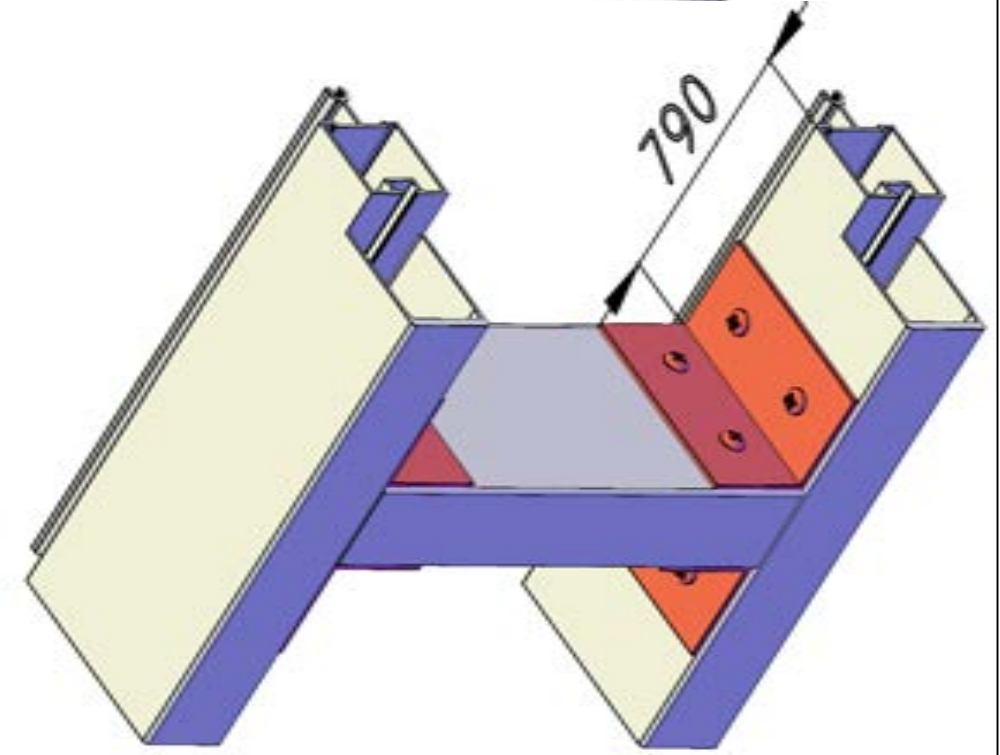
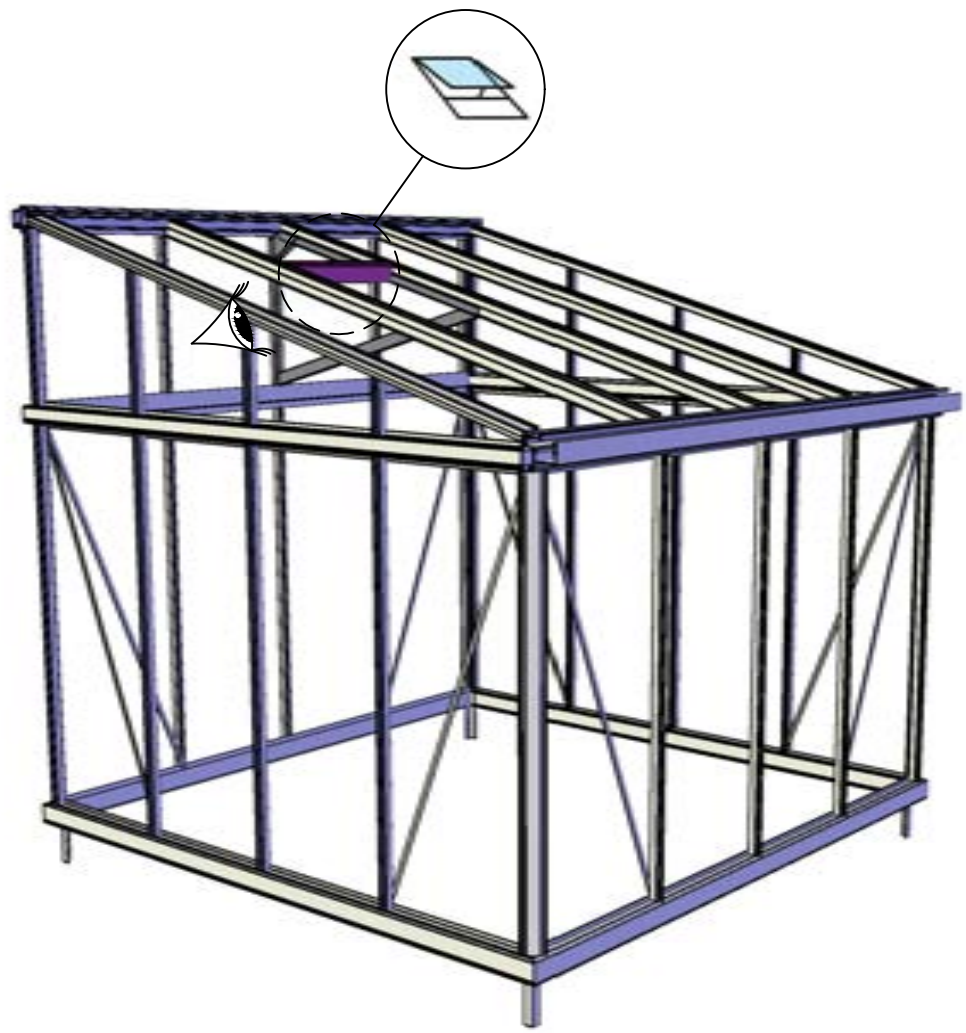
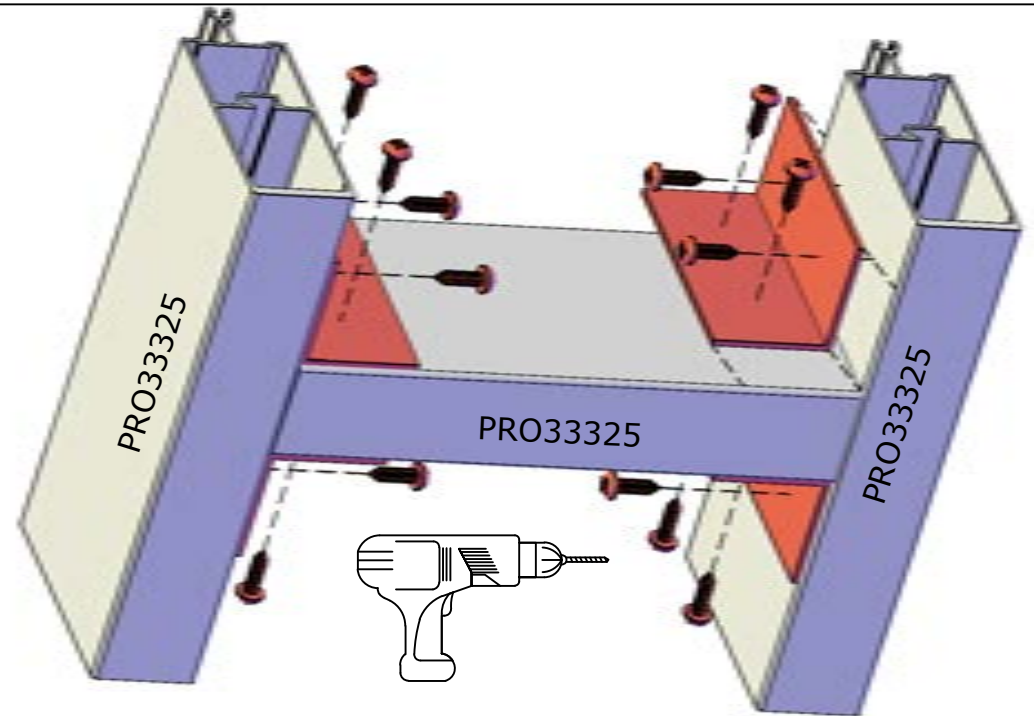

Installation of Roof Glass for Modern 34 (10'2" x 15') & 36 (10'2" x 19'11")

The roof glass for the Modern 34 & 36 greenhouse will have (2) panes overlapped for each of the roof bays. This will NOT apply to the Modern 23 (7'9" x 10'2"). Please follow the steps below on how to install. For safe and proper mounting, we recommend (2) people, (2) ladders, tape, and pliers to bend the clip.

Long Roof section:

Lower (larger) Roof pane 1 => 1715 mm long (67 1/2")

Upper (smaller) Roof pane 2 => 1450 mm long (57 1/16") There will be about 40 mm (1 9/16") overlap

Glass Roof Window => 730 x 825 mm (28 3/4" x 32 1/2")

Glass Under Roof Window:

Lower (larger) under Roof Window => 1715 mm (28 3/4" x 67 1/2")

Upper (smaller) under Roof Window => 625 mm (28 3/4" x 24 5/8")

There will be about 40 mm (1 9/16") overlap

There will be one silver clip included for each bay.



Step 1: Position (1) person working above the greenhouse and (1) person working on the interior, you will need two ladders. Place the bottom/larger glass in position first - inserted in the channel above the gutter.

Step 2: The top person should place the upper/small glass pane into position on the top portion into the ridge beam channel. While holding the glass in position, the top person should slide the silver clip onto the bottom edge of the top pane, as shown below. *(Tip: it may be helpful to temporarily tape the clip in place before putting the glass on the roof.)*

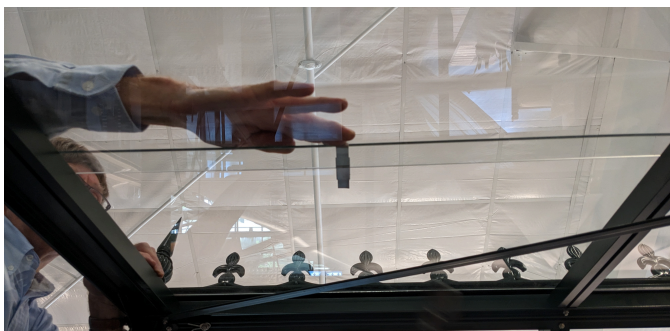
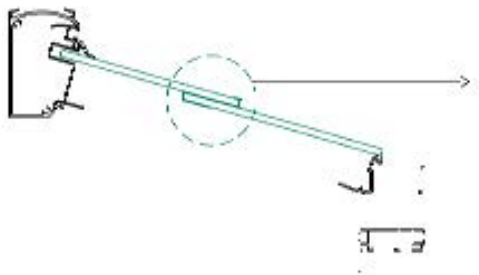

Step 3: While the top person is holding the upper glass (and clip) in place, the interior person will bend the clip around the bottom pane of glass with pliers as shown below. The remainder can be secured and pushed with a thumb.

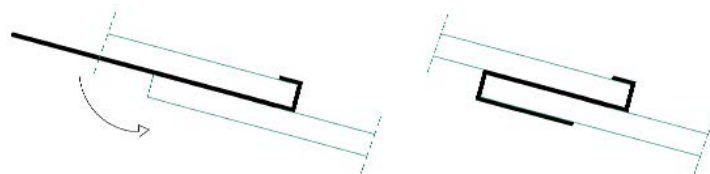

Step 4: It is recommended to use a bead of clear silicone on the interior seam between the glass panes once the glass is in place. If desired, you may add another on the exterior, although it should not be necessary.

Glazing shim installation:
 install the glass panels then fix the sims to either side of the glass with a dab of silicone. Then, install the rubber trim. Shims are only installed in end panels as shown below. Space the shims 100mm (4") from the top and bottom. Polycarbonate units will not use these shims.

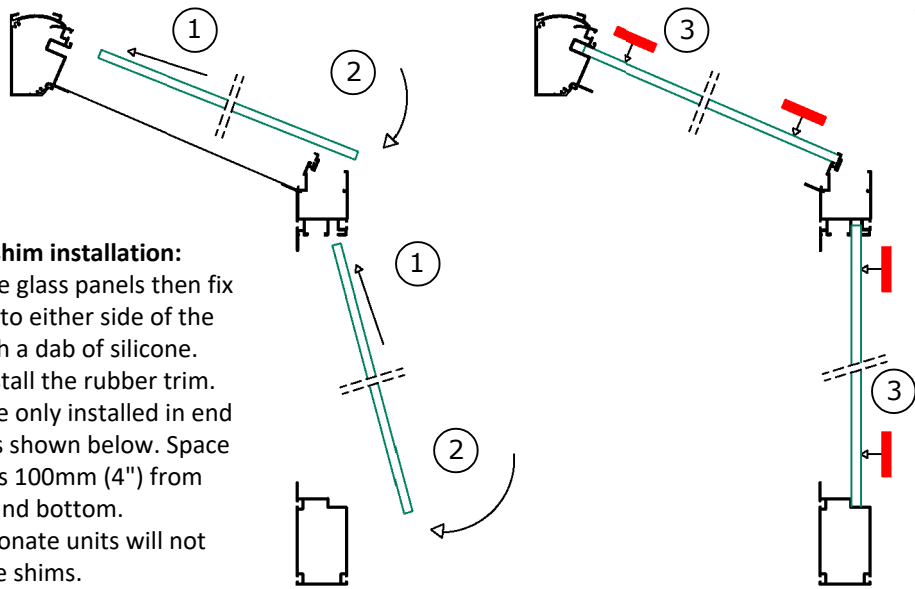

To install the gasket, roll it back on itself as shown below. This exposes the inner flange that is pushed into the channel. It will be easier to insert when warm and pliable.

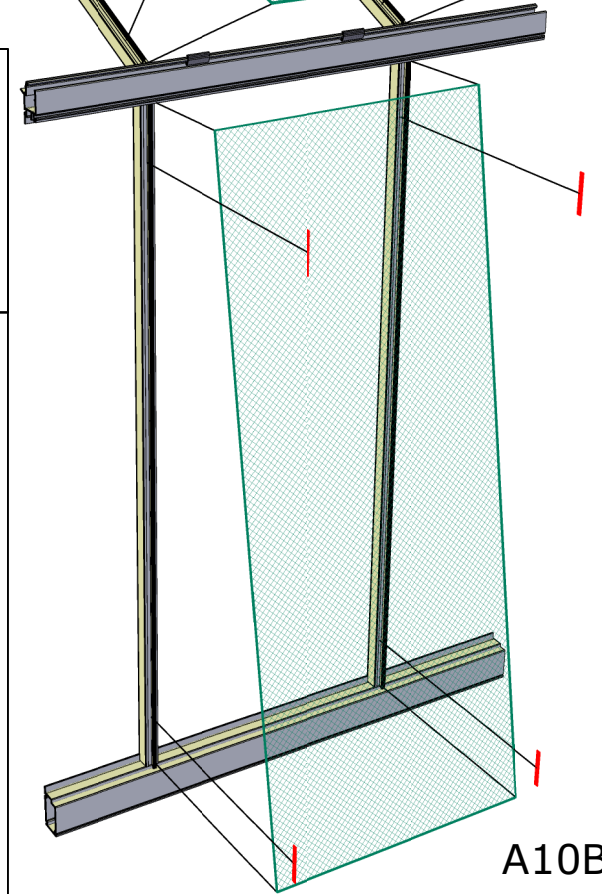
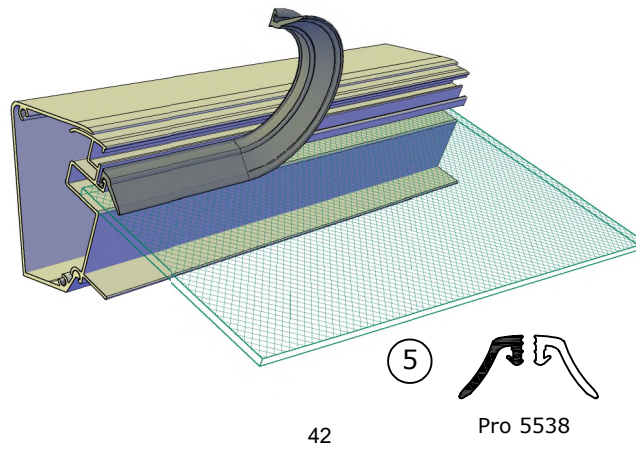
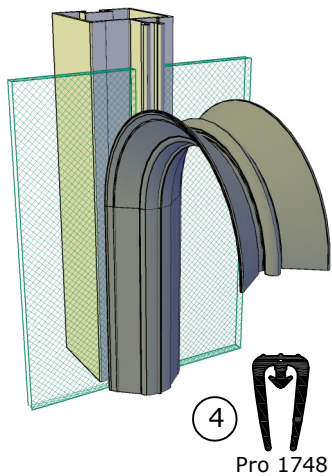
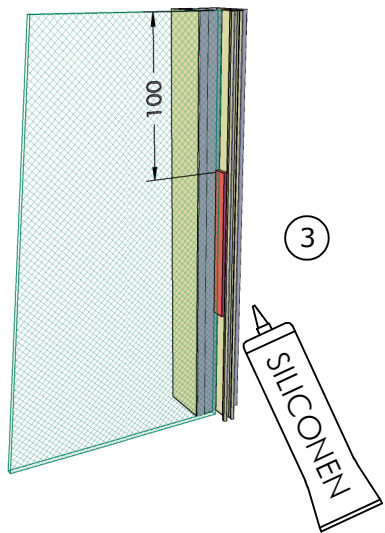
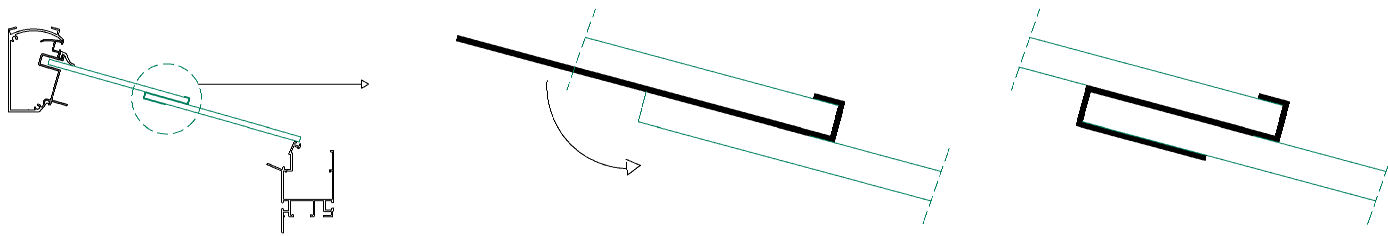
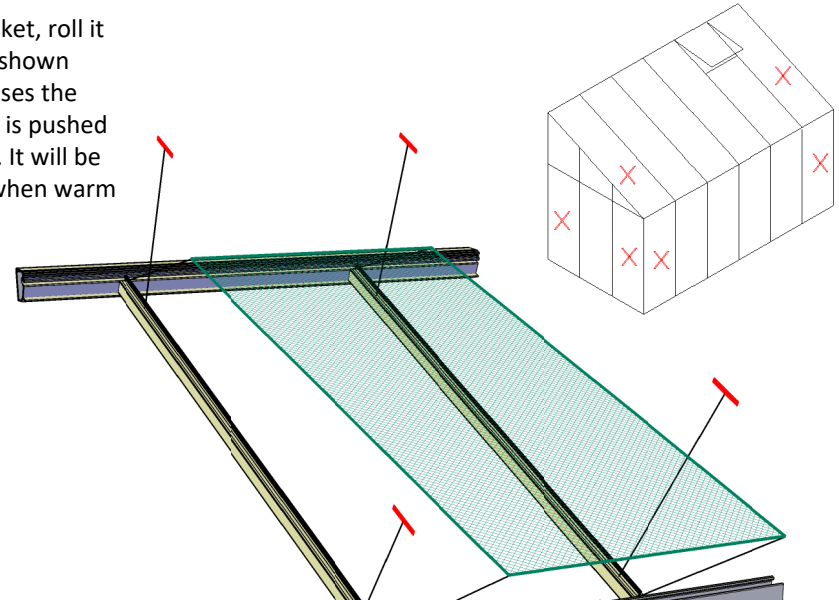

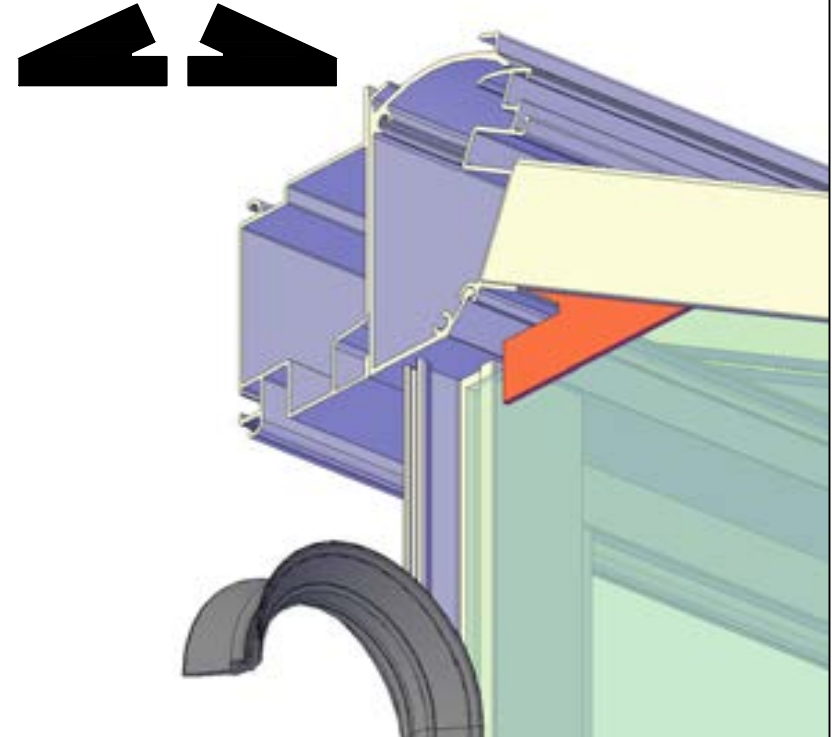
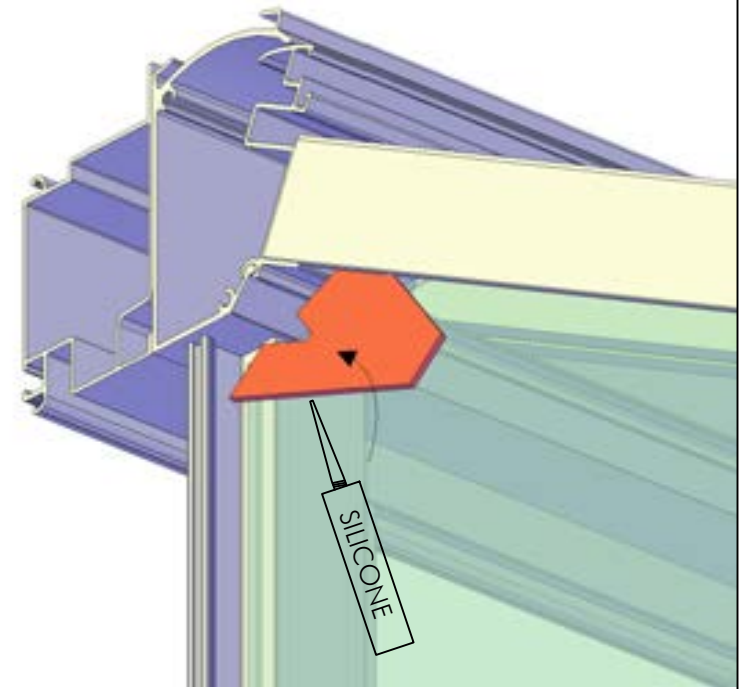
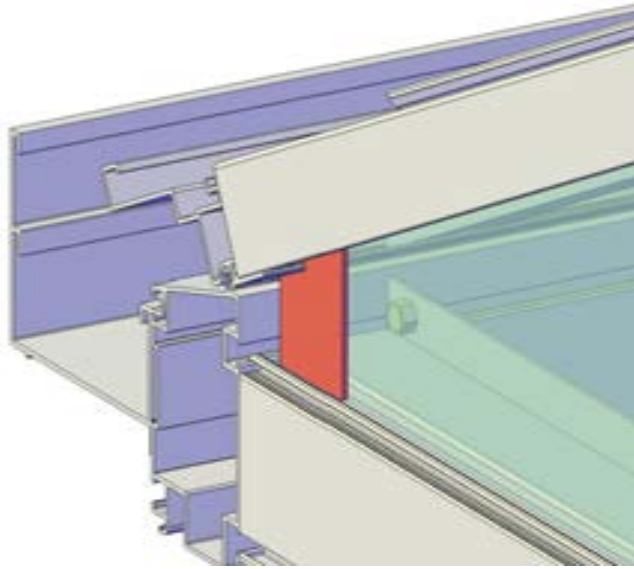
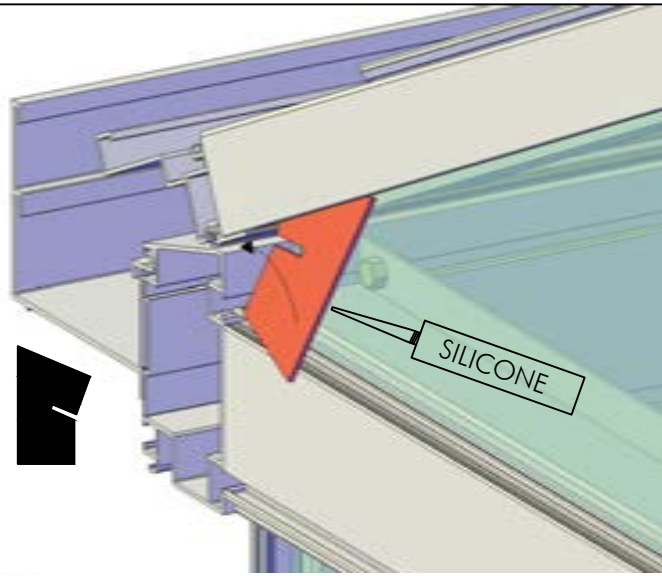



Crescent seal is only installed in the eaves and roof.

Not along side walls.



E400330

Crescent shaped rubber gasket (E400330) is NOT used with polycarbonate.

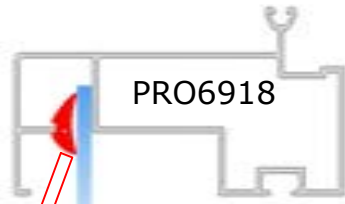

PRO6918

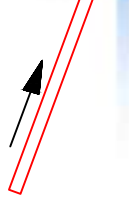

It helps to use a tool to push the gasket up under the eaves. Note that it inserts under the second flange further up.

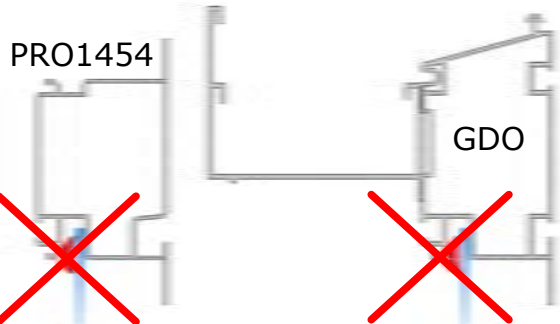
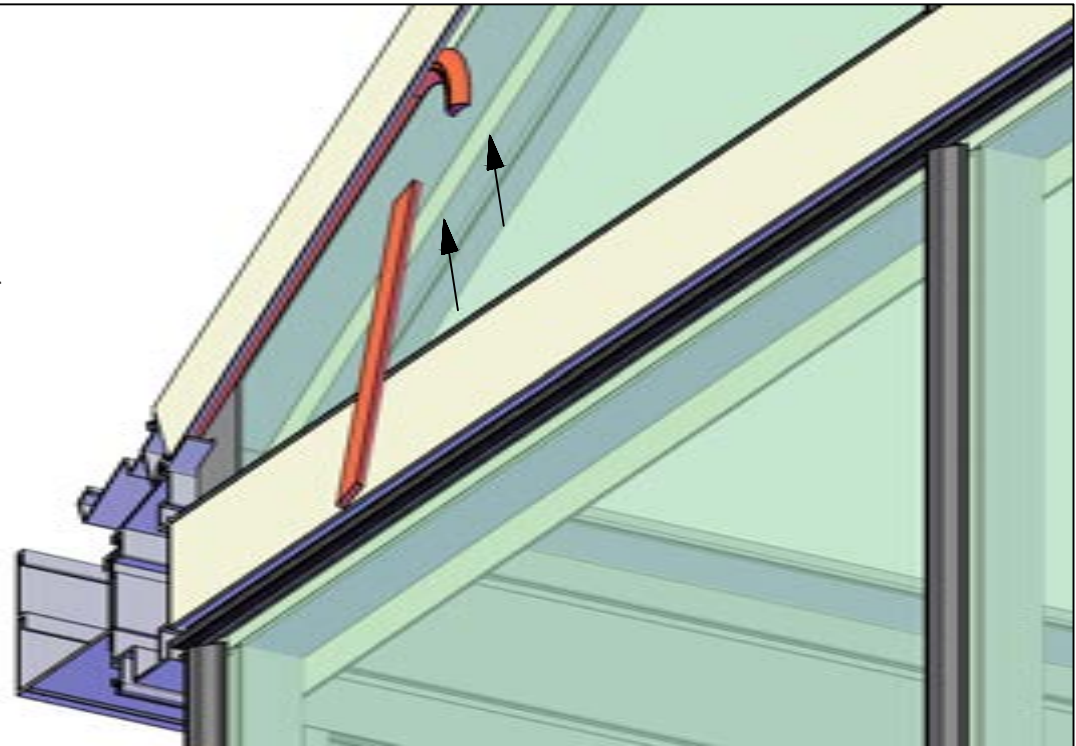
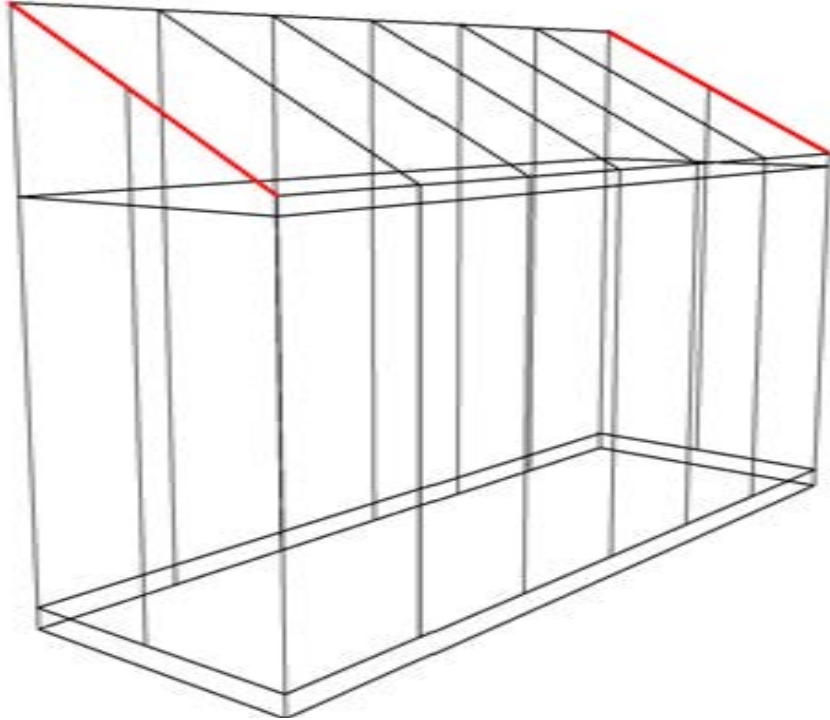

PRO1454

GDO

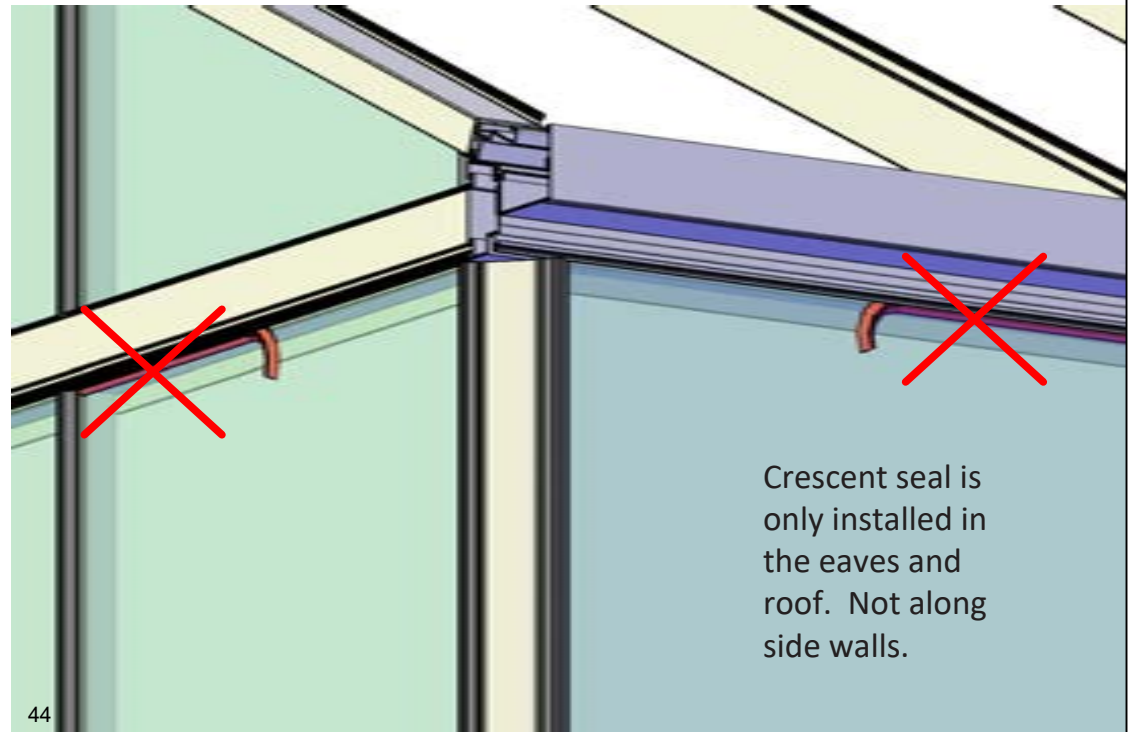

Crescent seal is only installed in the eaves and roof. Not along side walls.

To install heavy gasket, it is easiest to roll it back on itself as shown. This exposes the inner flange that is pushed into the channel. It will be easier to insert when warm and pliable. Install the roof glazing pane by pane, inserting gaskets after each.

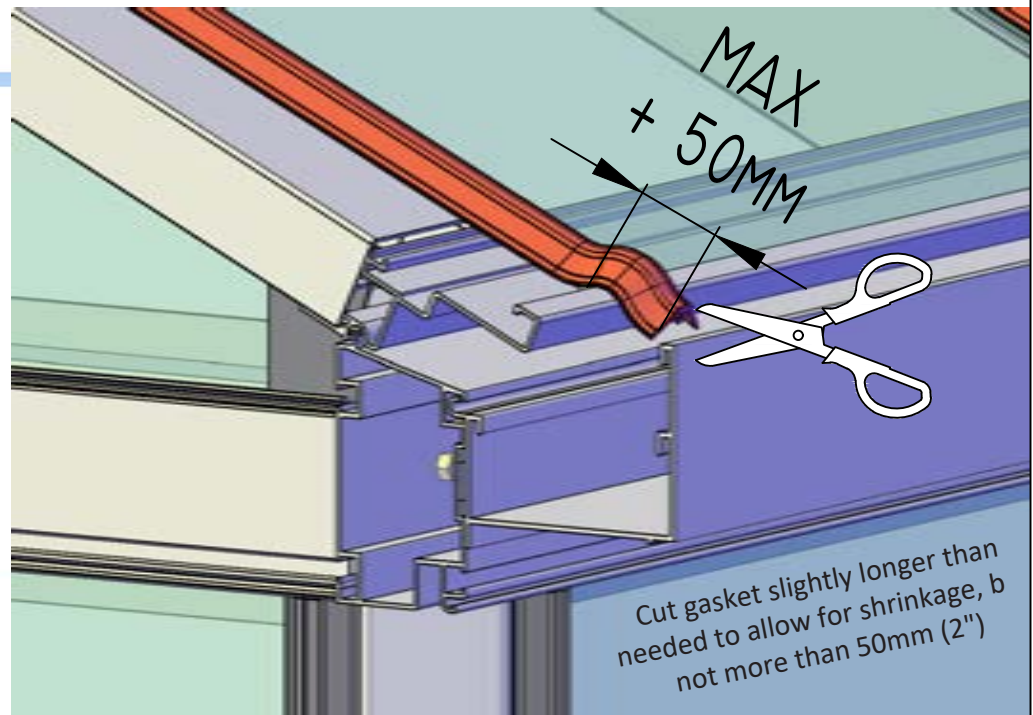
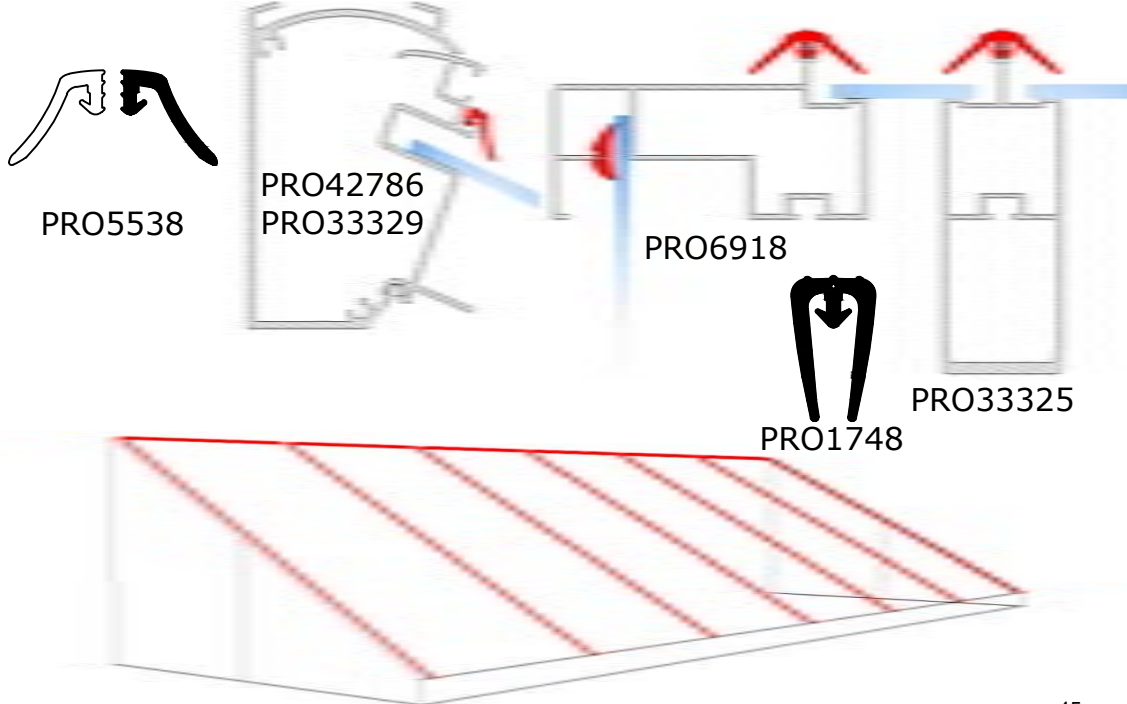
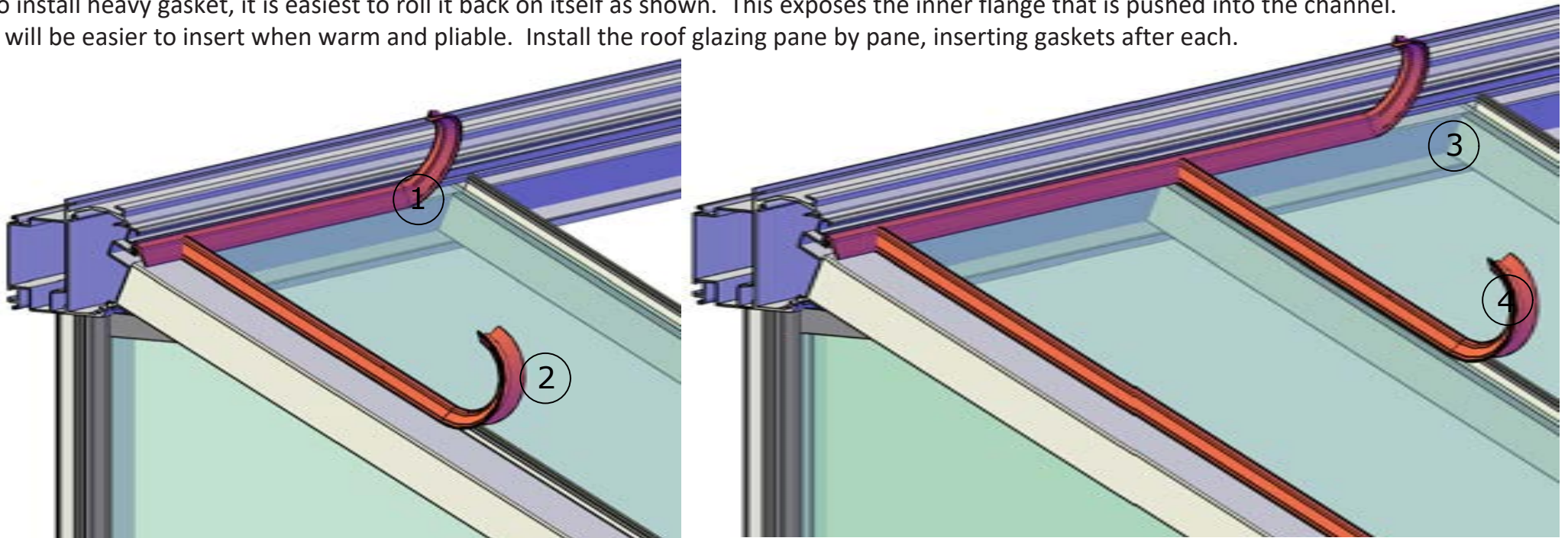

ACCESSORIES

This section contains many of the optional accessories.

You will have some, but likely not all, items seen in this section.

IMPORTANT: Scan the QR codes below to take you to our accessories installation video on YouTube and to our accessories page on our website.

QR Code for Website



QR Code for Accessory
Video on YouTube



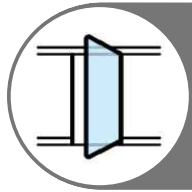

OPTIONAL UPGRADE: Hinged Door

HD



IMPORTANT: Find Janssens Accessory installation video on our site here:

<https://www.exaco.com/greenhouse-victorian.php>

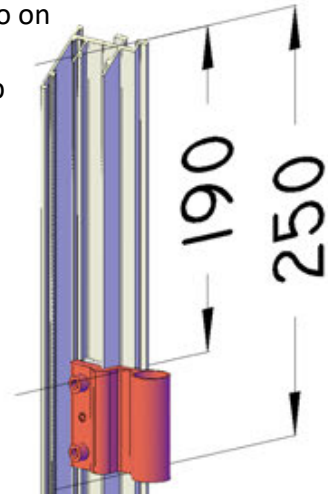
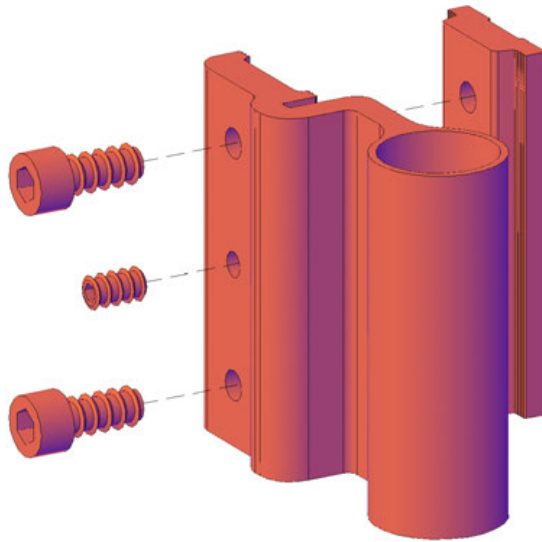



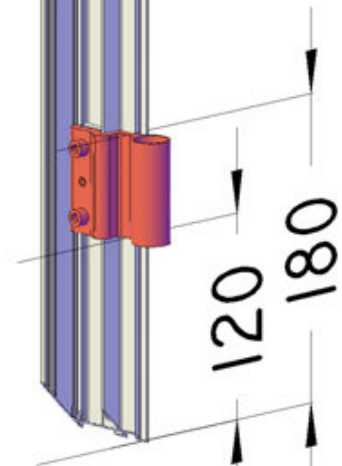
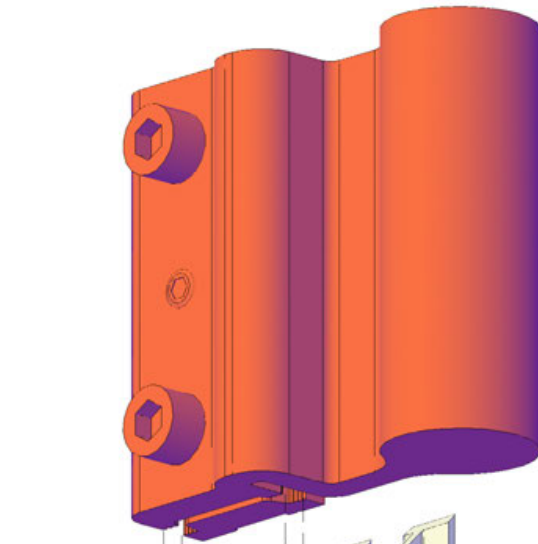
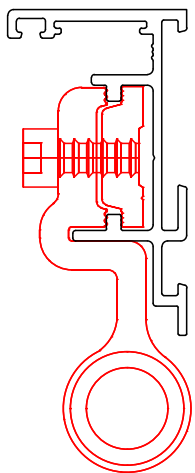

Hinges in door jamb will need to be adjusted.
Distances are in millimeters.

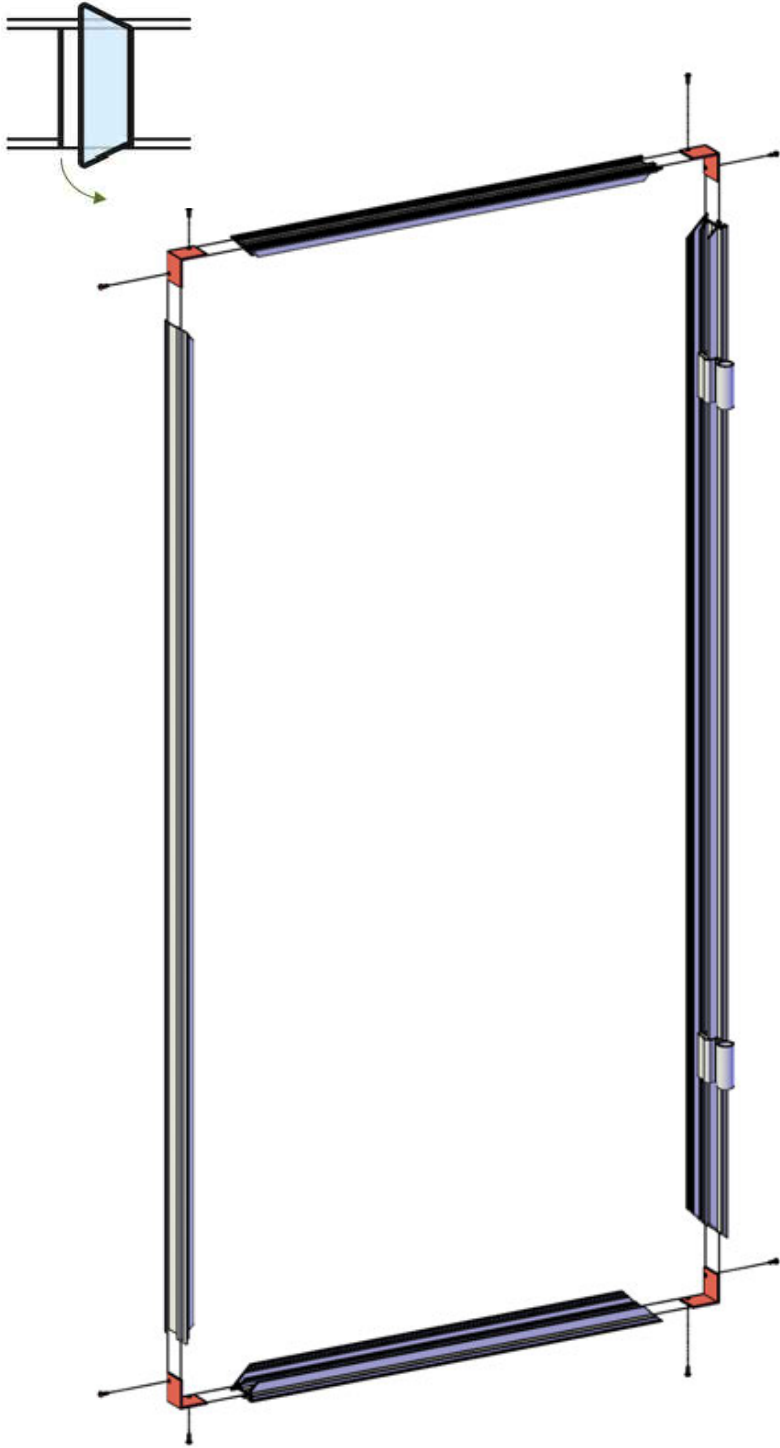

HD 1



	ITEM	PC.	L
	L 40X40	4 PC	36 MM
	PRO6280	2 PC	703 MM
	PRO6280	2 PC	1.441 MM
	PRO6280	2 PC	1.930 MM
	4,2 x 13	8 PC	

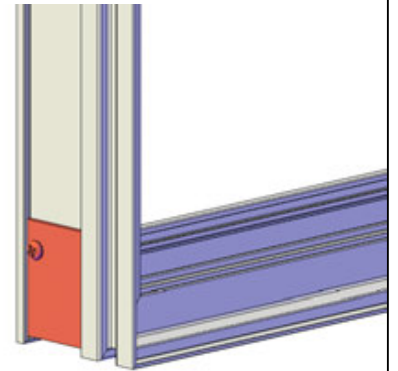
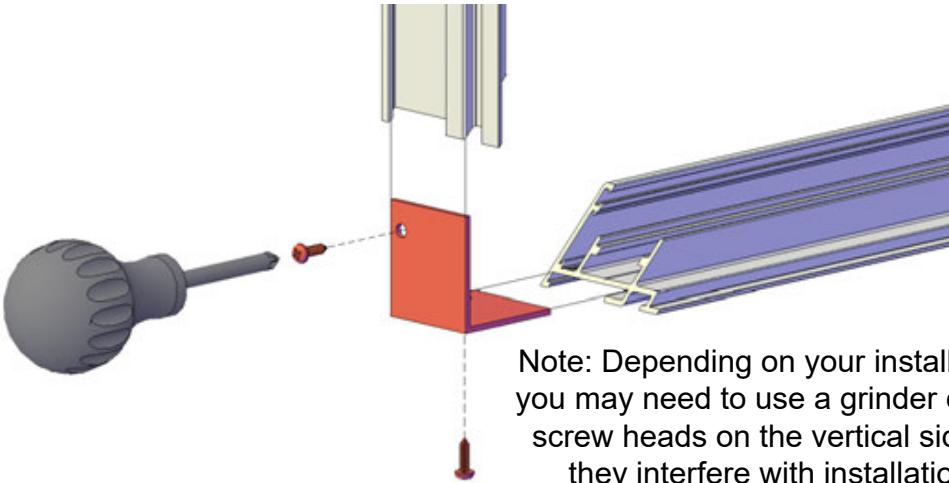
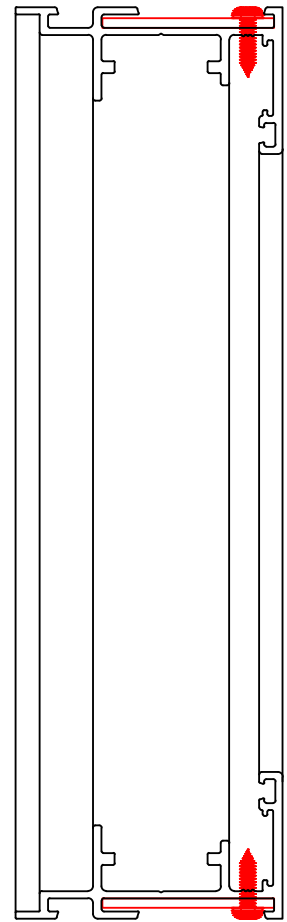

Note: Depending on your installation, you may need to use a grinder on the screw heads on the vertical sides if they interfere with installation.

Double Hinged door will need opening of 1441mm, 17mm from bolt holes on foundation frame.

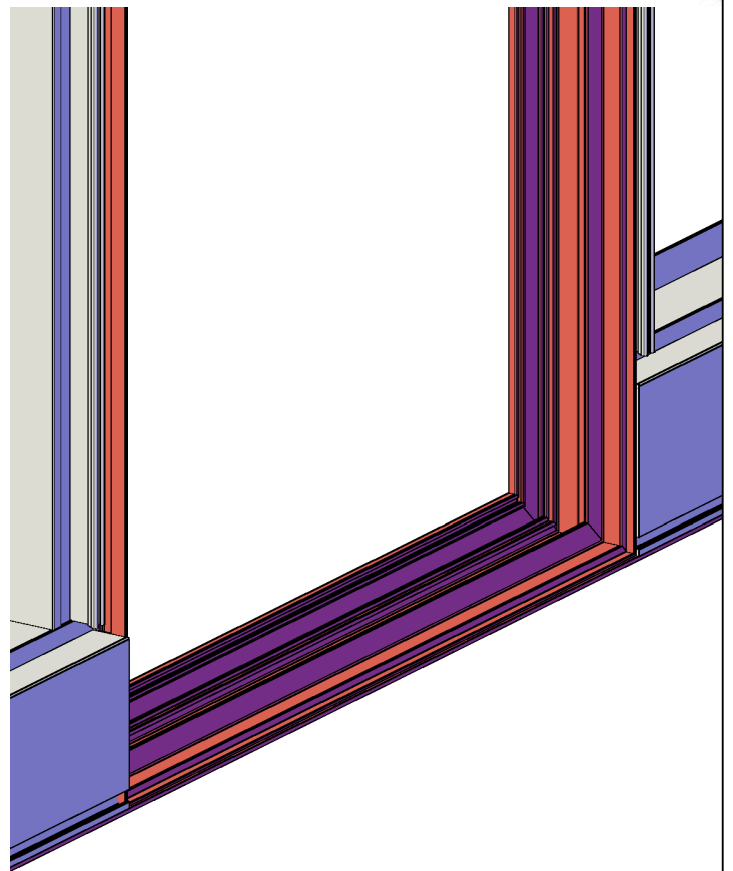
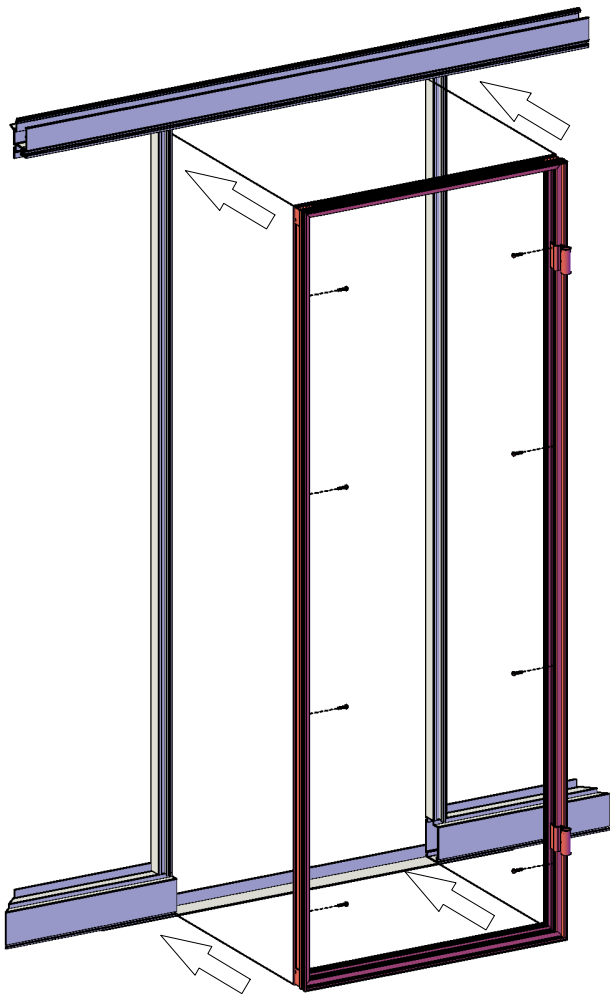
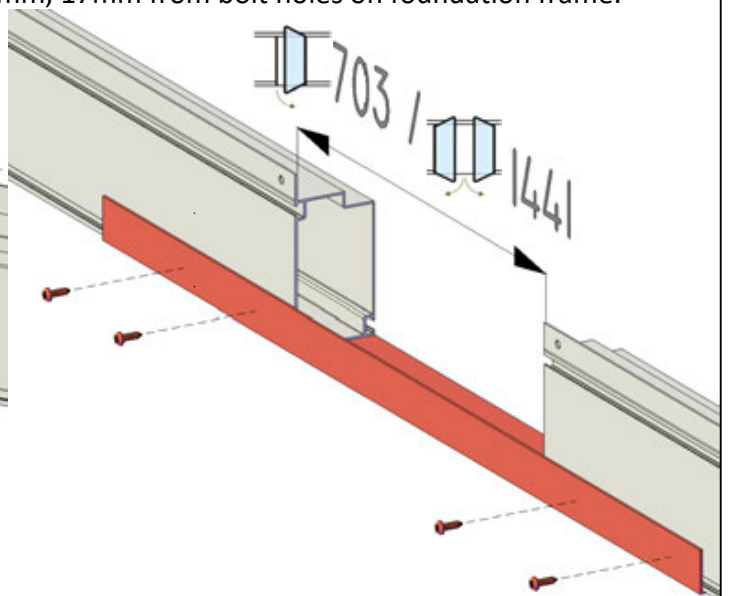
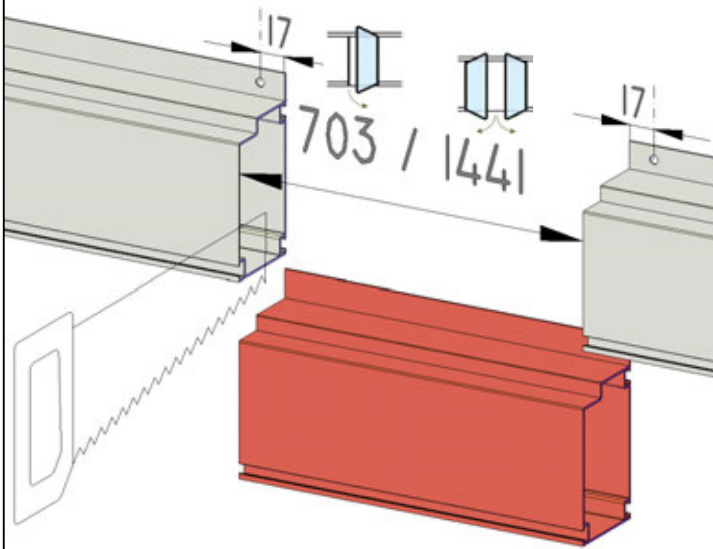

(Single door shown, double door jamb installation will be identical)

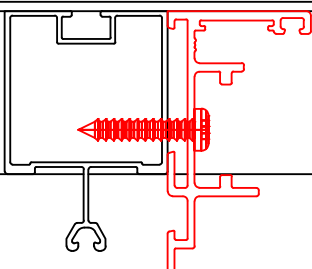

(view from top)

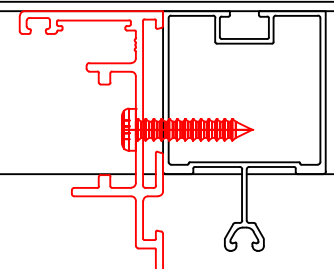

HD 3

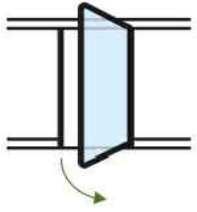

Single hinged door

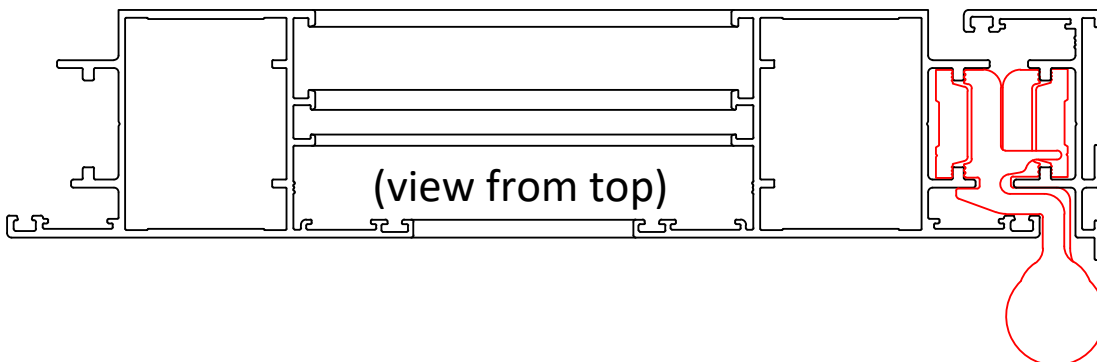
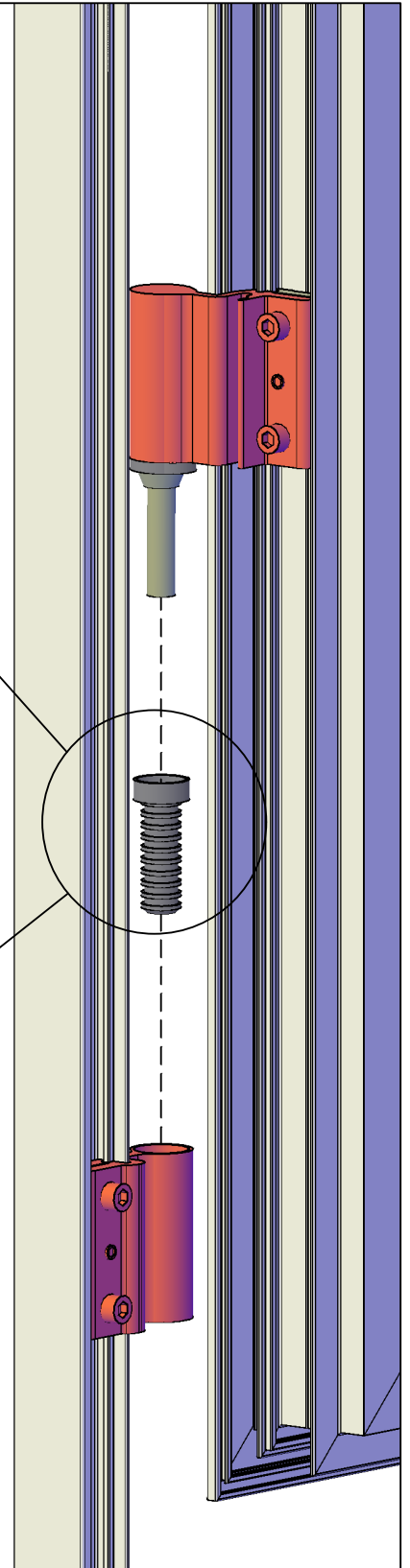
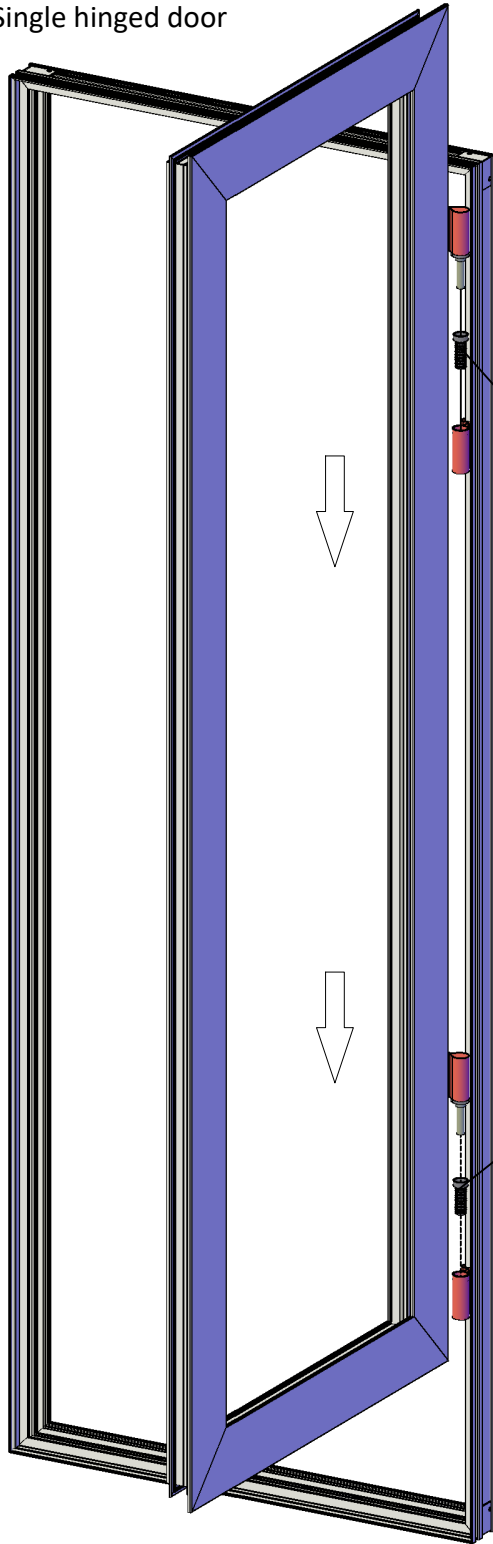

HD 4

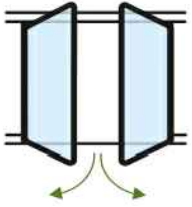

OPTION: Double Hinged Door

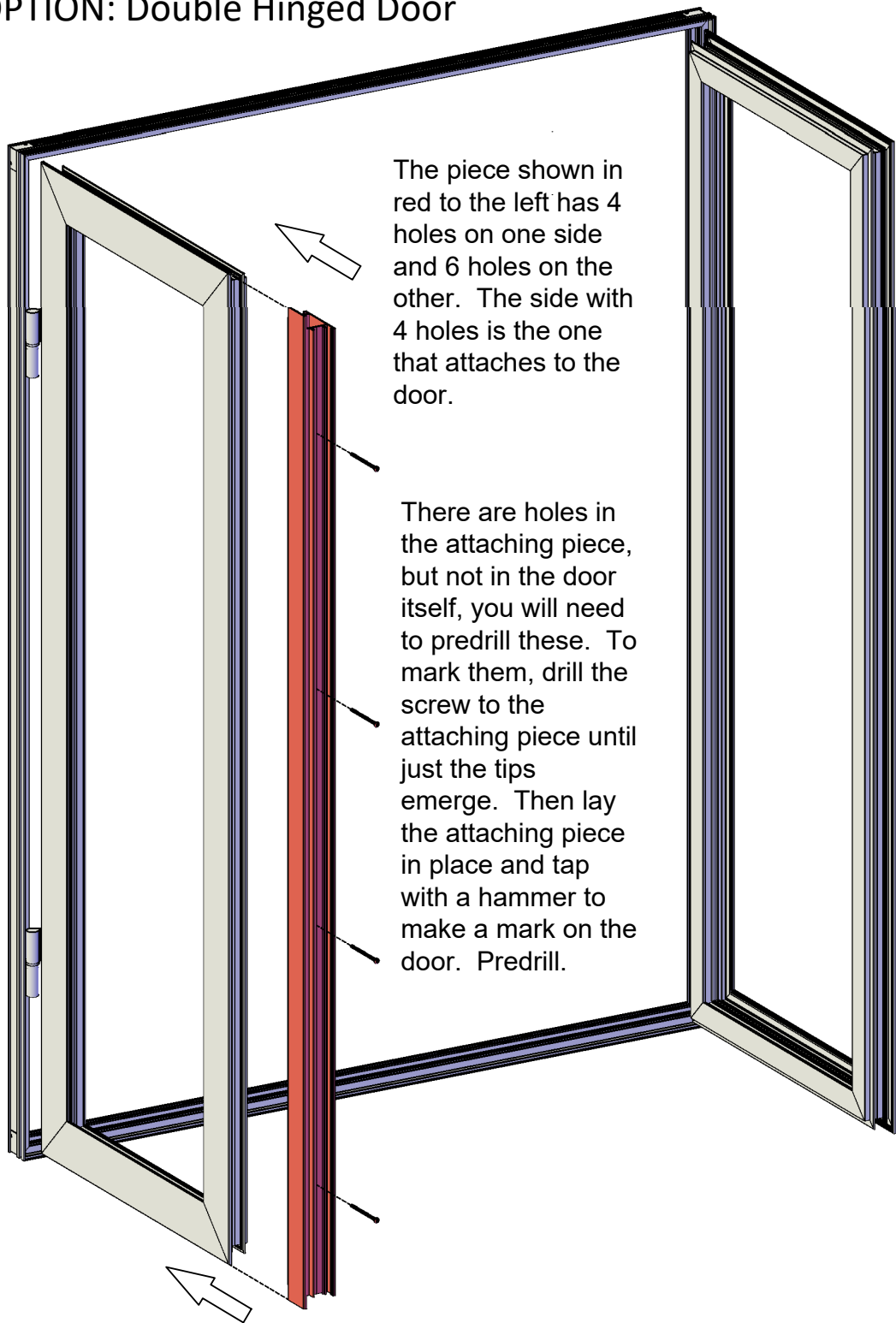

The piece shown in red to the left has 4 holes on one side and 6 holes on the other. The side with 4 holes is the one that attaches to the door.

There are holes in the attaching piece, but not in the door itself, you will need to predrill these. To mark them, drill the screw to the attaching piece until just the tips emerge. Then lay the attaching piece in place and tap with a hammer to make a mark on the door. Predrill.

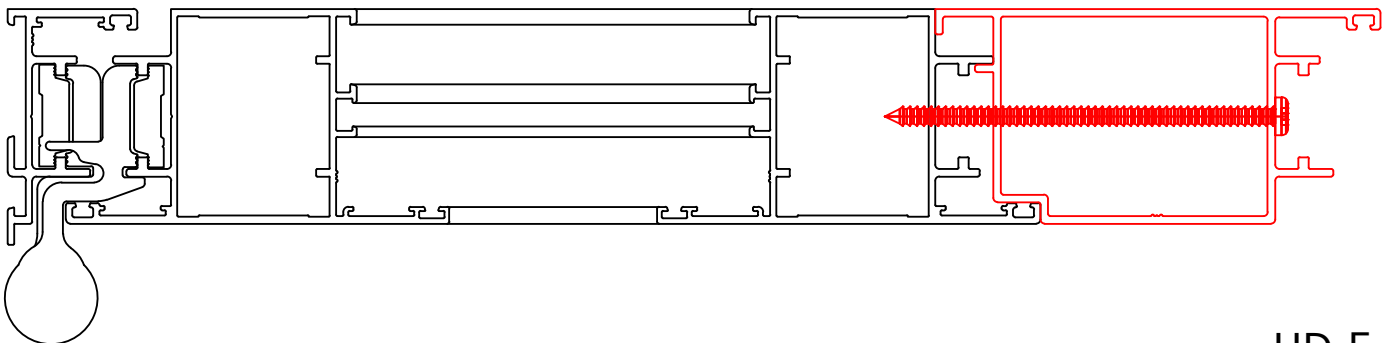

HD 5

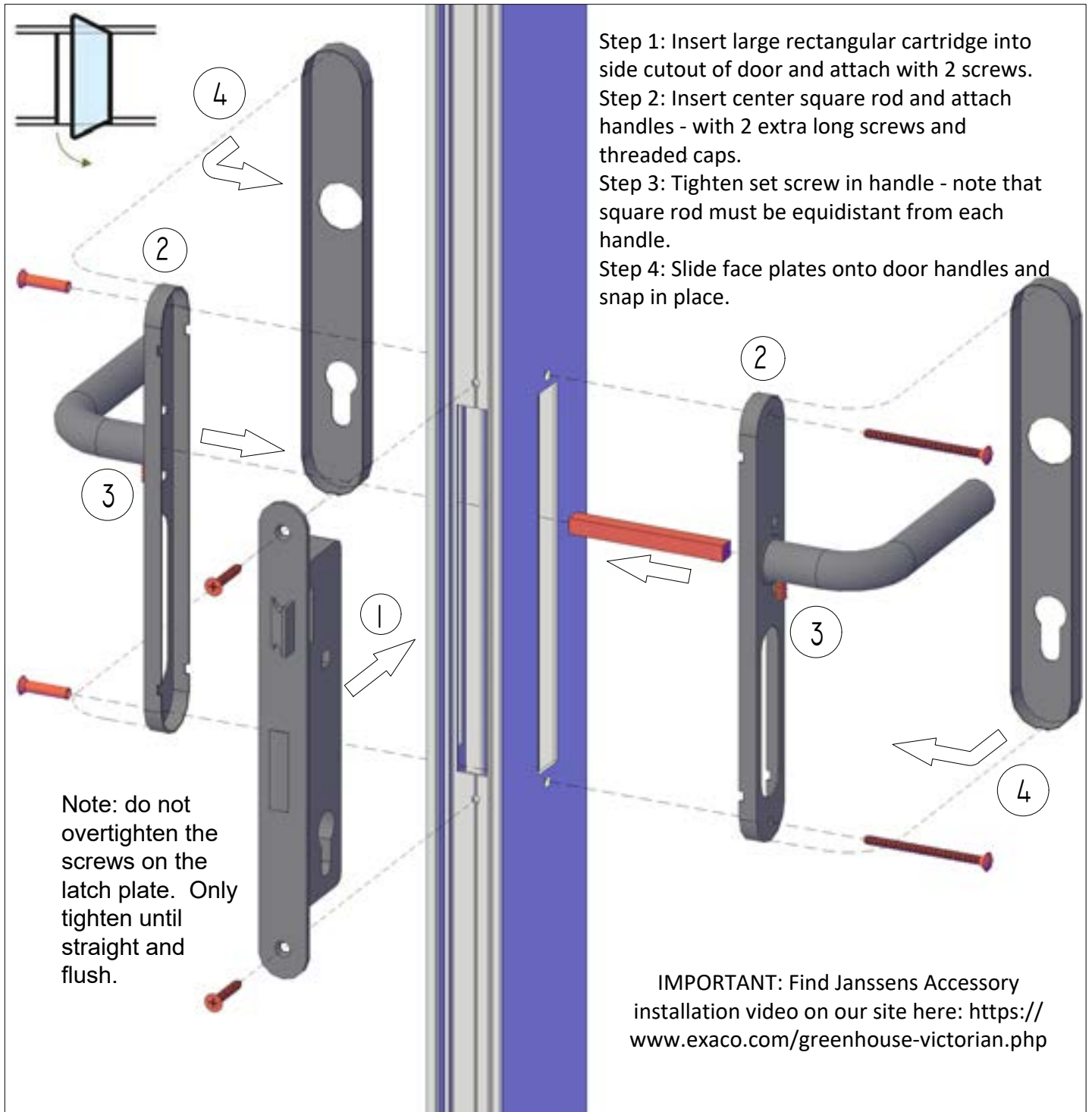

HD 6

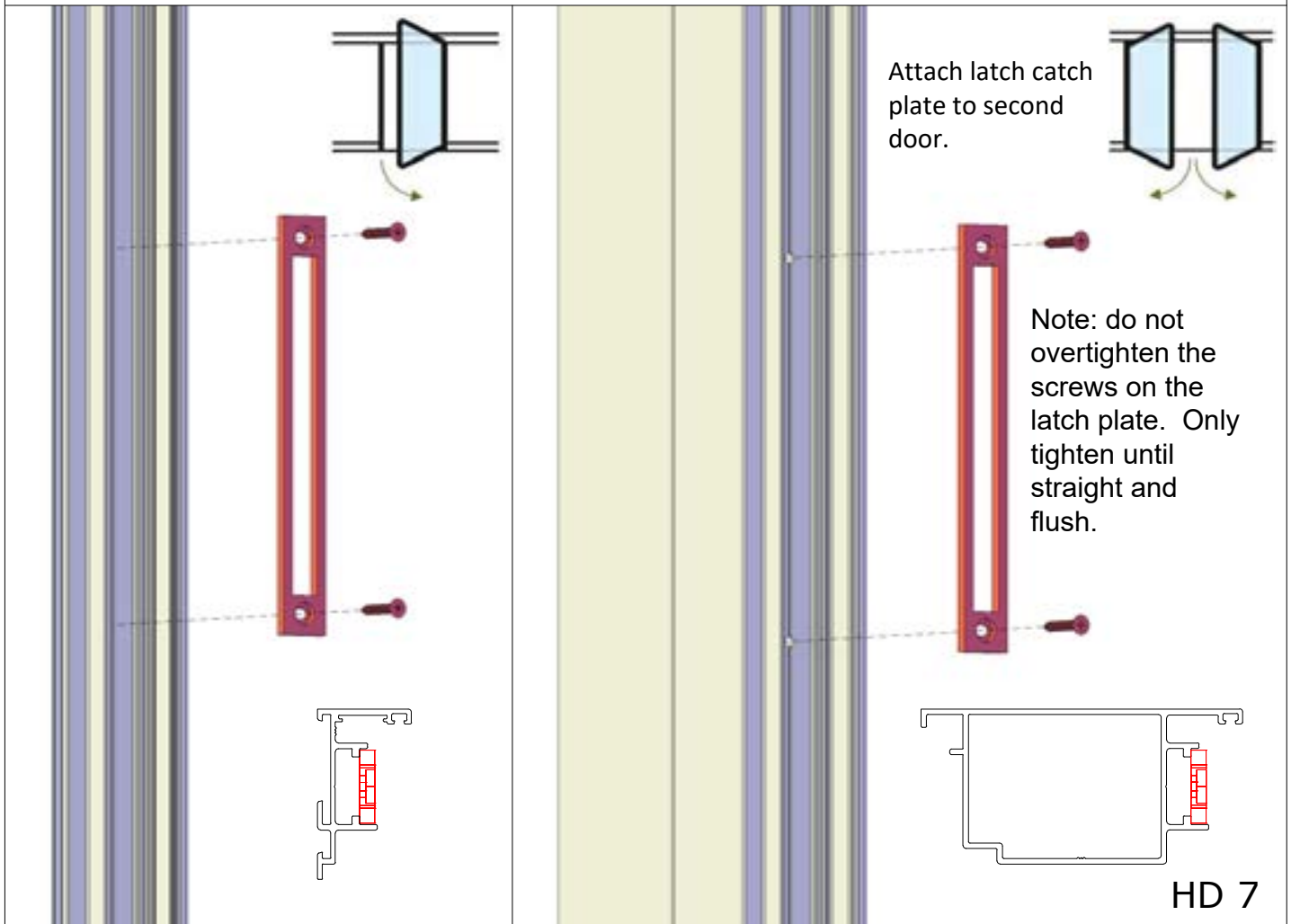
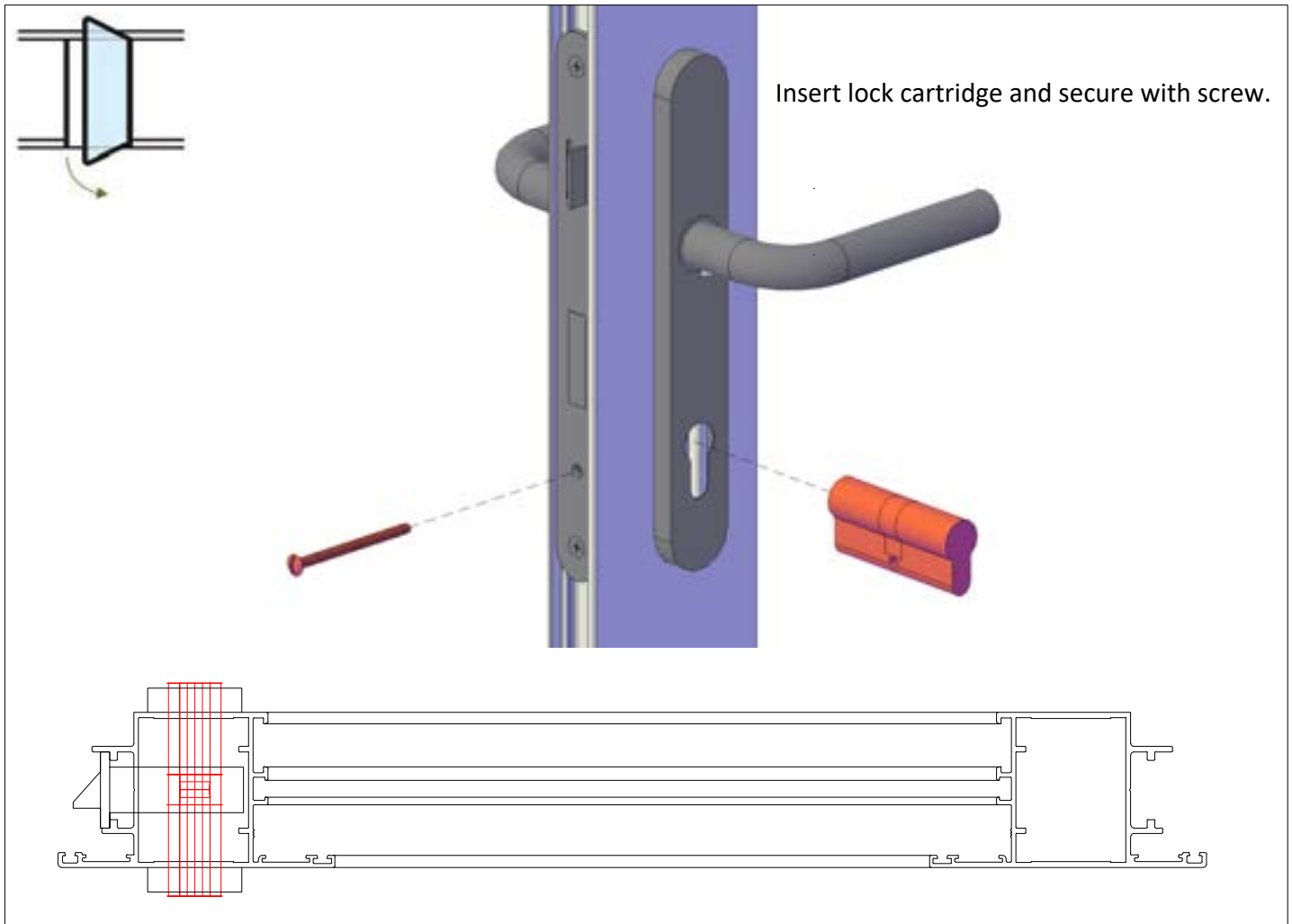

For the next step, we recommend placing the door flat until glass is installed.

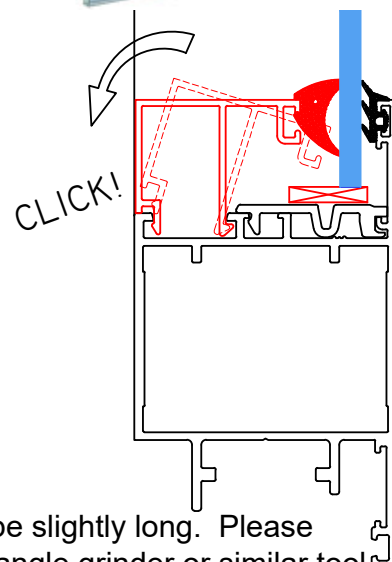
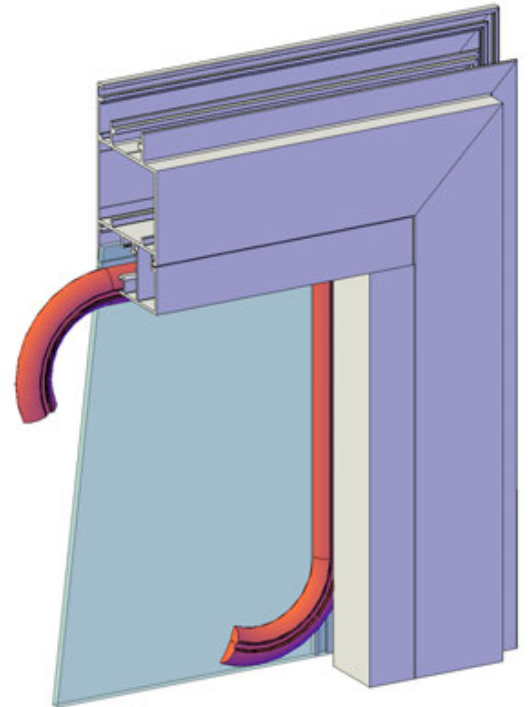
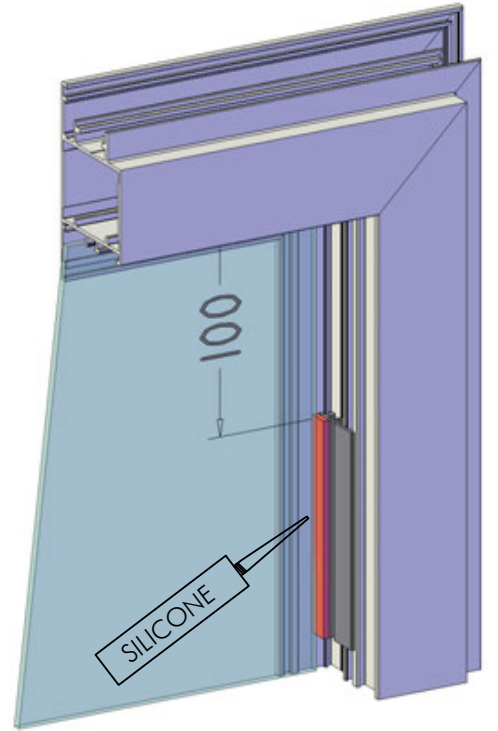
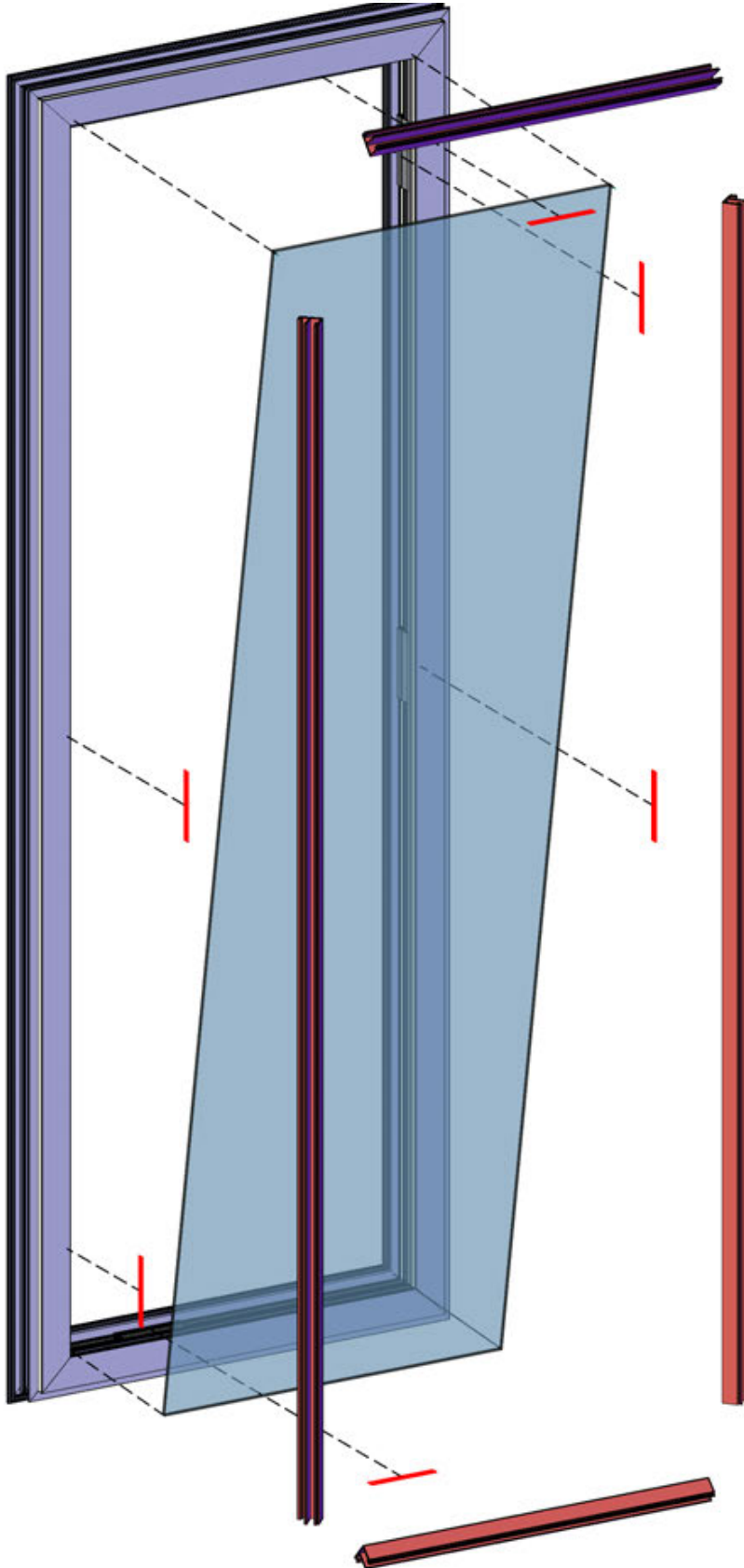
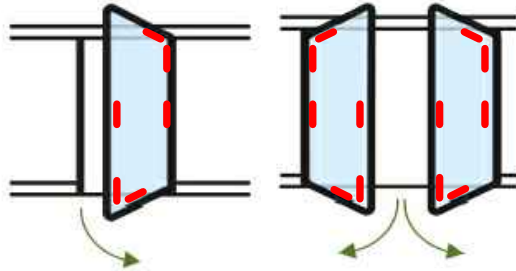

NOTE: the horizontal glazing strips shown in red above may be slightly long. Please measure and trim to fit your door using a hacksaw, hand file, angle grinder or similar tool.

HD 8

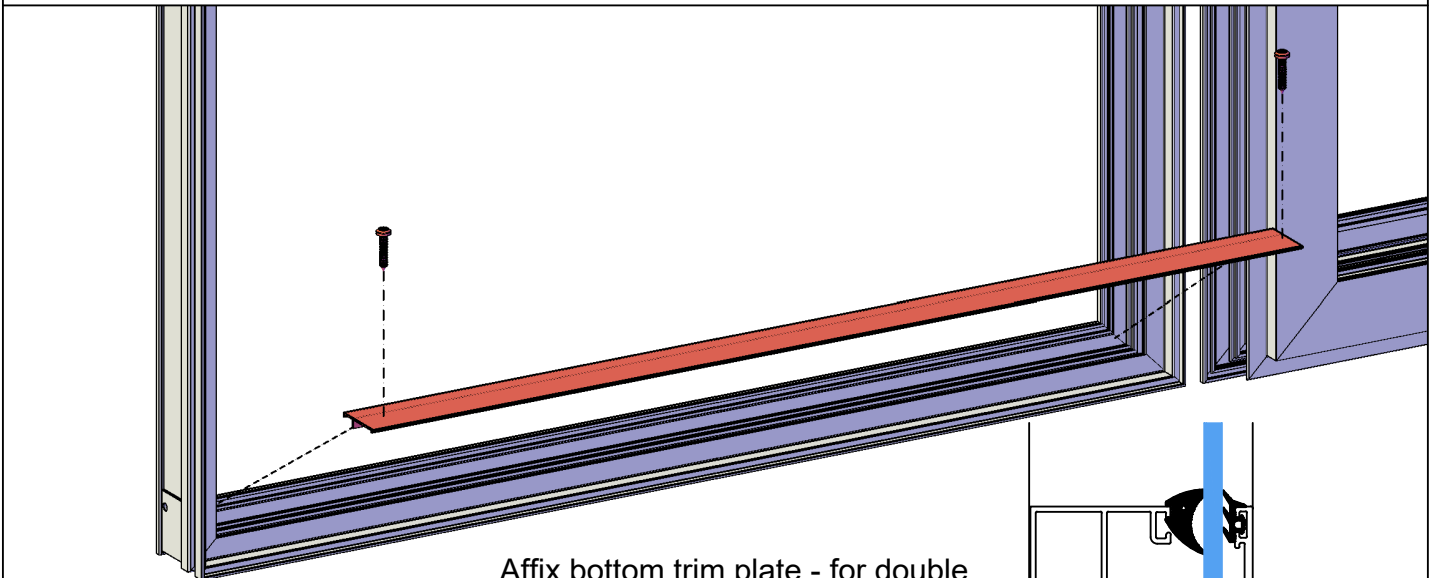
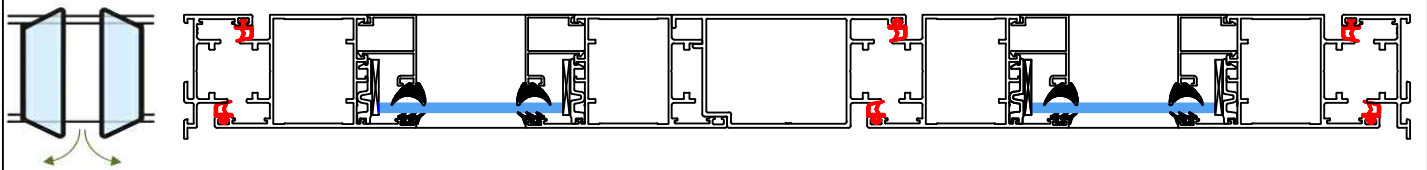
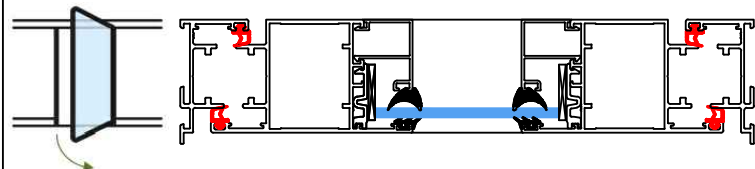
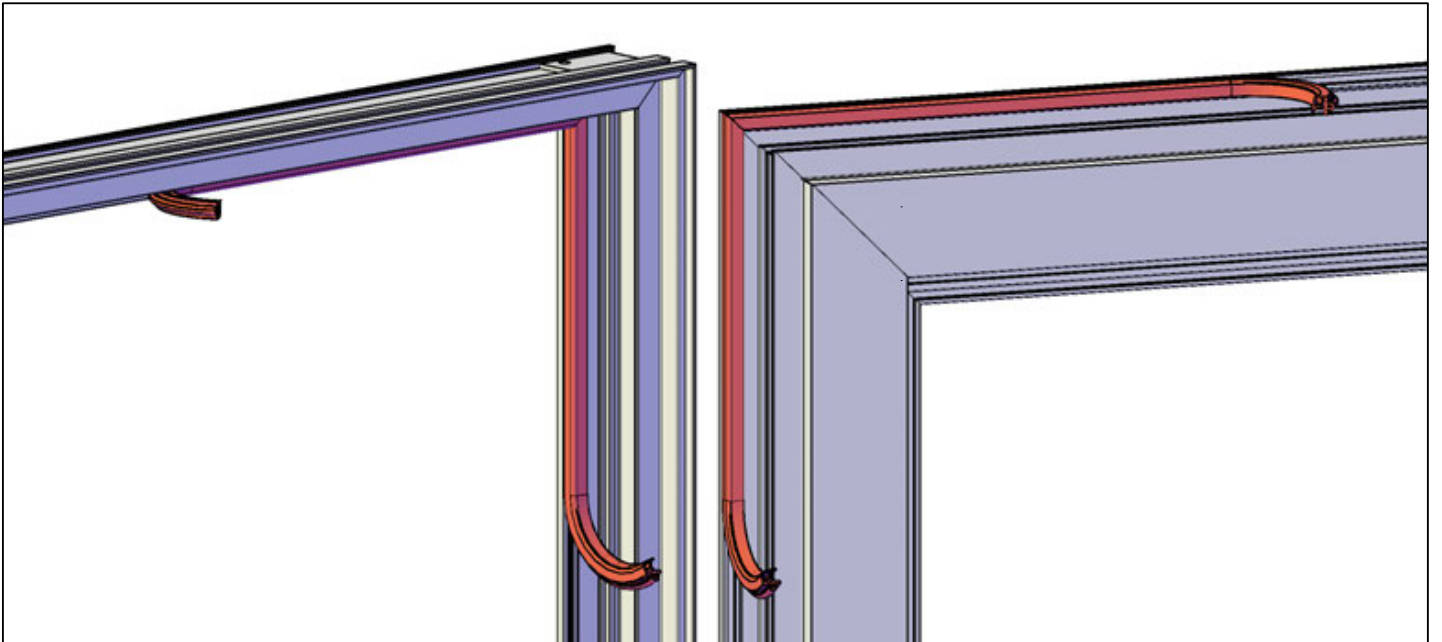

Affix bottom trim plate - for double doors see next page.

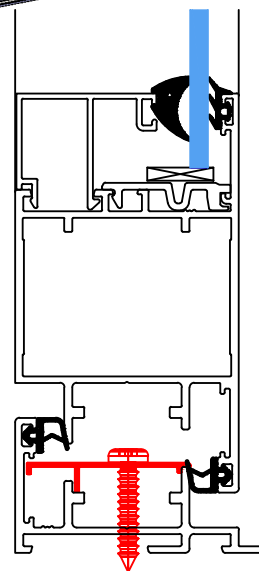

HD 9

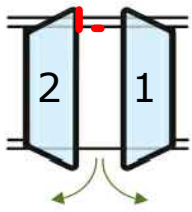

This page only applies to double hinged doors.

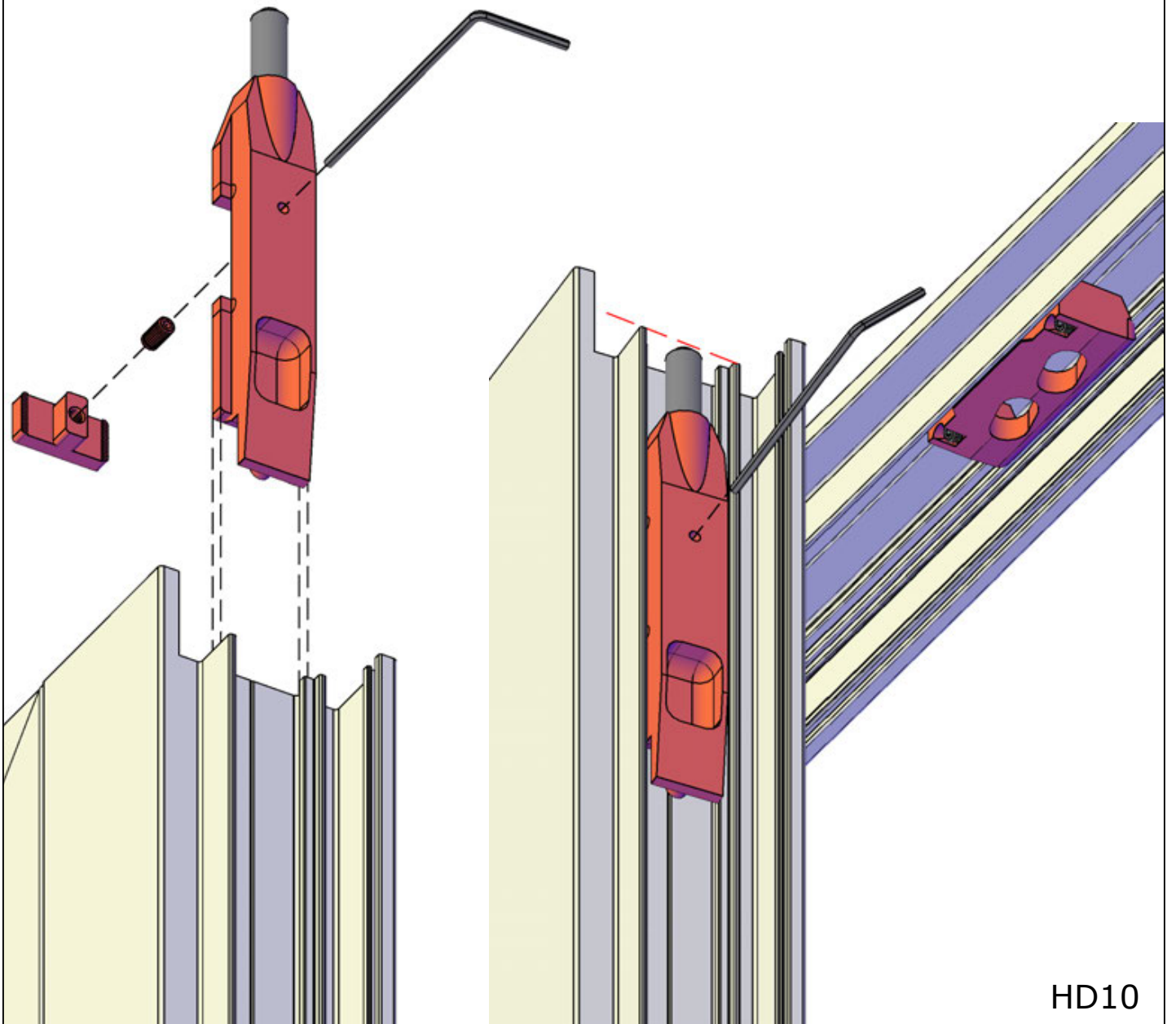
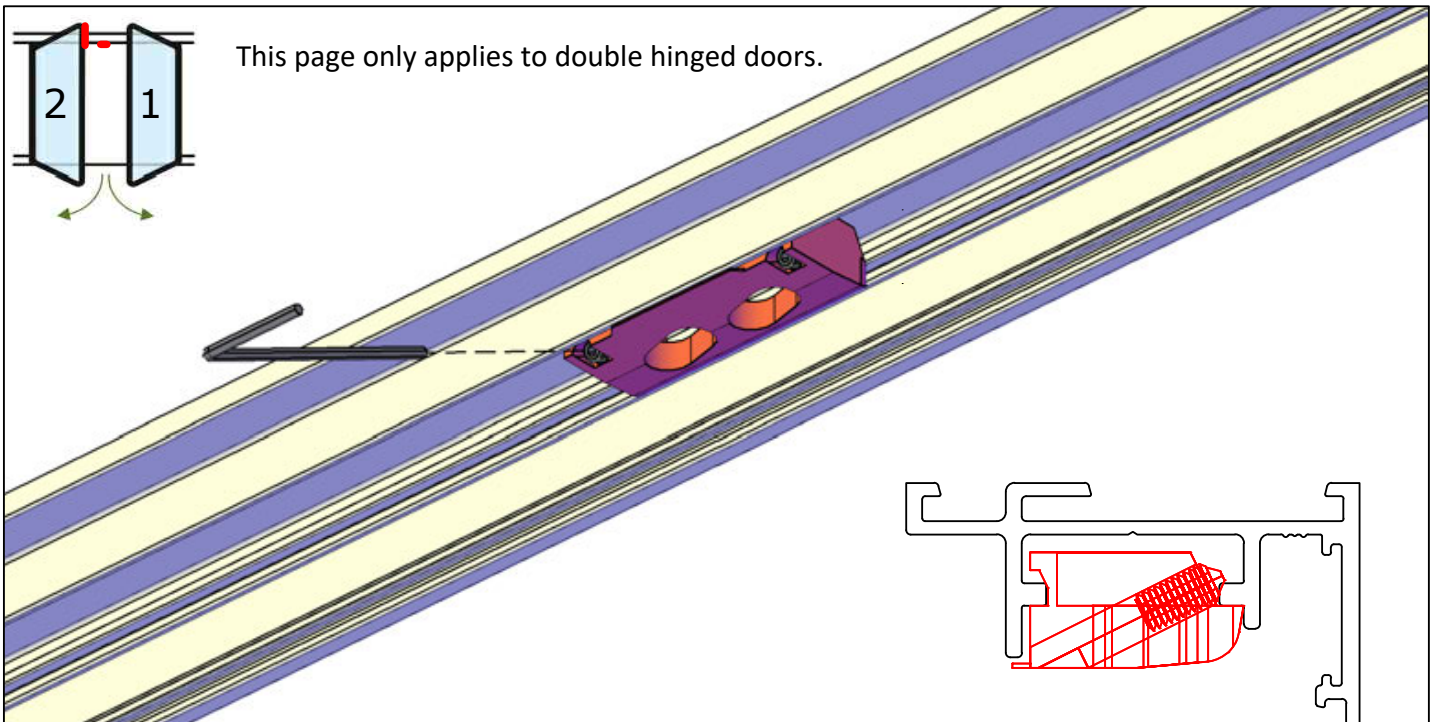

HD10

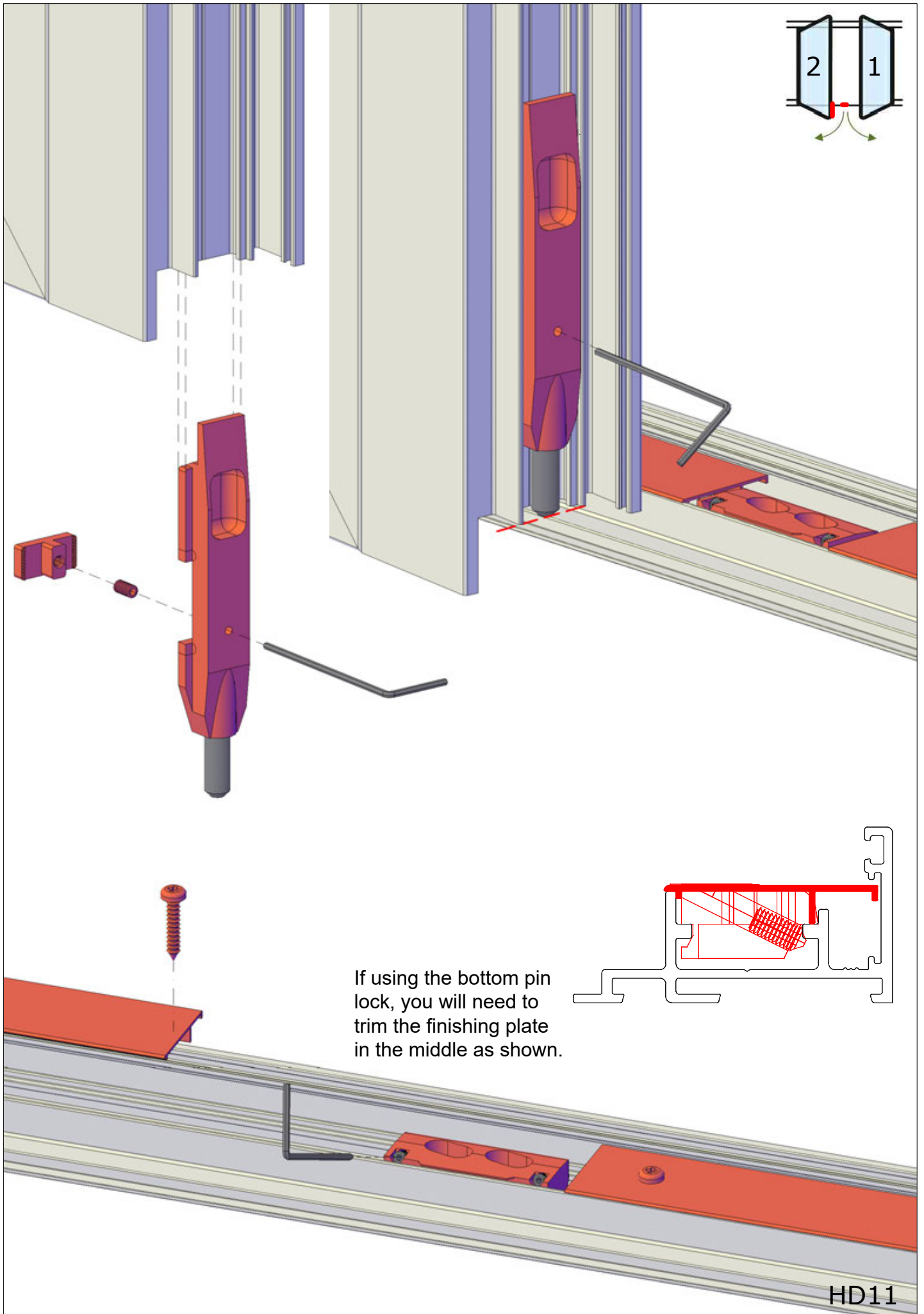

If using the bottom pin lock, you will need to trim the finishing plate in the middle as shown.

HD11



HINGE
ADJUSTMENT
(Left to Right)

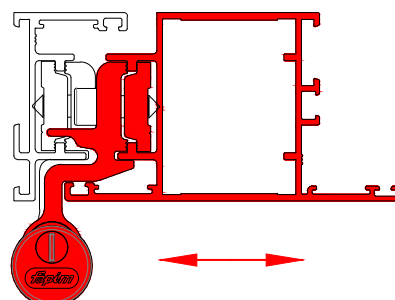
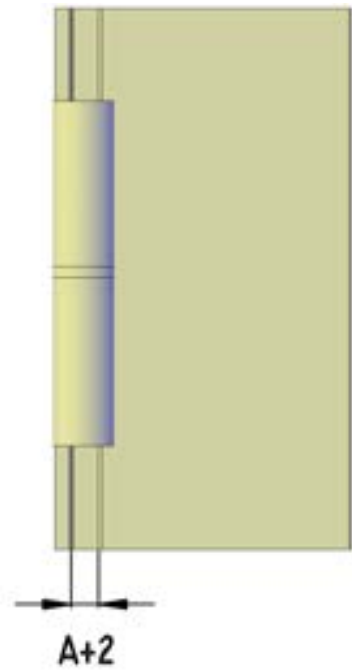
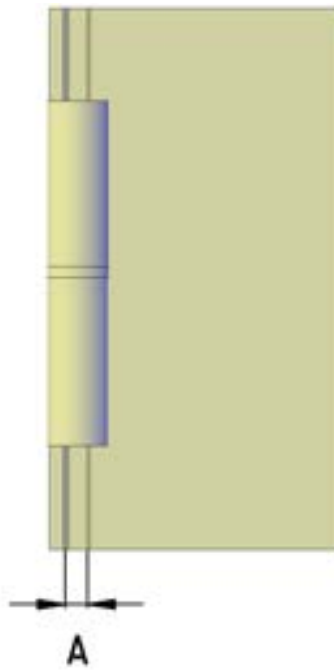
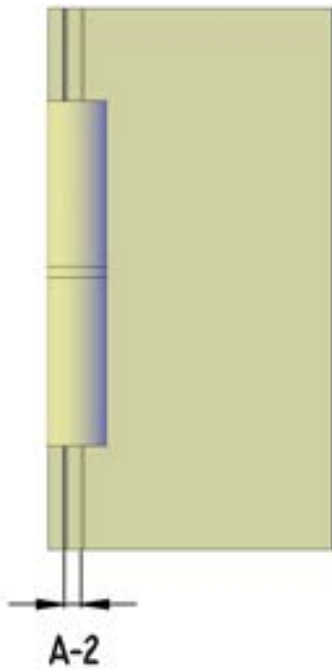
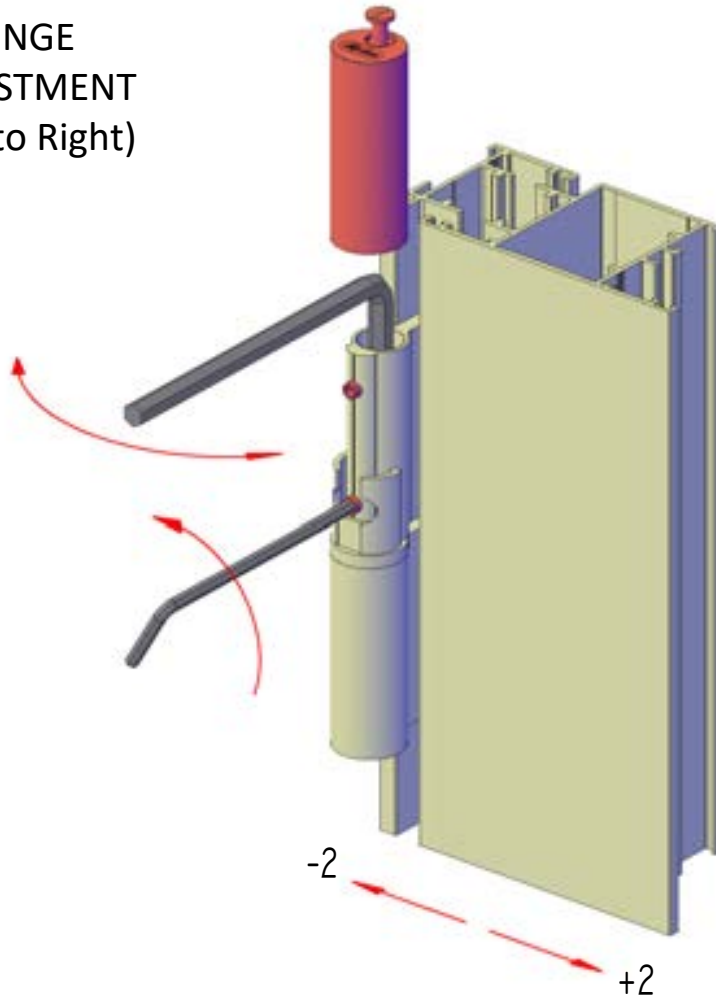

HD12



HINGE ADJUSTMENT (Up)

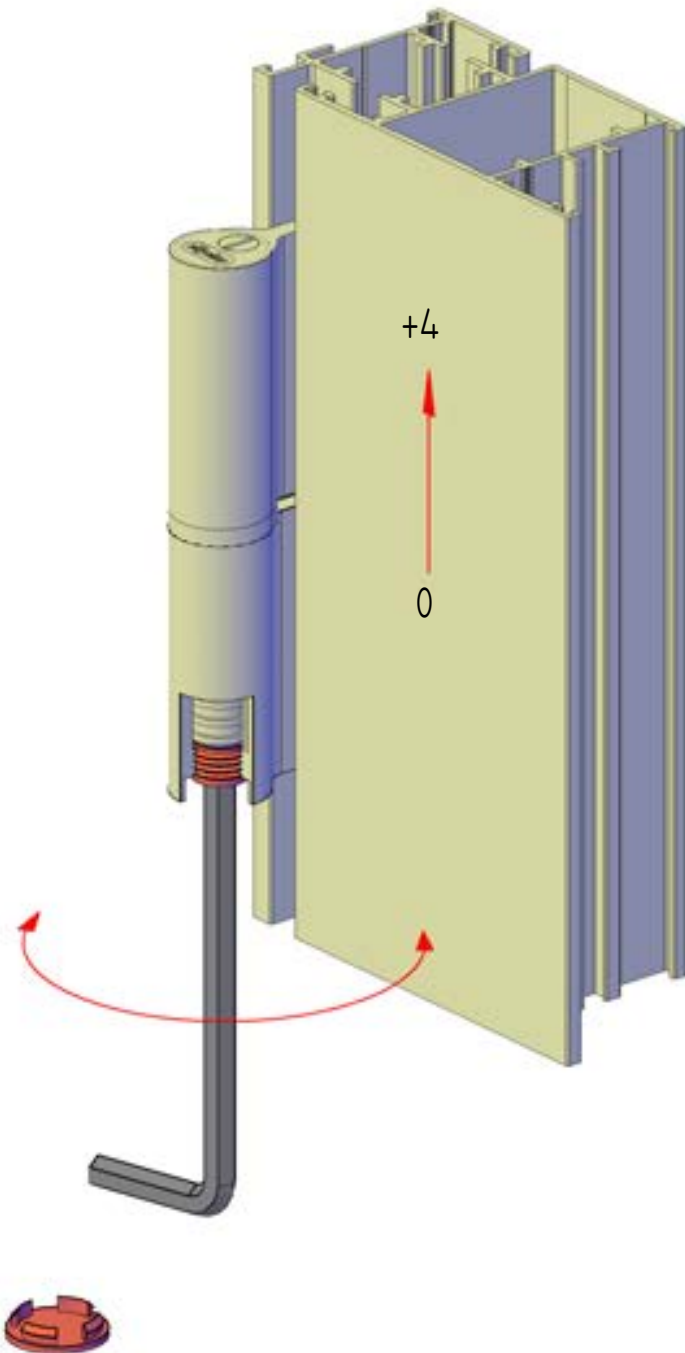

HINGE ADJUSTMENT (Front/Back)

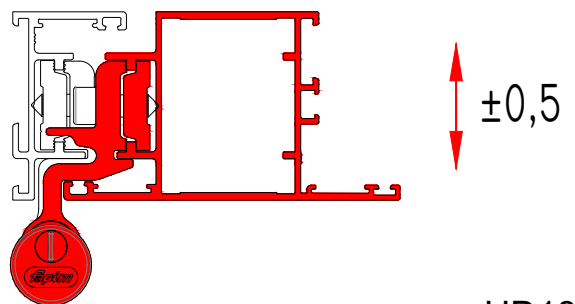
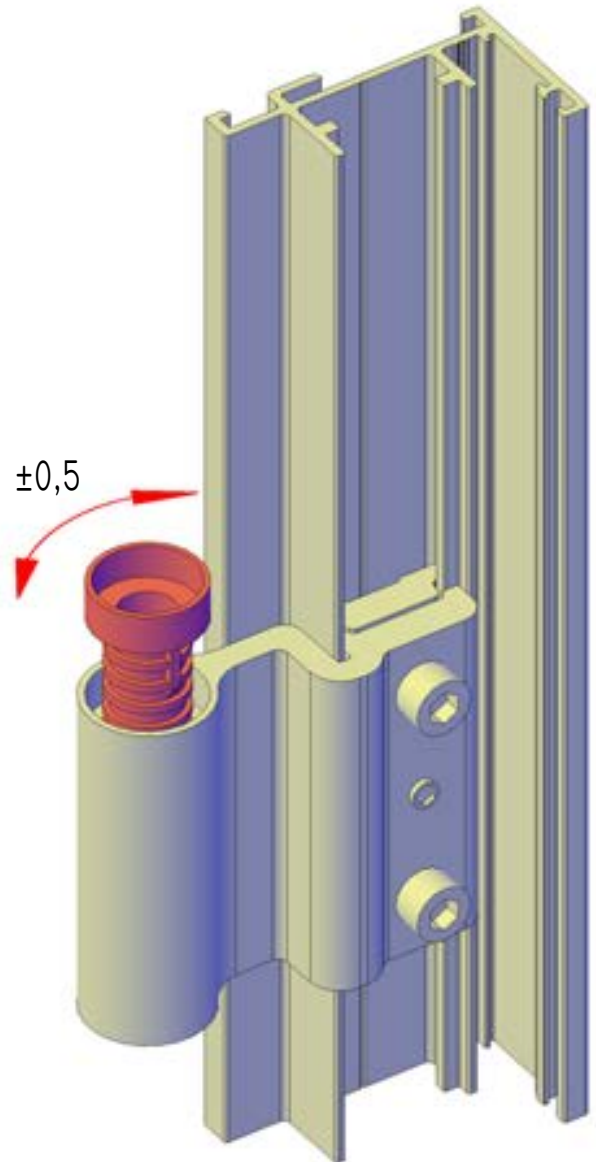

HD13

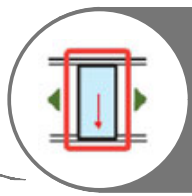

OPTIONAL UPGRADE: Fall 2022 Low Threshold for Sliding Door/s

KSD

KSD_70



Single sliding door opening
should be 703mm

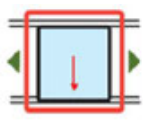

KSD_144

Double sliding door opening
should be 1441mm

Cut foundation
frame 17mm from
bolt hole

Cut foundation
frame 17mm from
bolt hole

703 / 1441

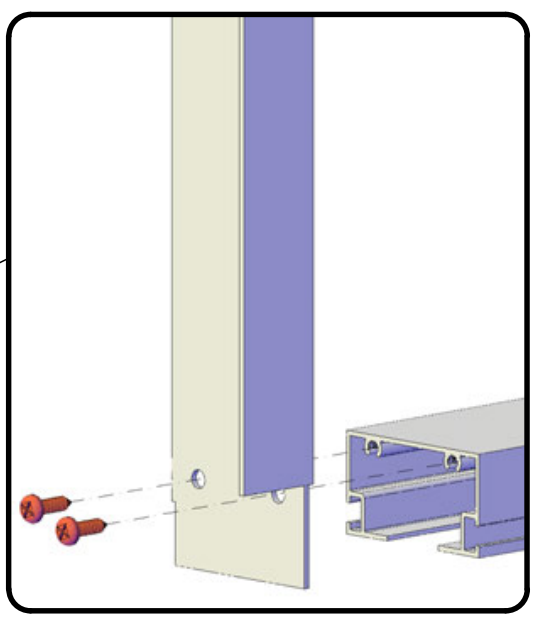
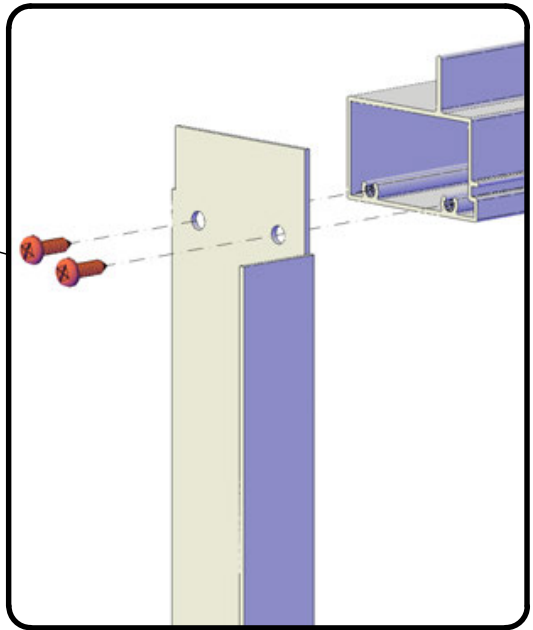
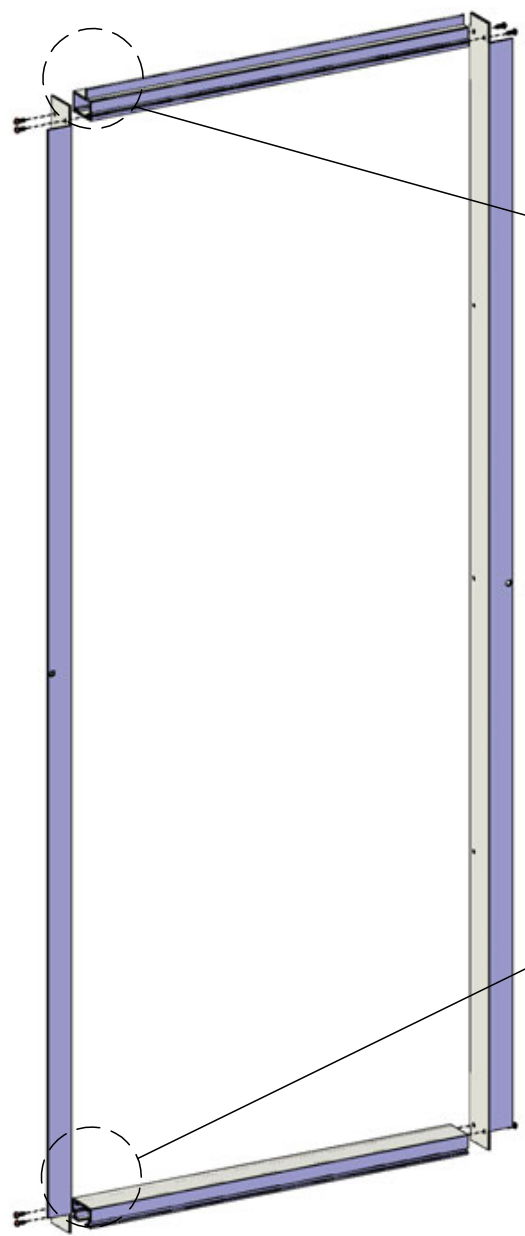
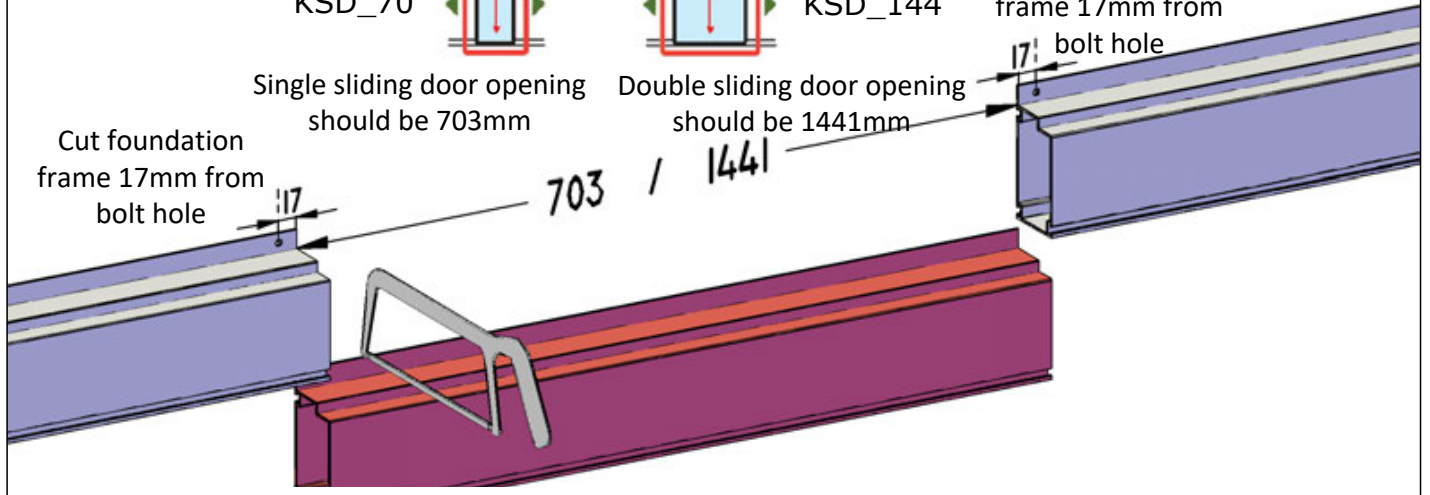

KSD_1

OPTIONAL UPGRADE: Fall 2022 - Low Threshold for Sliding Door/s

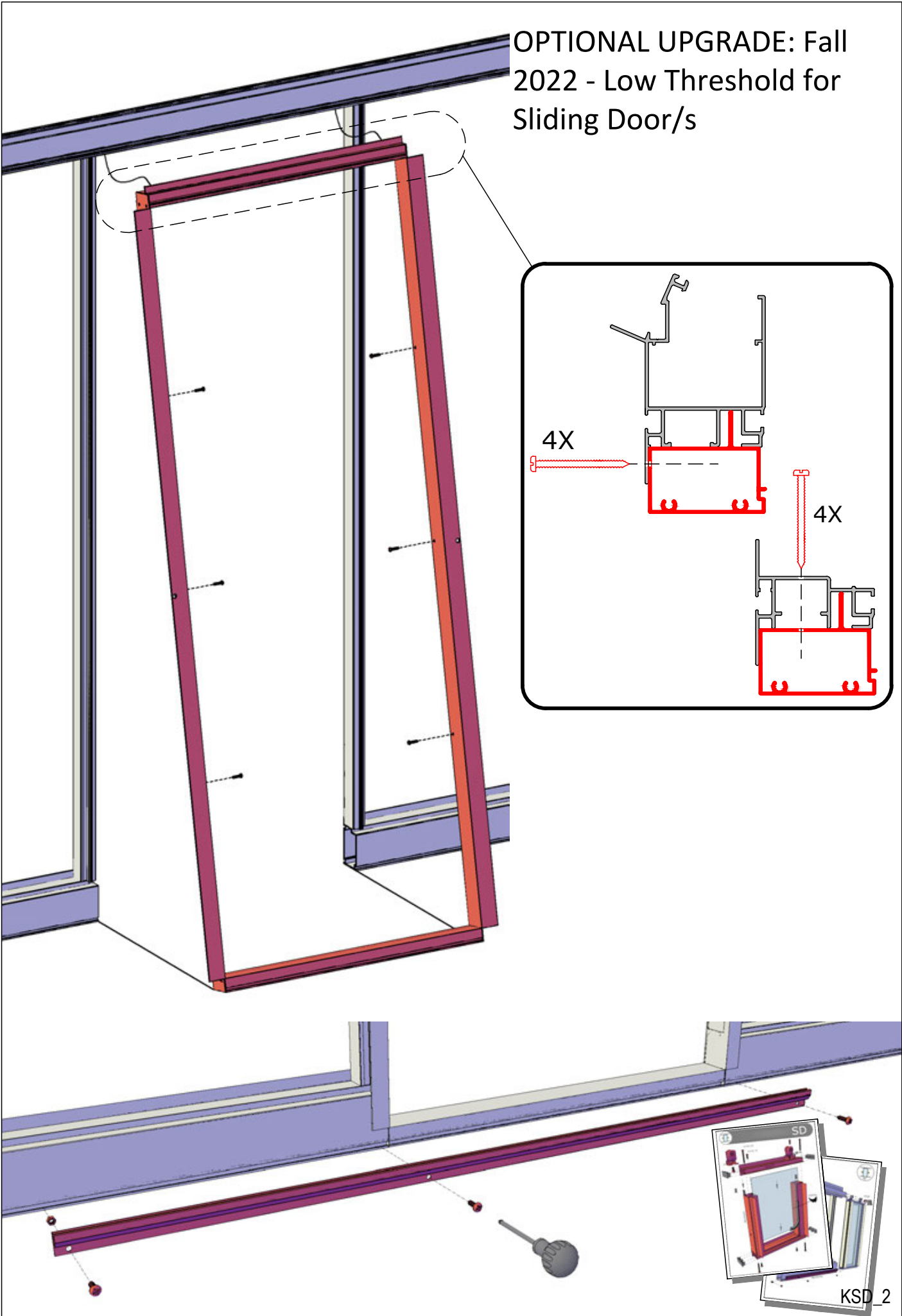

Optional Upgrade: Lock installation with Low Threshold Kit

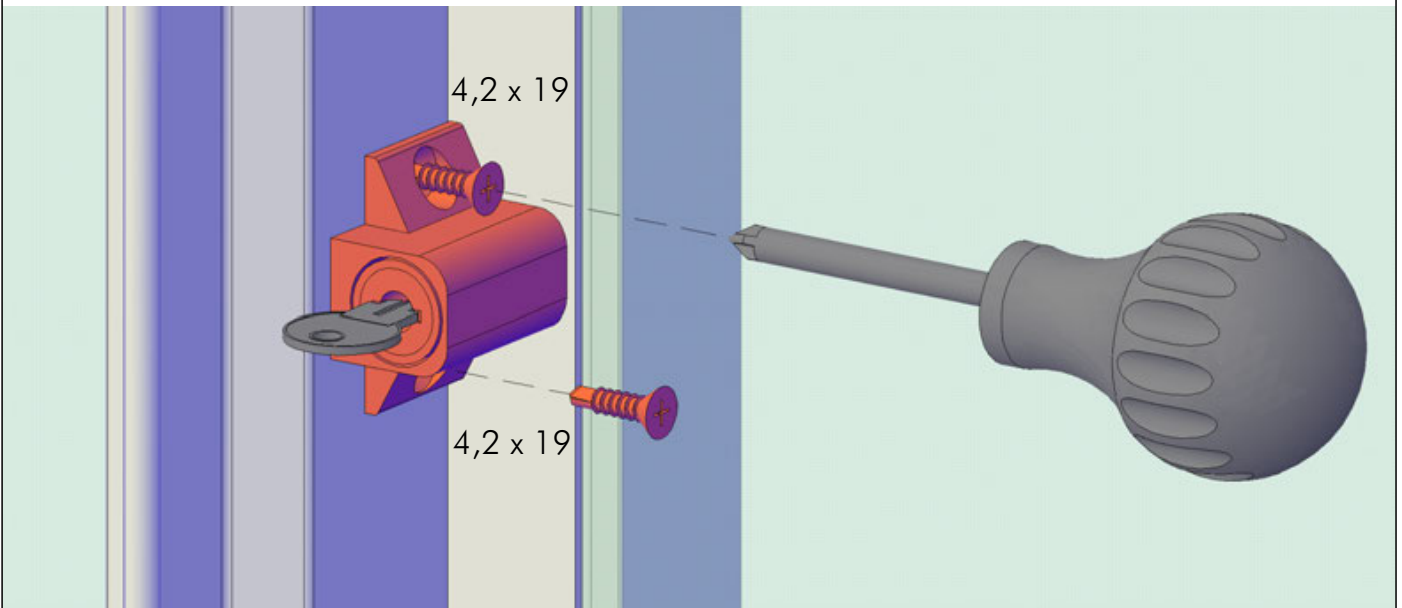
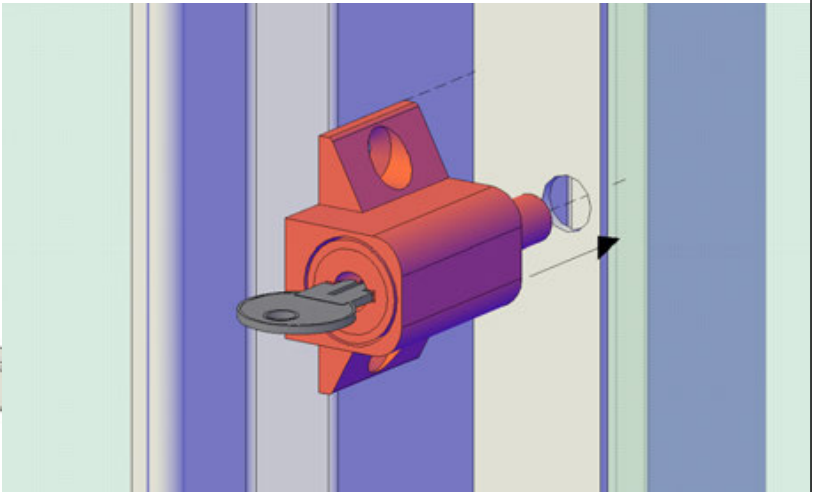
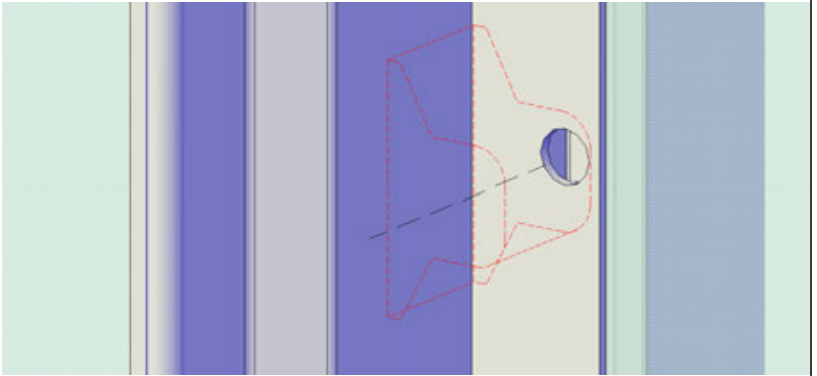
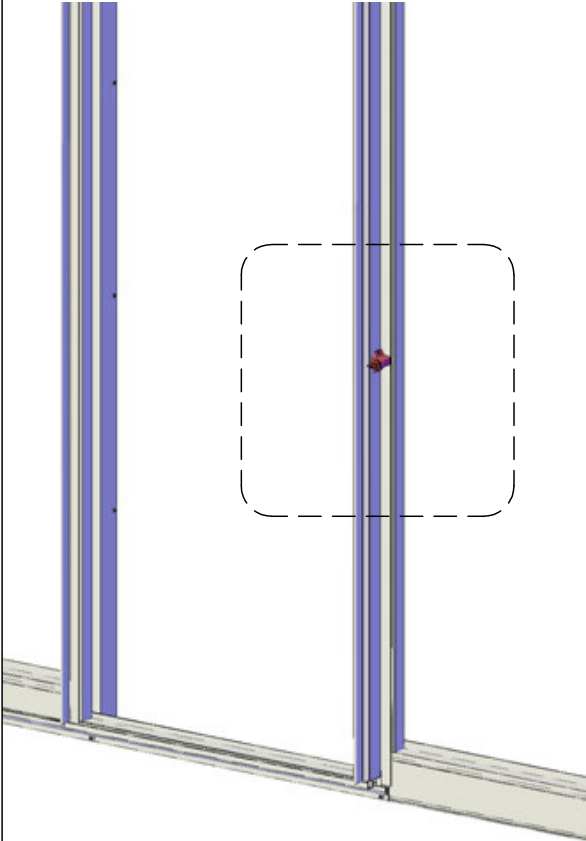
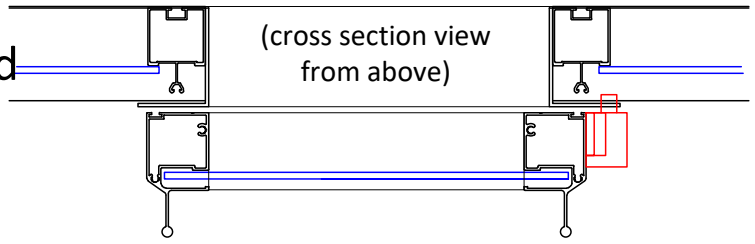
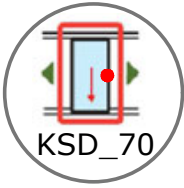
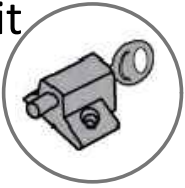

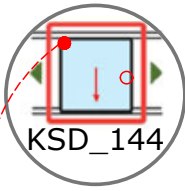
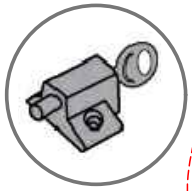

Optional Upgrade: Lock installation with Low Threshold Kit (Double Sliding Door - installed on the inside on one door)

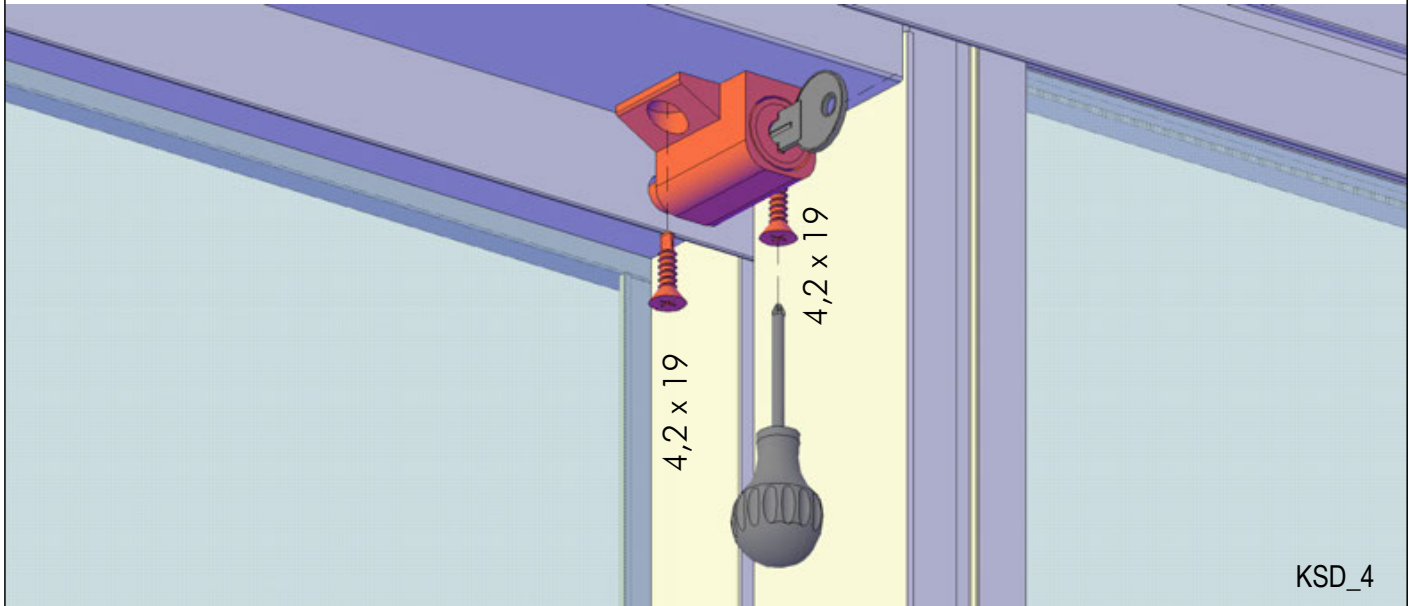
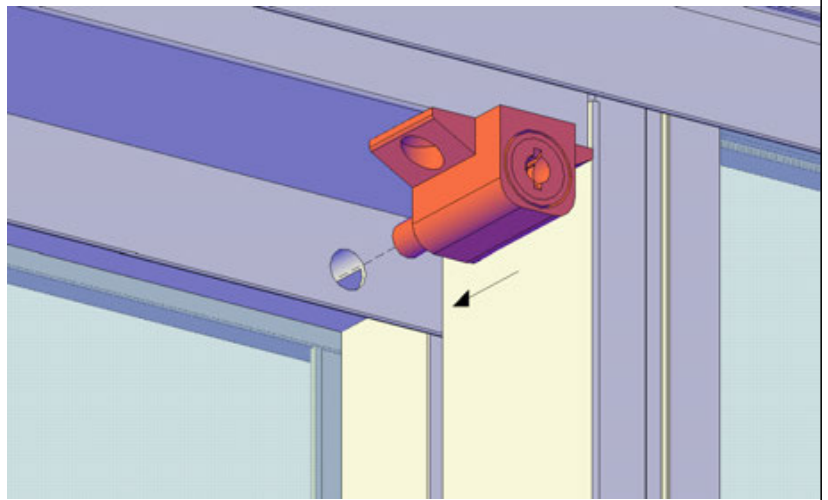
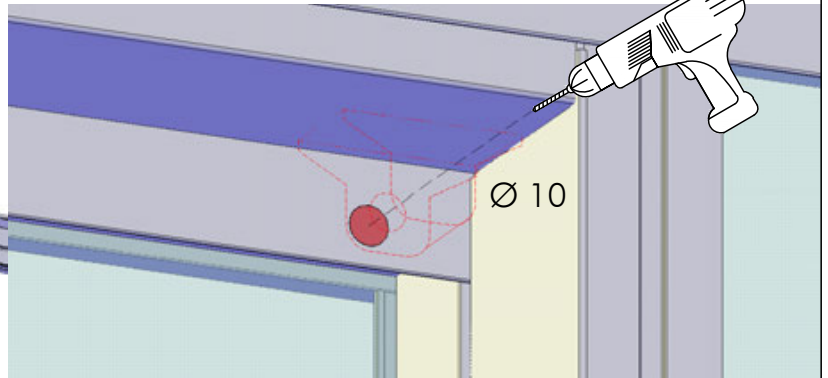
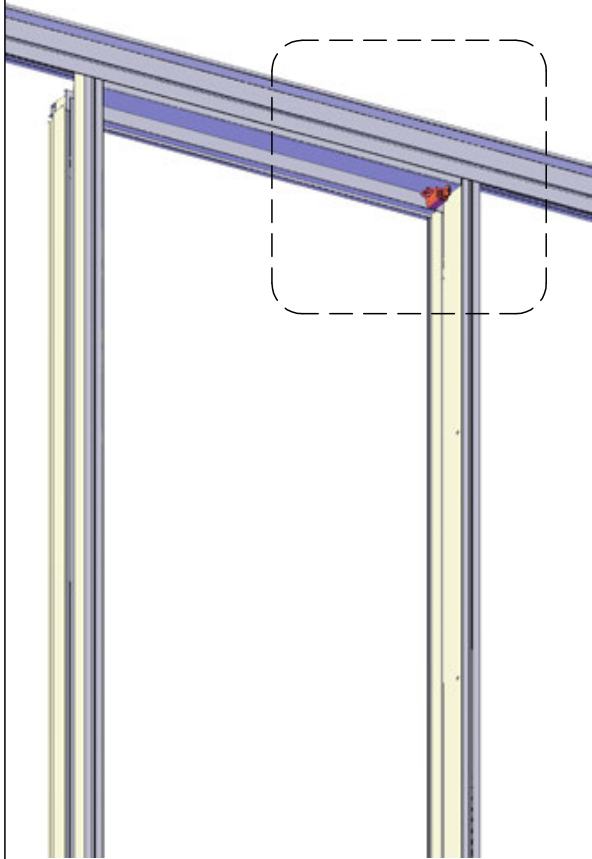
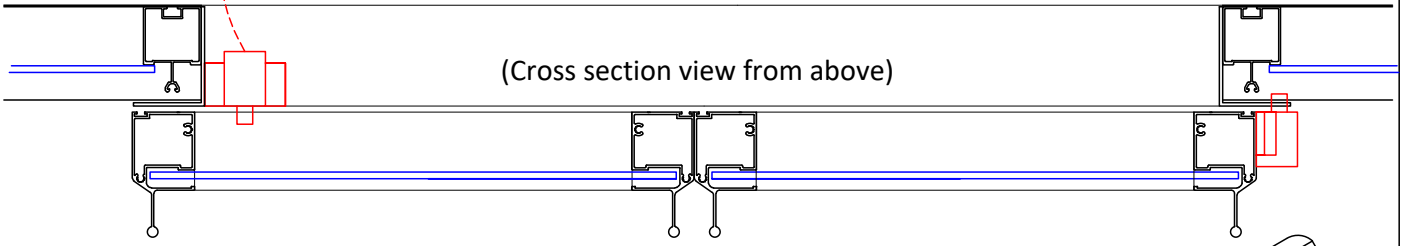

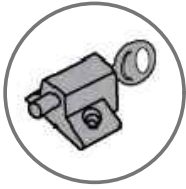

Optional Upgrade: Lock installation with Low Threshold Kit (Double Sliding Door - installed on the exterior for other door)

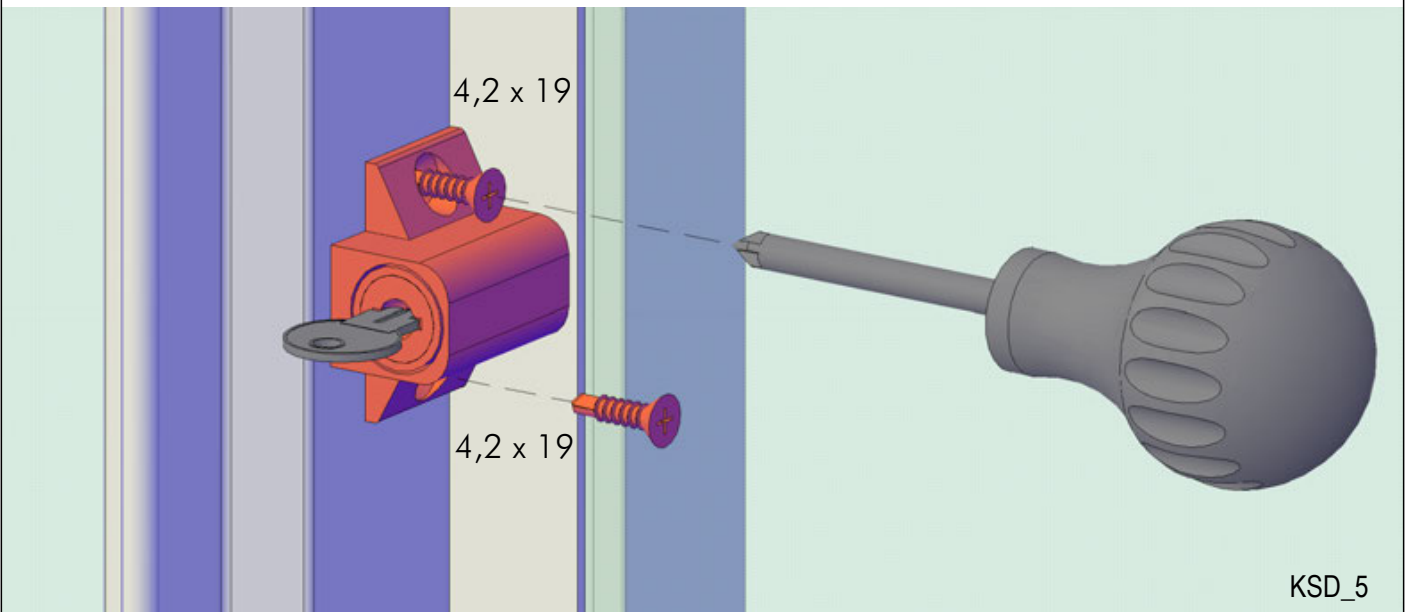
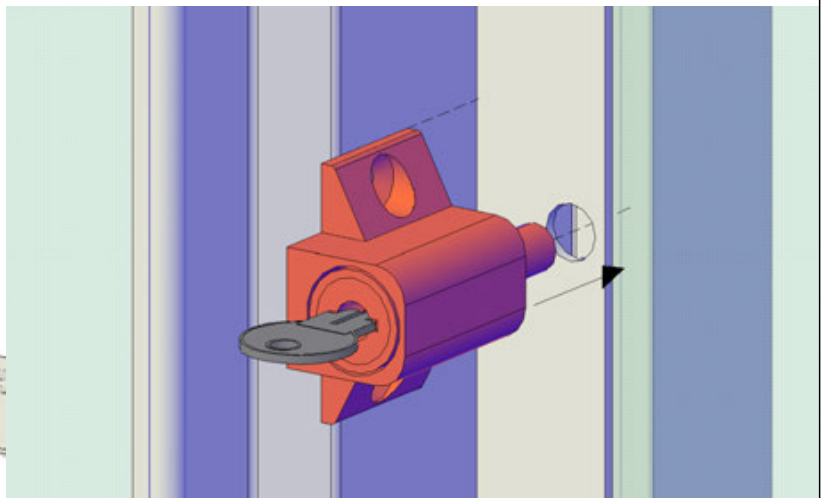
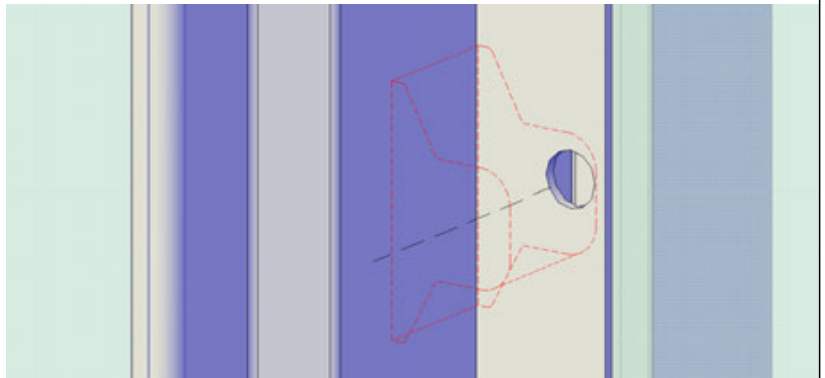
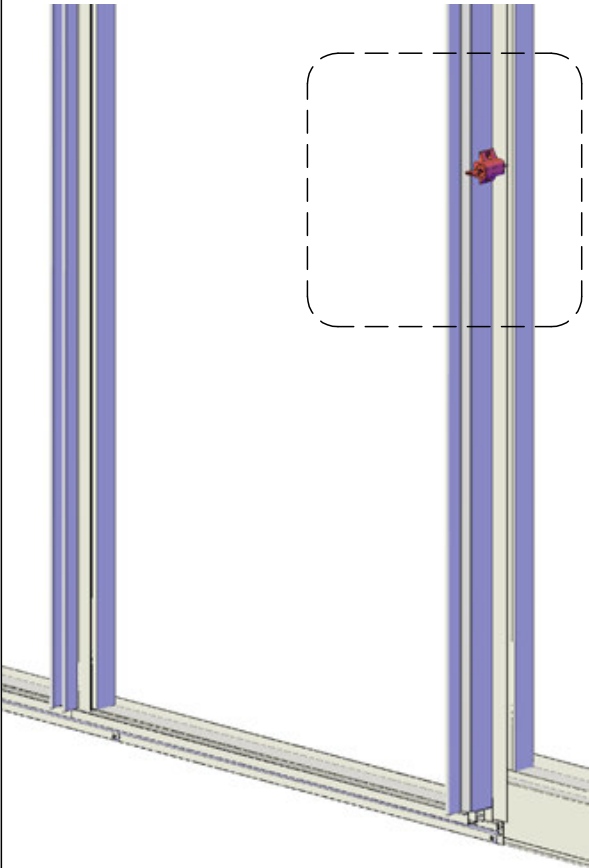
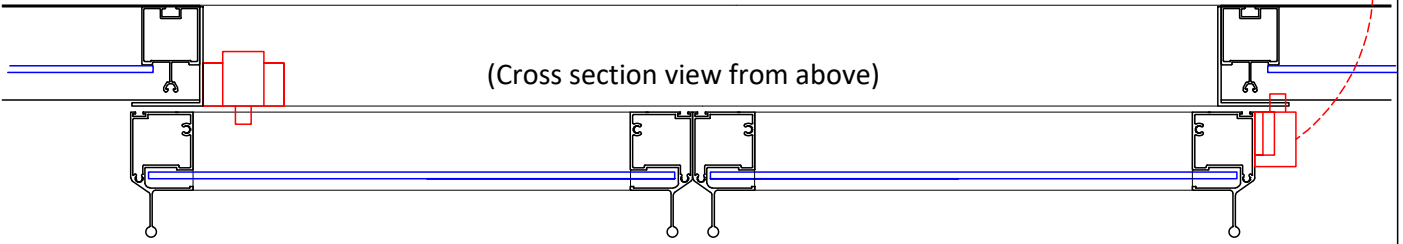
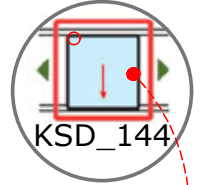

KSD_5

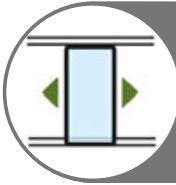

Sliding Door (Standard for most models). VI36 and 46 come with a double sliding door. Additional doors may be added to your greenhouse.

SD

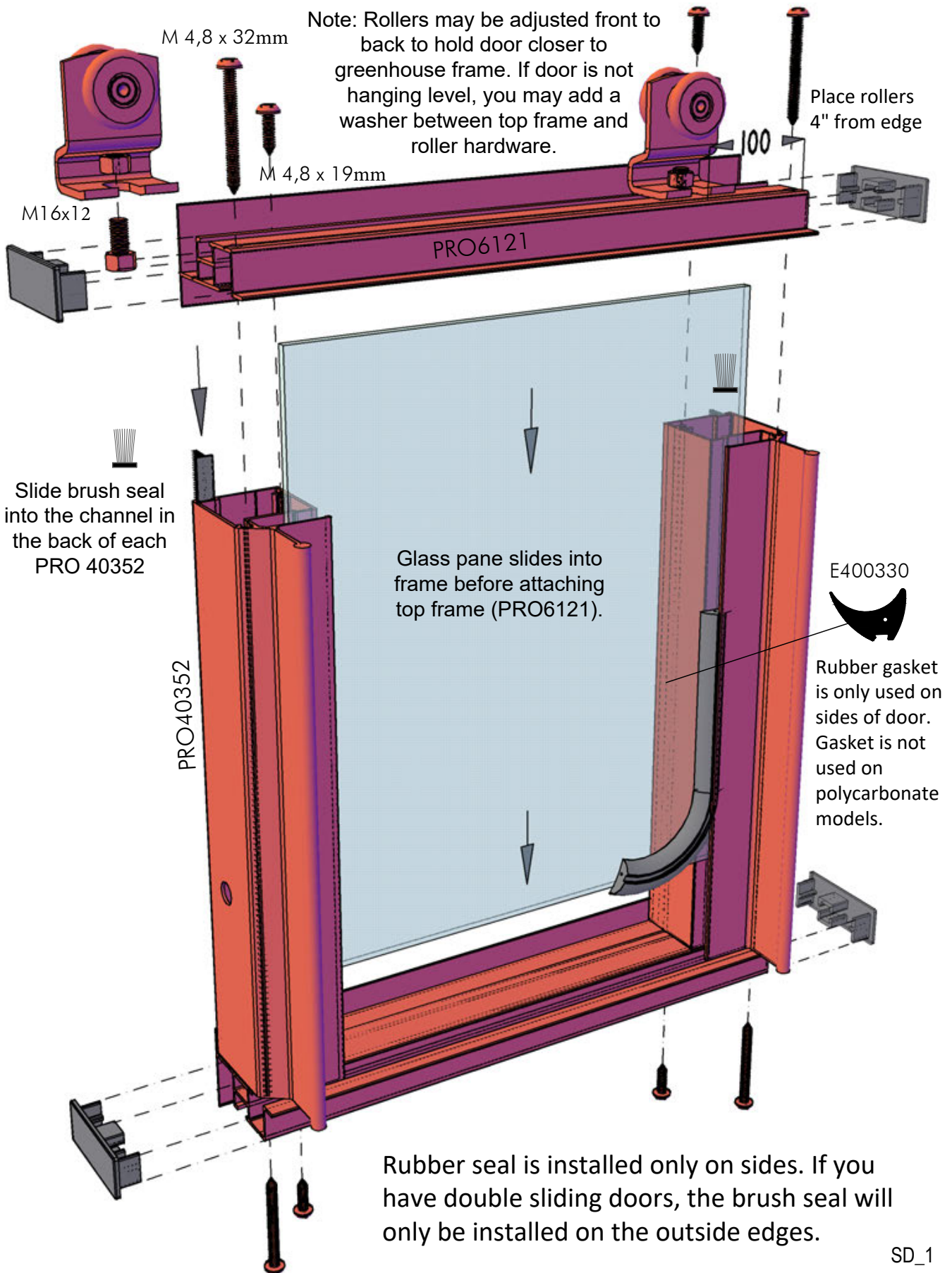

SD_1

Sliding Door: Sliding door/s may be attached in any bay (with exceptions to corner placement)

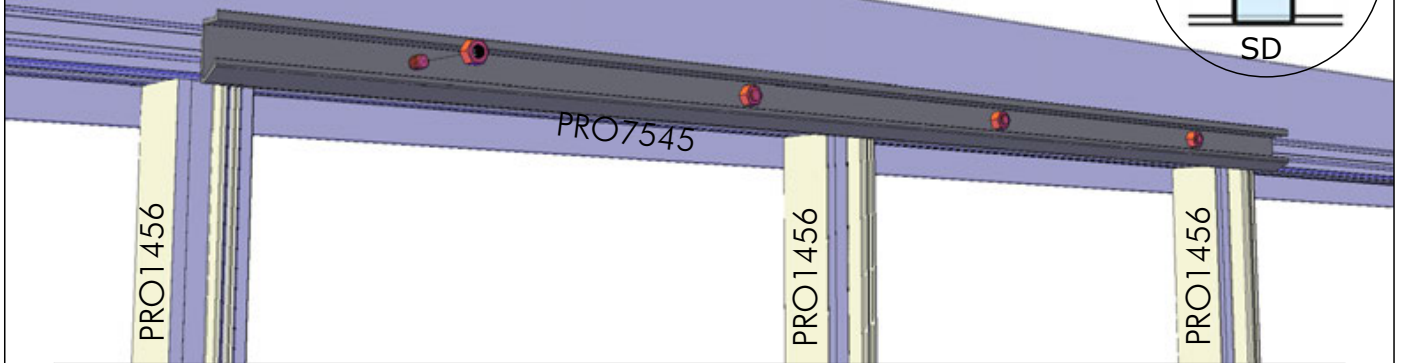
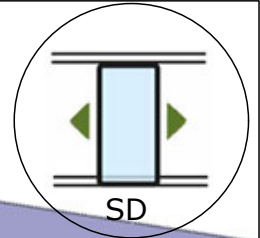

IMPORTANT for Double Sliding Door Opening!! Cut one PRO7545 in half. Place long PRO7545 in center (to support double opening) and the half PRO7545 on either side. Do not cut PRO7545 if you have a stem wall (See p. 19).

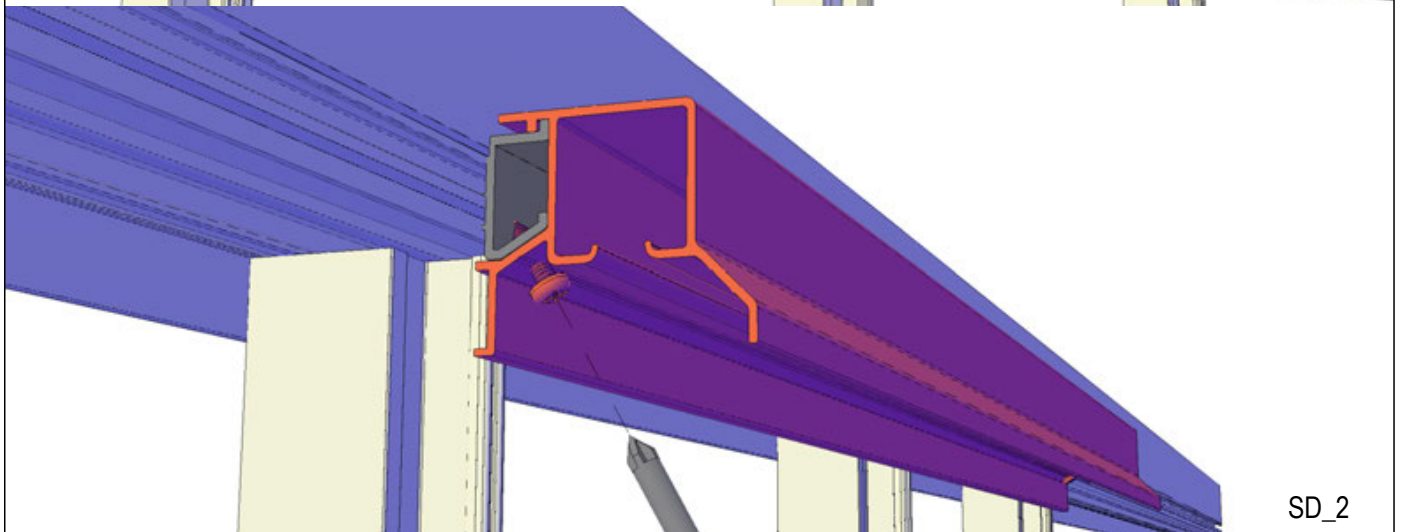
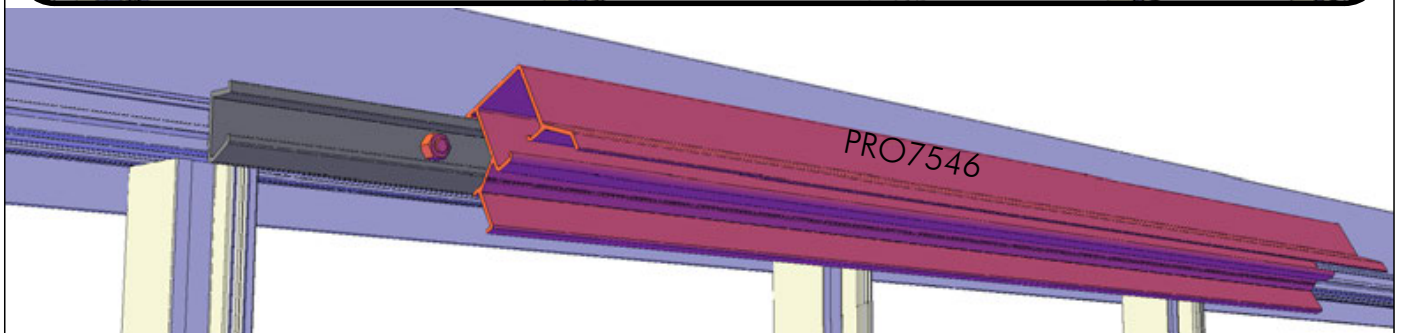
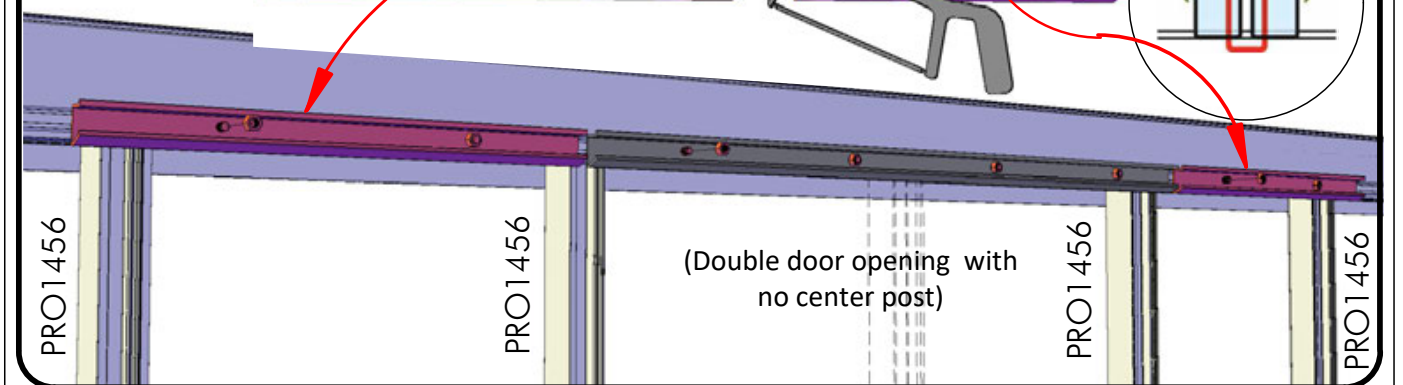
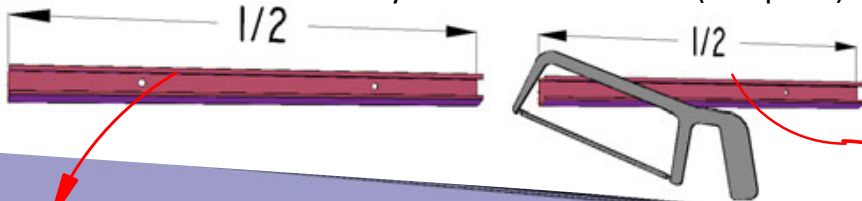

SD_2

OPTION: Double Sliding Door

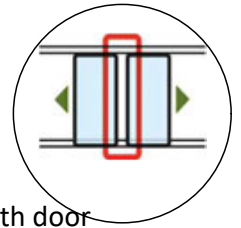

As needed, use washer underneath door hanger to level the door/s .

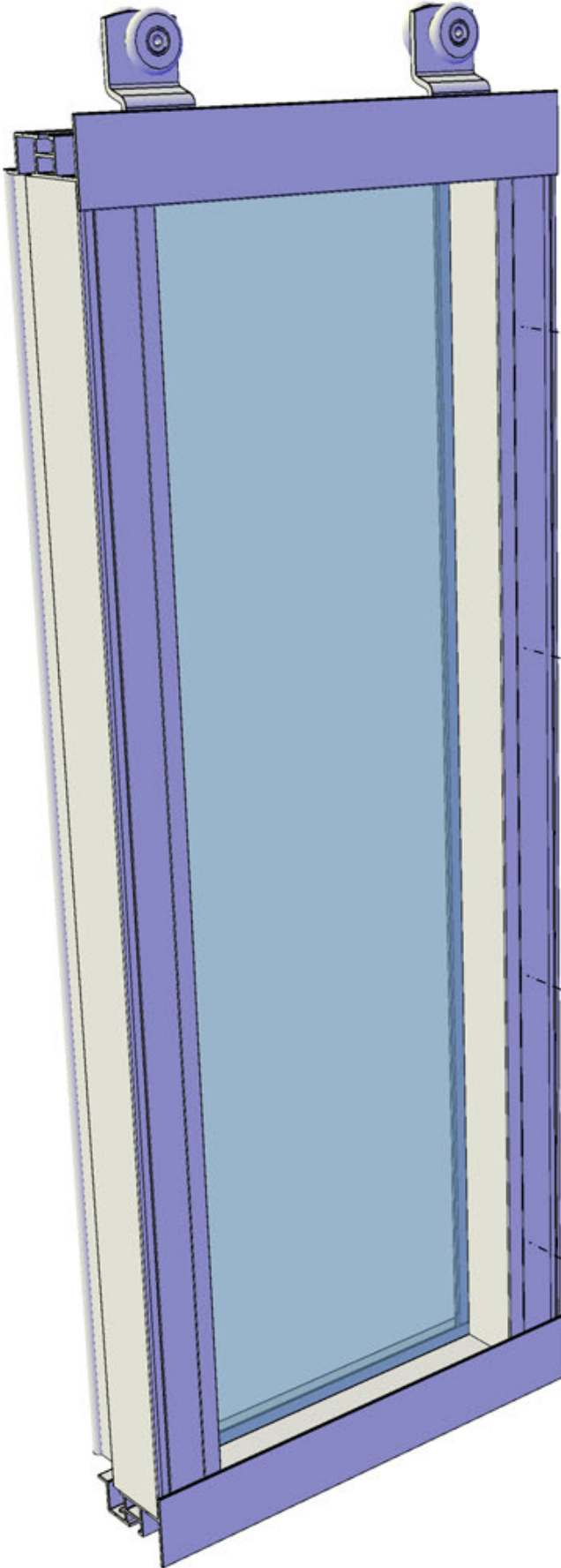

If you have a double sliding door, you will have a long L bracket that will attach to close any gap between the two doors.

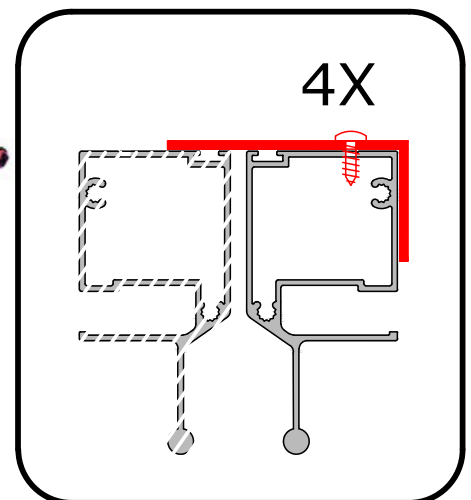

Slide door rollers into top door hanger (PRO7546 or PRO7876) and slide a stopper on either side. Determine how far the door should slide, then tighten the screw on the bottom of the stopper to secure. Finish with door hanger caps.

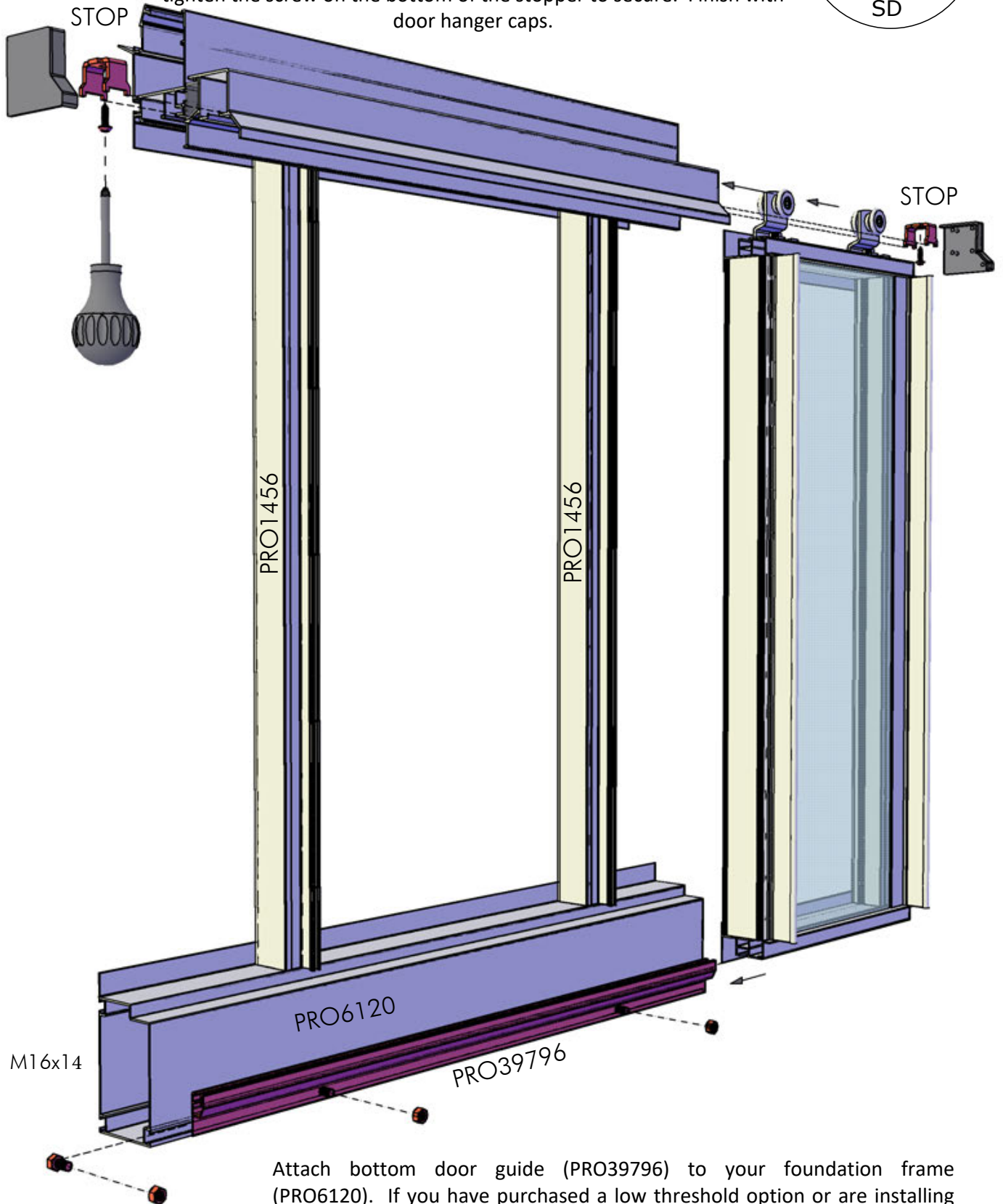
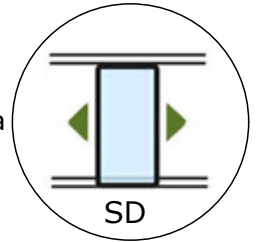

Attach bottom door guide (PRO39796) to your foundation frame (PRO6120). If you have purchased a low threshold option or are installing your greenhouse on a wall, please refer to the following pages marked SD_MUR for stem wall and KSD for low threshold kit before installing door, bottom door guide, and locks.

Sliding Door Lock (w/o low threshold kit)



Install lock at bottom of a:
- single sliding door
- first door of double sliding doors
- both of your double sliding doors

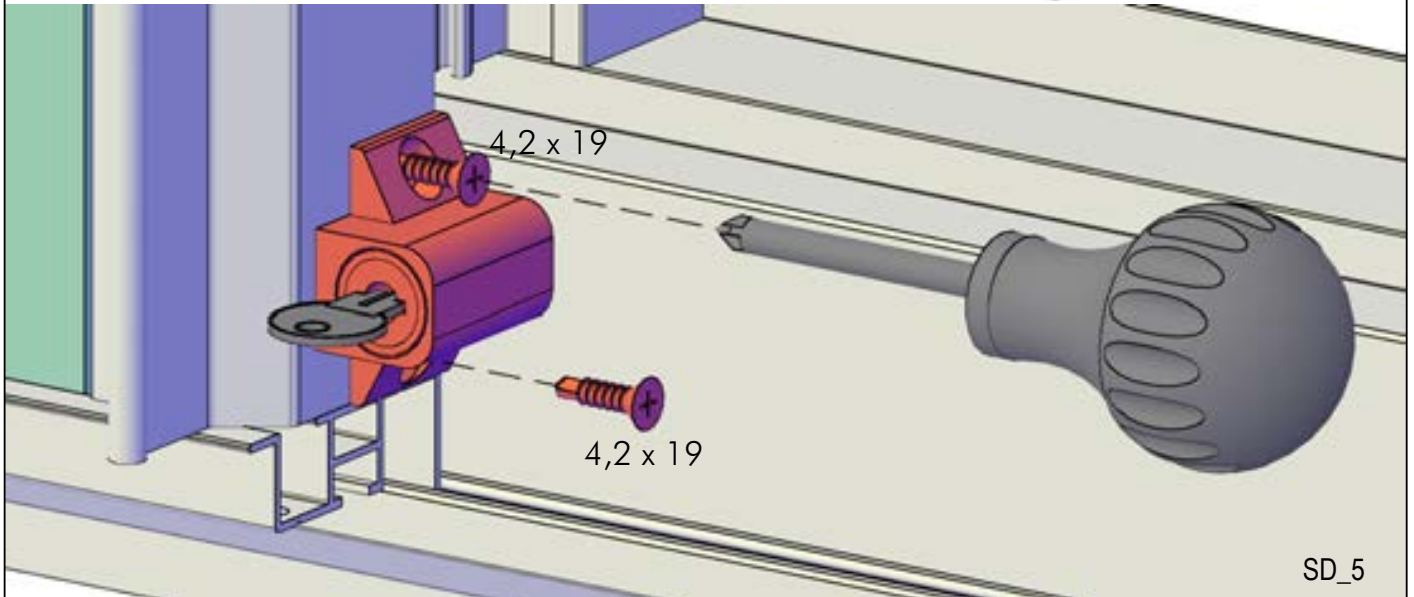
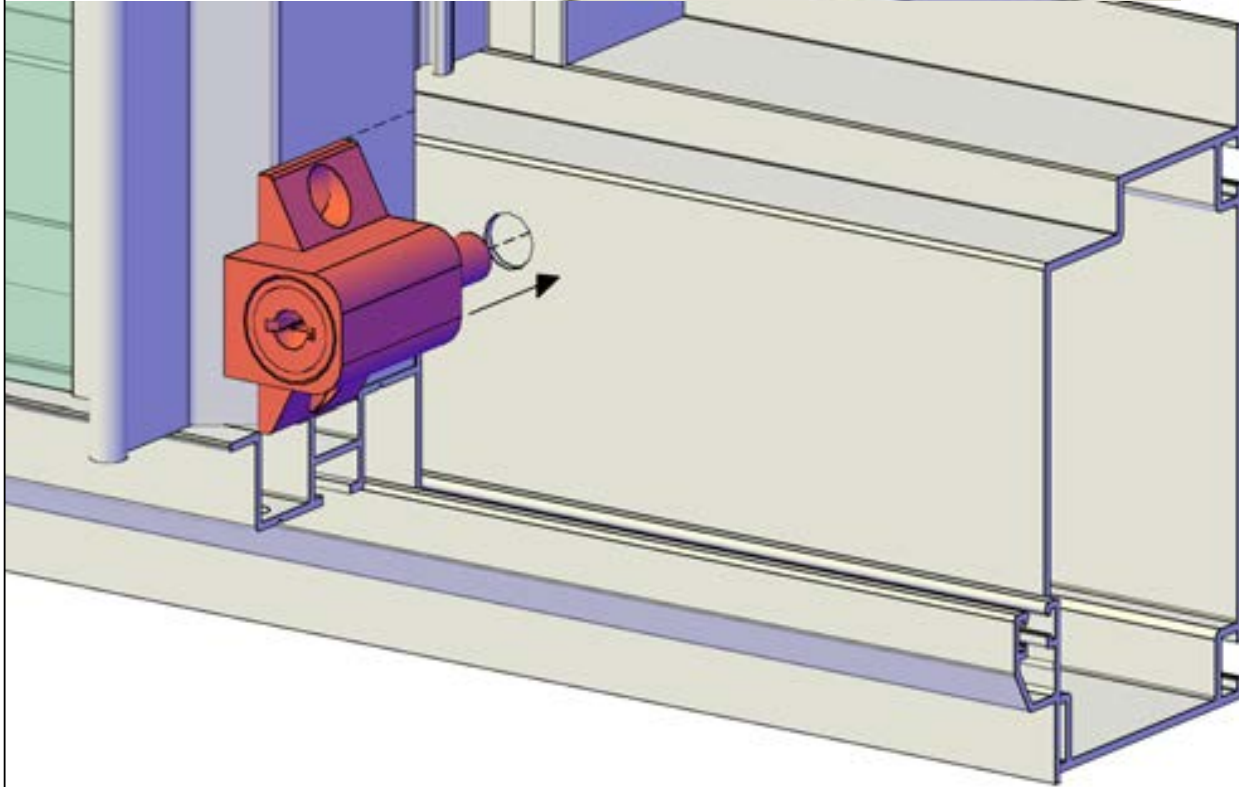
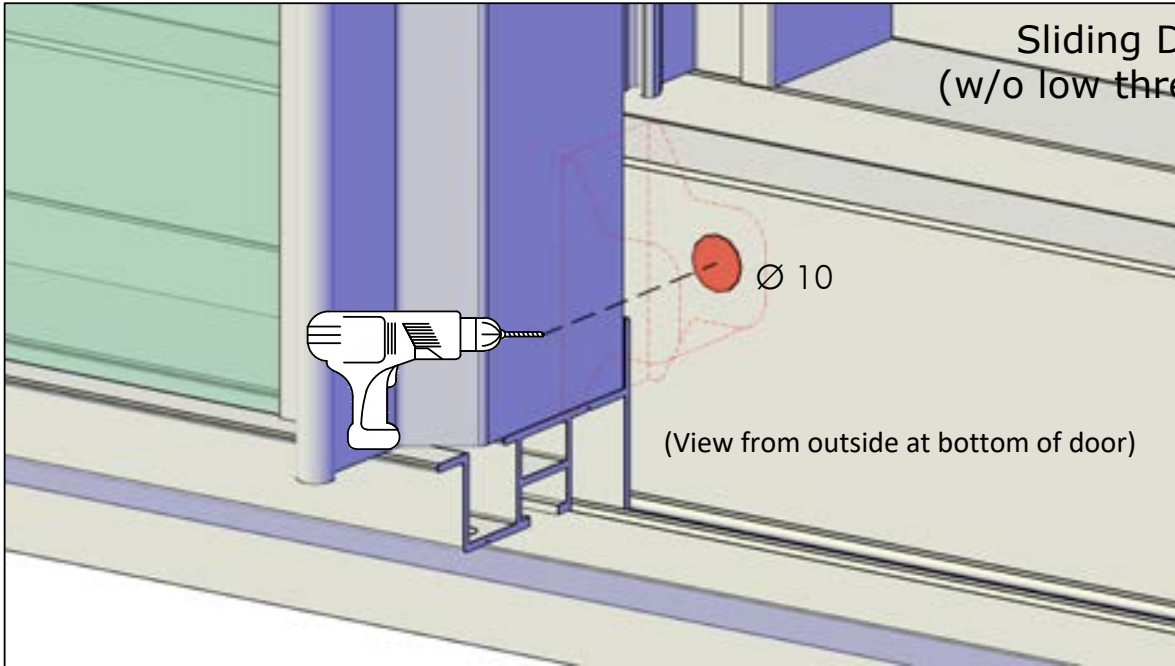

SD_5

(View from inside at top of door)

Double Sliding Door Lock (w/o low threshold kit)

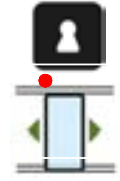

If you have a double sliding door, you may install one lock on the inside of your greenhouse as shown

Ø 10

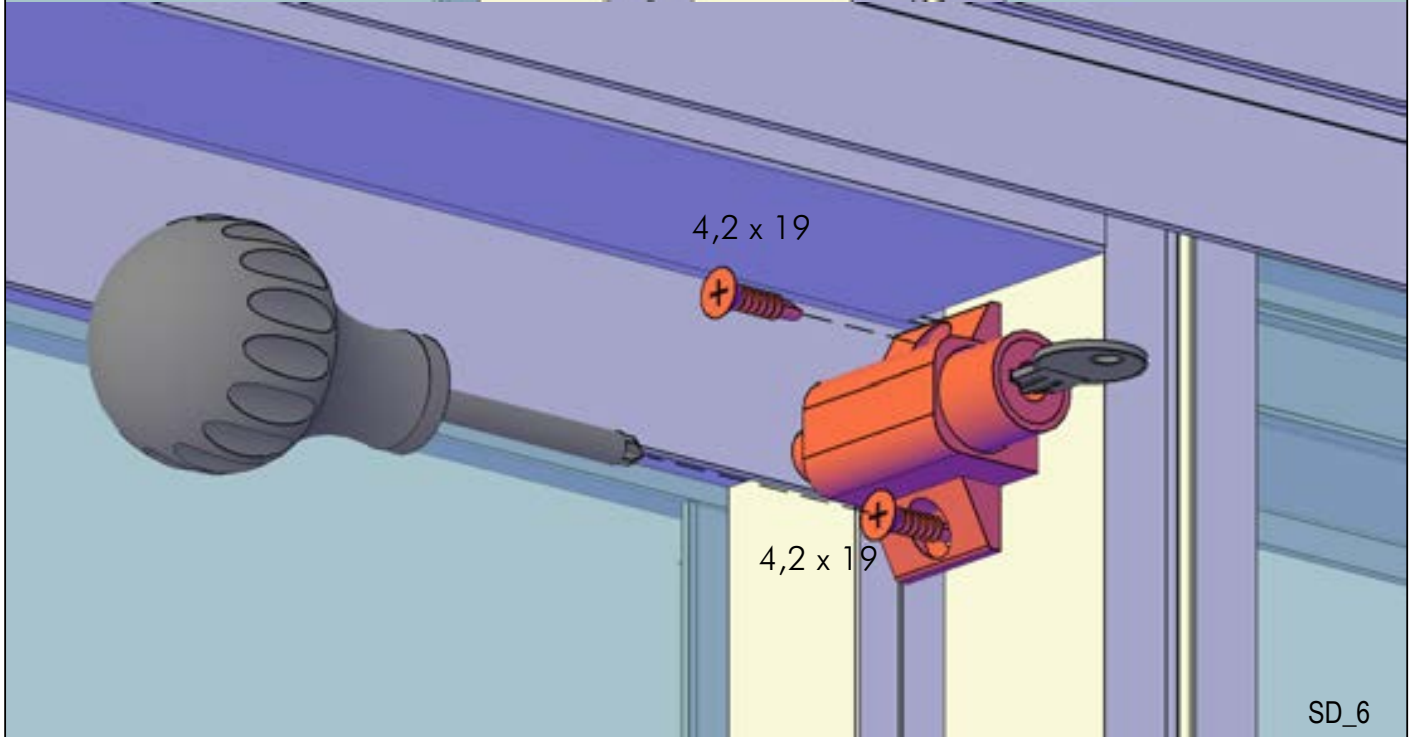
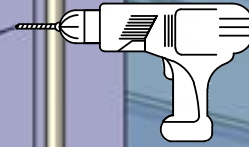

4,2 x 19

4,2 x 19

SD_6

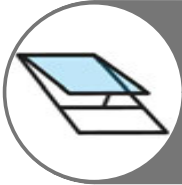

Roof Window /Vent -

all hardware will be included in roof vent package - including crossbar to frame opening

RW

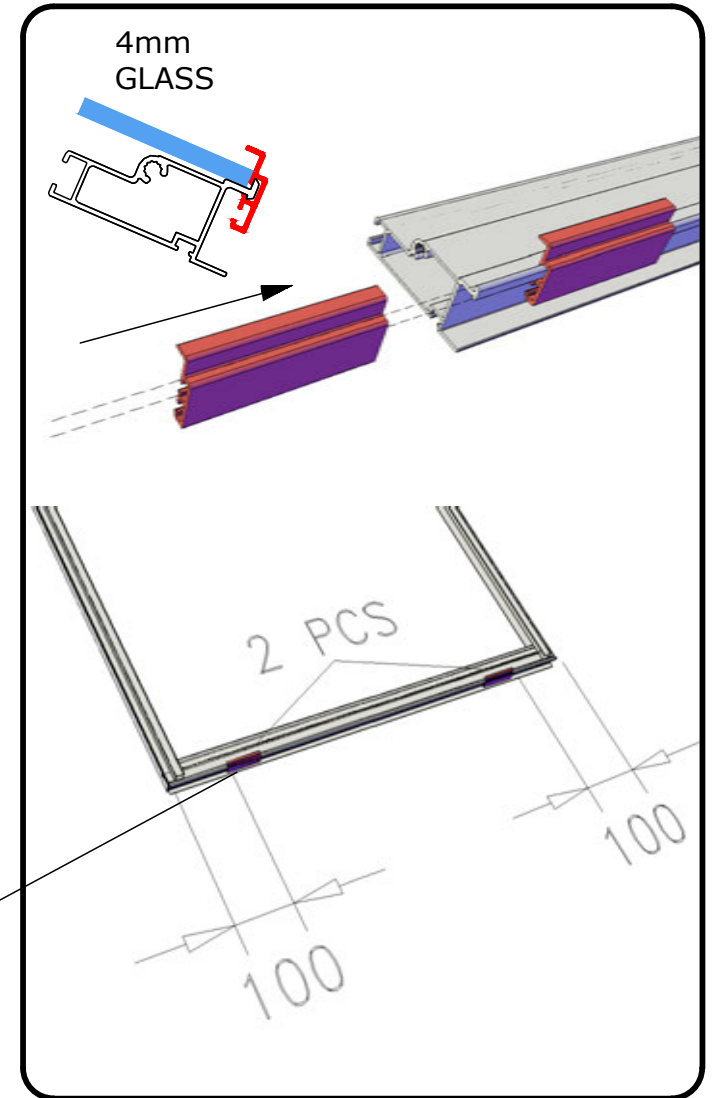
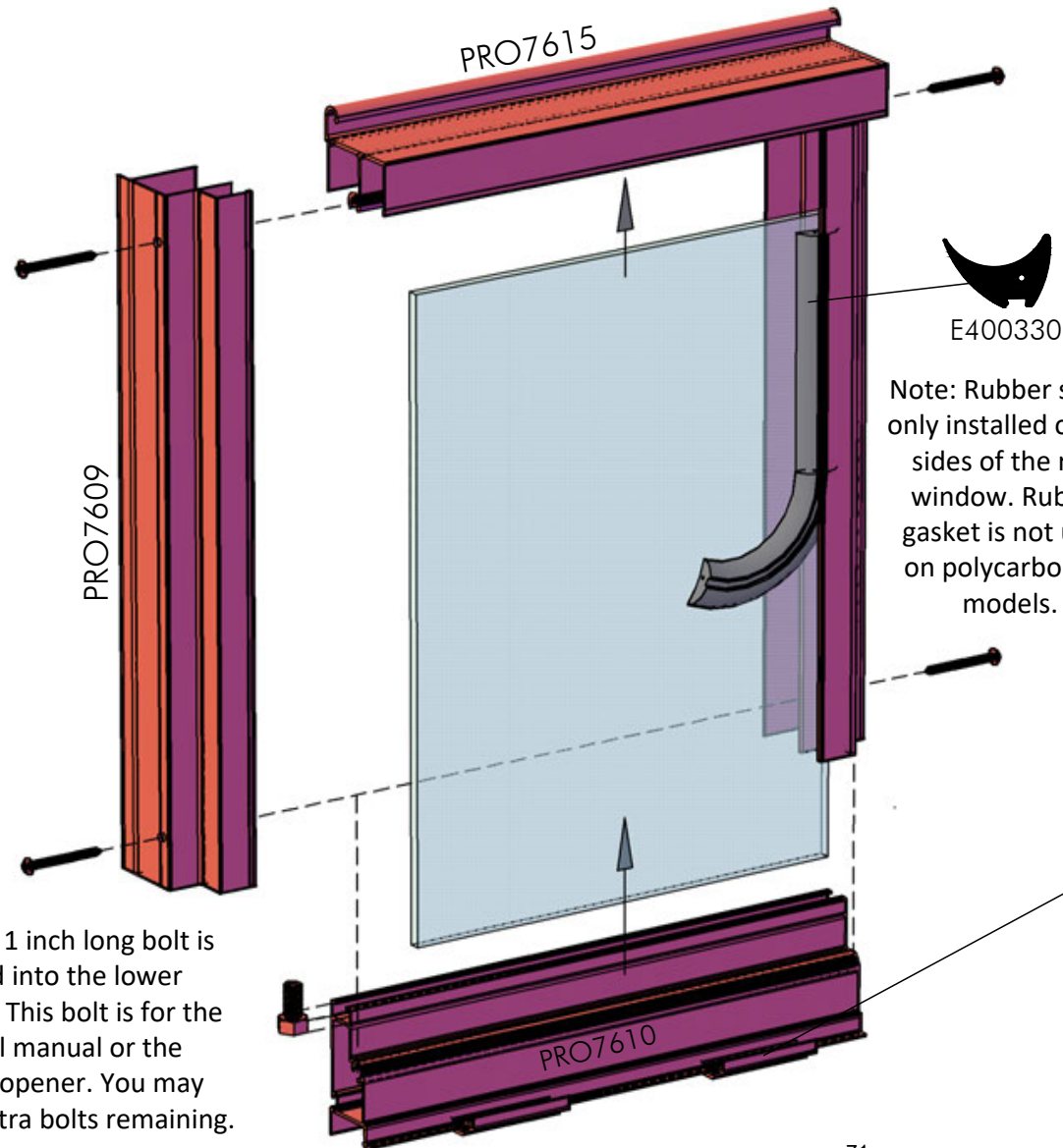

Roof Window Installation

Note: Inserting a bolt/nut on both sides of the roof window will prevent it from moving side to side once it is in place.

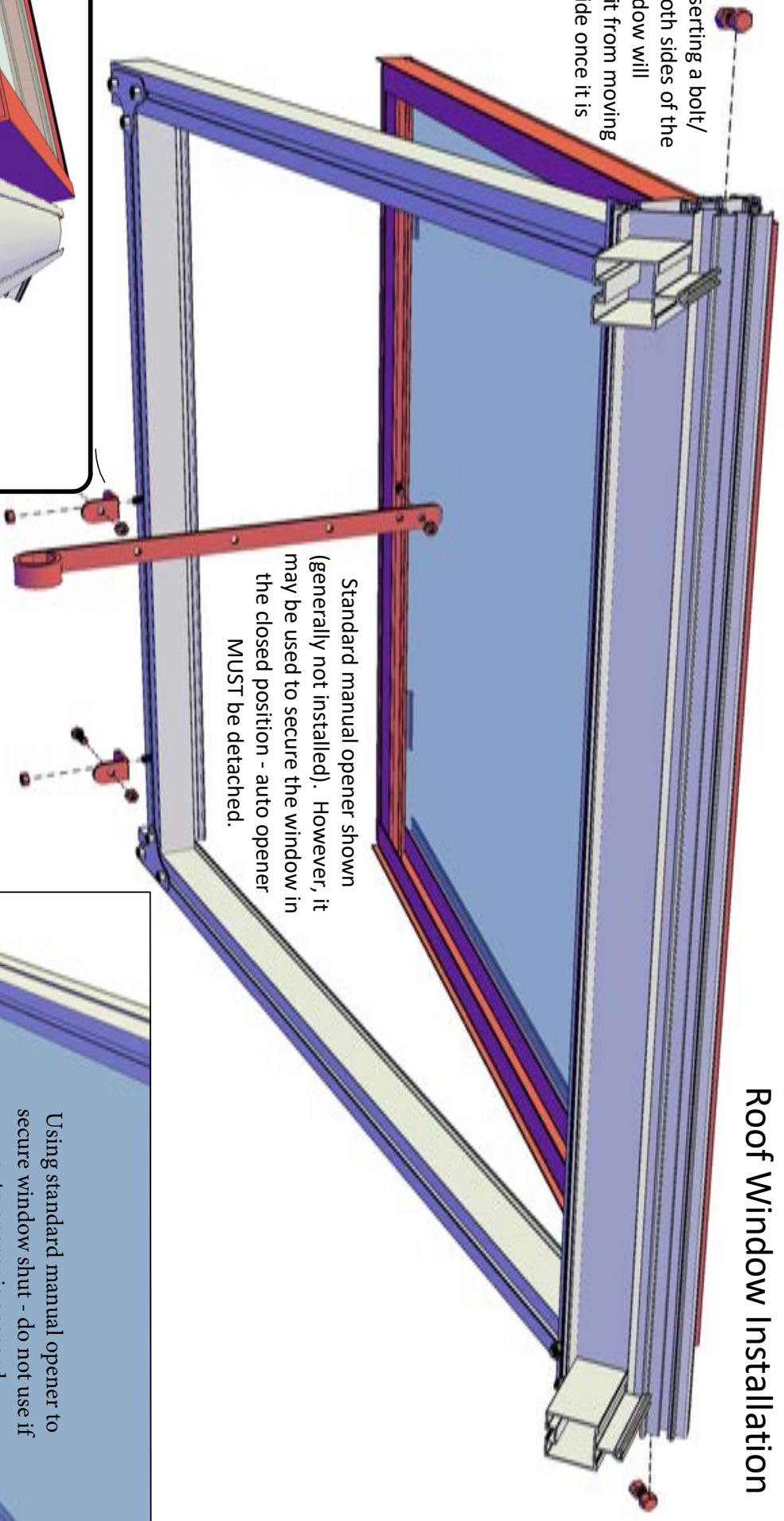

Standard manual opener shown (generally not installed). However, it may be used to secure the window in the closed position - auto opener **MUST** be detached.

TO INSTALL: Slide window into the ridge beam from either end of the greenhouse. The "hook" on the top of the roof window profile will slide into the channel of the ridge beam (shown to the left).

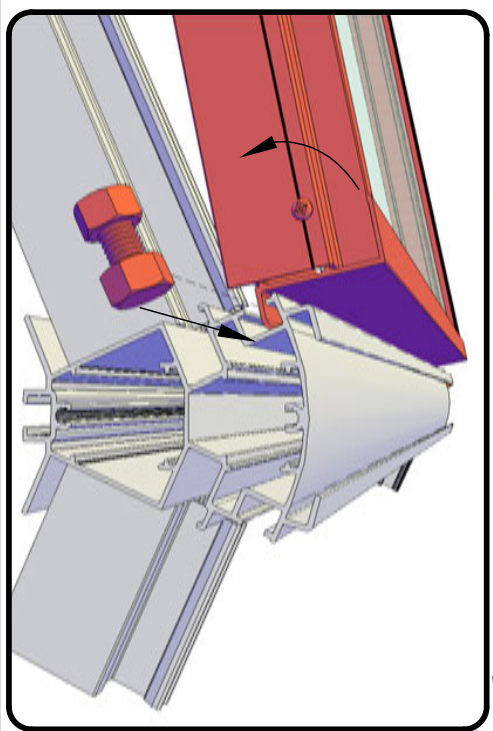

Using standard manual opener to secure window shut - do not use if auto opener is engaged.

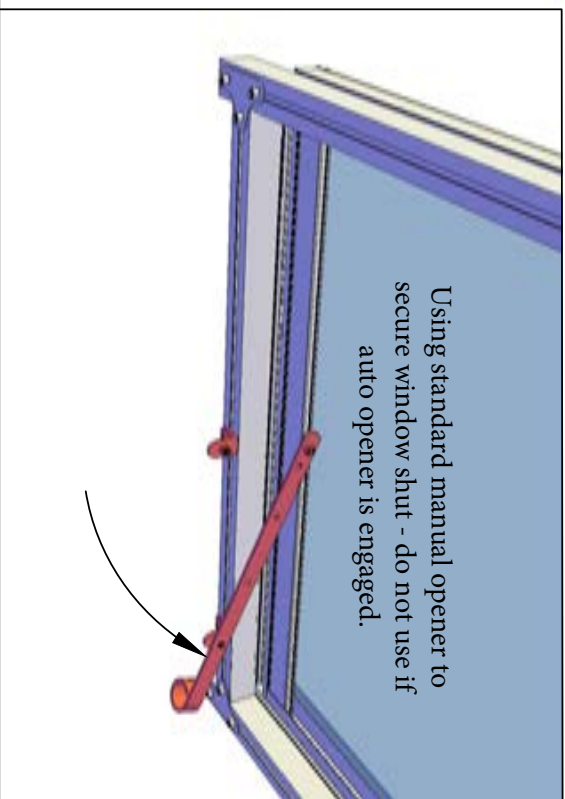

OPTION: Auto Opener (Ventomax)

IMPORTANT! Read installation instructions included in your Ventomax auto opener box to ensure proper installation. There is also information to fully understand the functioning and maintenance of these unique openers.

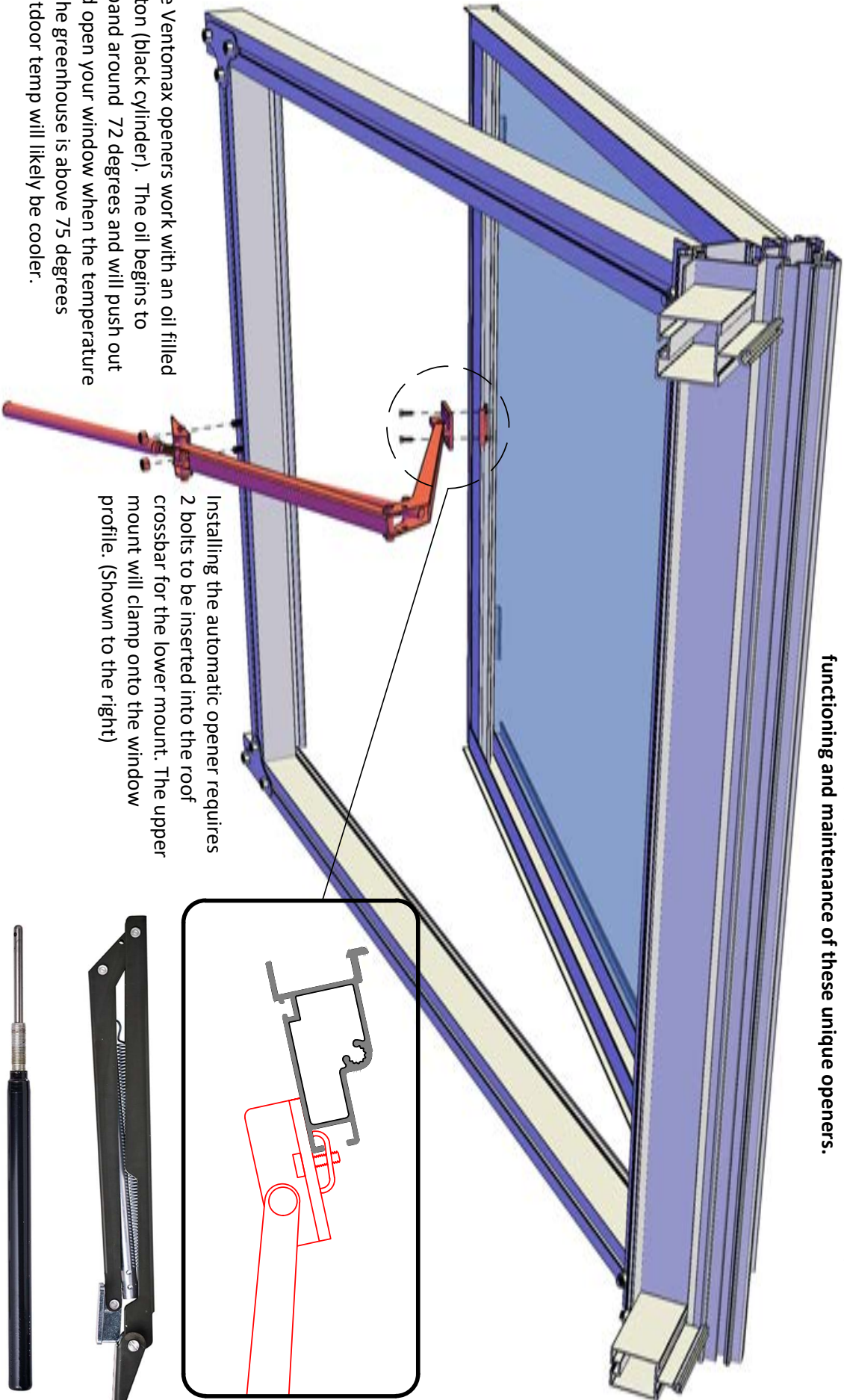

The Ventomax openers work with an oil filled piston (black cylinder). The oil begins to expand around 72 degrees and will push out and open your window when the temperature in the greenhouse is above 75 degrees (outdoor temp will likely be cooler).

Installing the automatic opener requires 2 bolts to be inserted into the roof crossbar for the lower mount. The upper mount will clamp onto the window profile. (Shown to the right)

If you are struggling to install your piston and it is above 70 degrees, place the piston in cold water/fridge for 10 minutes so the rod can retract. Oil piston rod 2-3 times/year with a light oil such as WD40 or even olive oil.

OPTION: Spindle Manual Opener

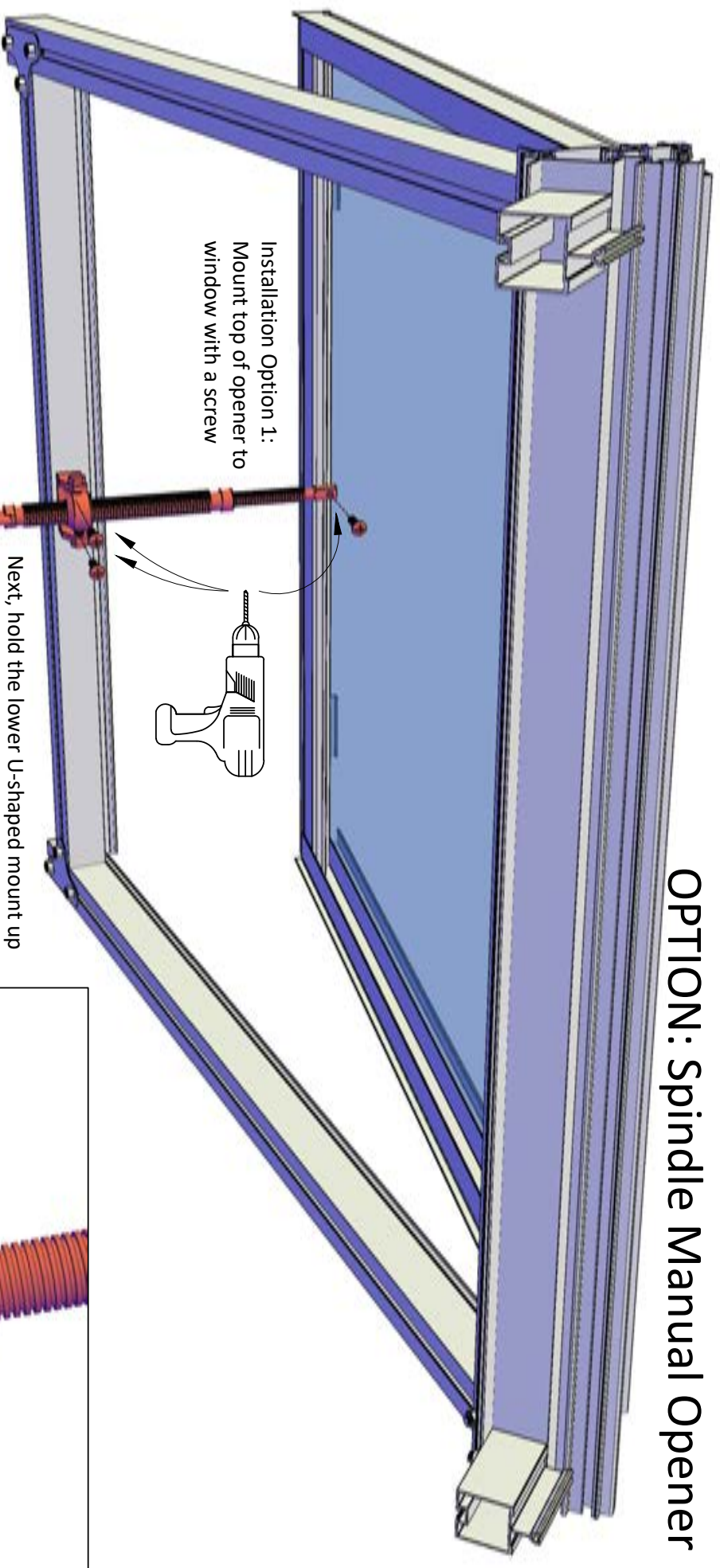

Installation Option 1:
Mount top of opener to
window with a screw

Installation Option 2: Insert a 1 inch long bolt into
lower roof window channel. Slide to the center and
lock it in place with a nut as shown below.

Next, hold the lower U-shaped mount up
to the crossbar and mark the center of one
hole. Using a 1/8" drill bit, drill the first
hole, then screw the bracket on, check for
level - then mark and drill the second hole.
Slide the brass part of the opener over the
bolt in the window channel. Use the
supplied nylock nut to secure the opener
on the top mounting bolt. Finally thread
the large side bolts into the U-shaped
mount and the opener is installed.

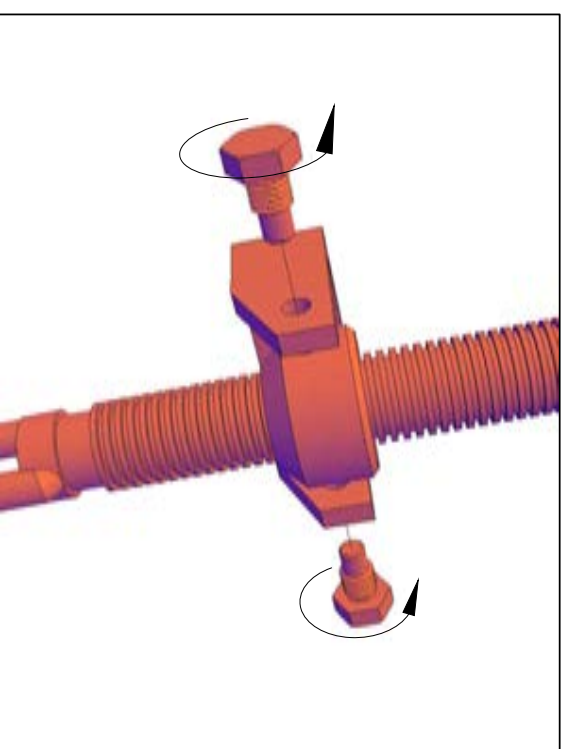



OPTIONAL UPGRADE: Fly screen for roof vent

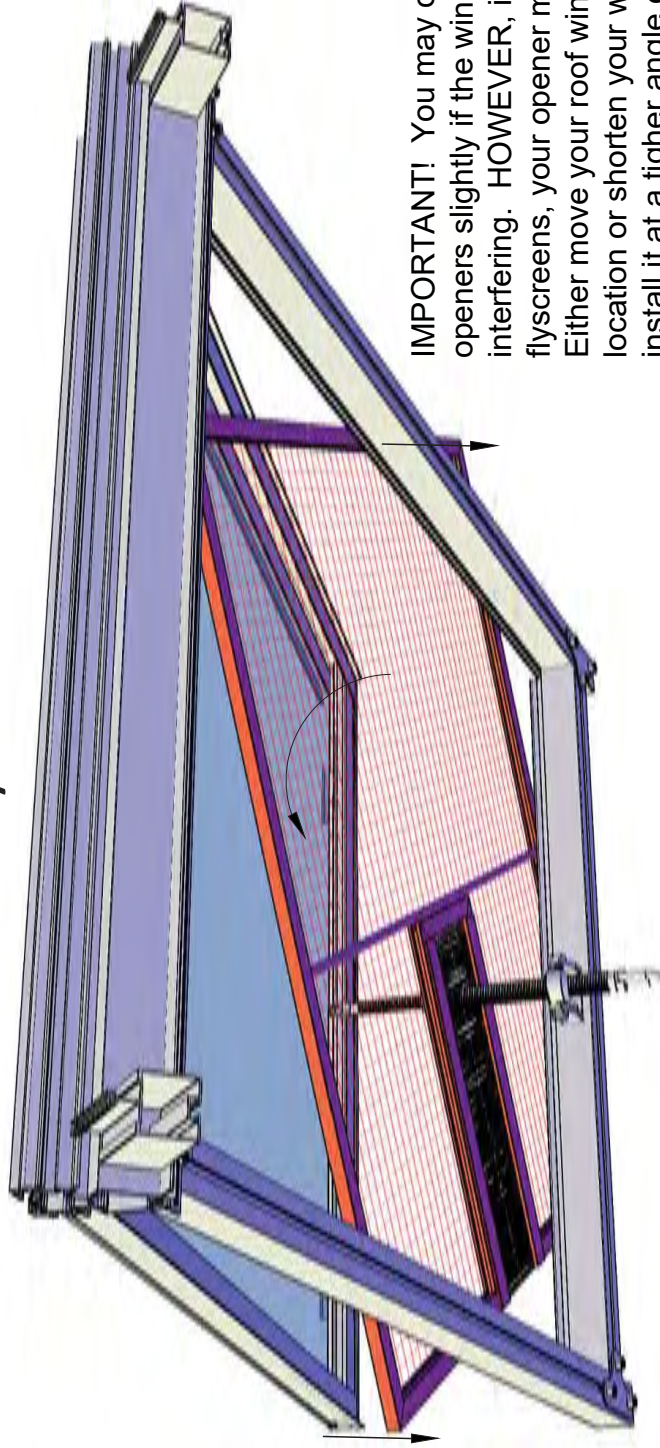

IMPORTANT! You may offset your auto openers slightly if the wind braces are interfering. **HOWEVER**, if you have purchased flyscreens, your opener must be centered. Either move your roof window to a different location or shorten your wind strap slightly to install it at a tighter angle on the gutter flange.

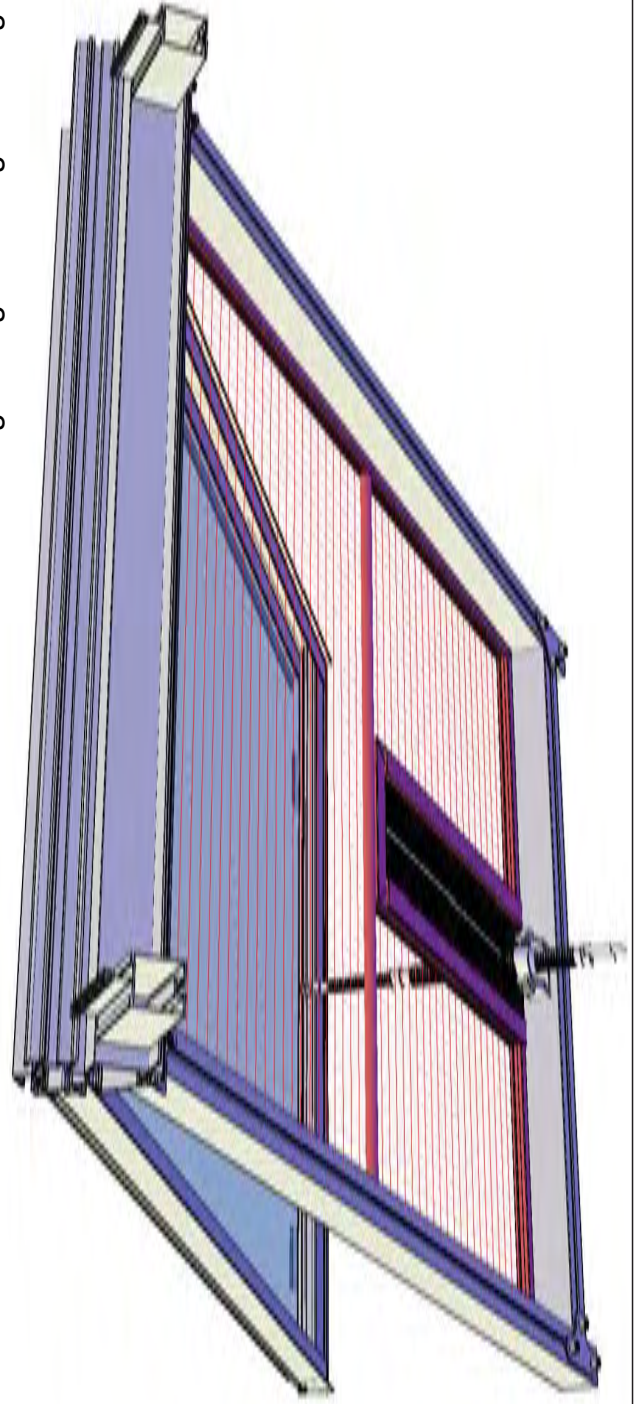



Louvre Window - All Standard Royal models include one louvred window

LV

Note: All louvred window are black (even with green models)

Numbers below refer to steps in the following pages



It is likely that your kit include an automatic opener (SESAM LIBERTY) for the louvre vent. Please refer to the Installation and Care manual packaged with the Sesam Liberty opener. You will need to remove the manual opener following the directions.

Piston maintenance: apply a light oil (WD40 or olive oil work) to the piston rod to keep it moving smoothly 2-3 times/year.

1

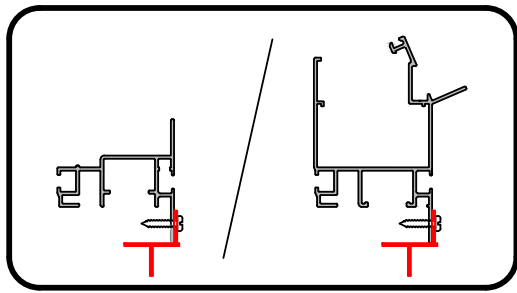

Louvre window may be installed on sidewall (under gutter profile (PRO20227)) or on gable end (under horizontal gable profile (PRO20229)). Both are shown to the left and below.

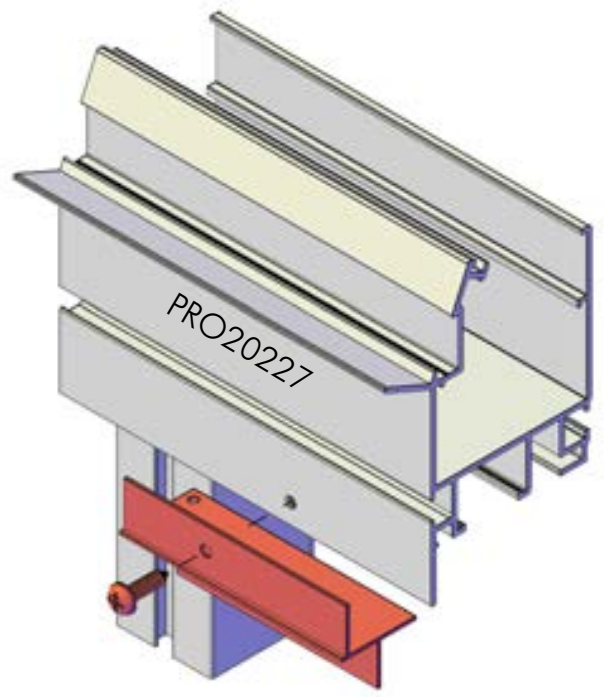
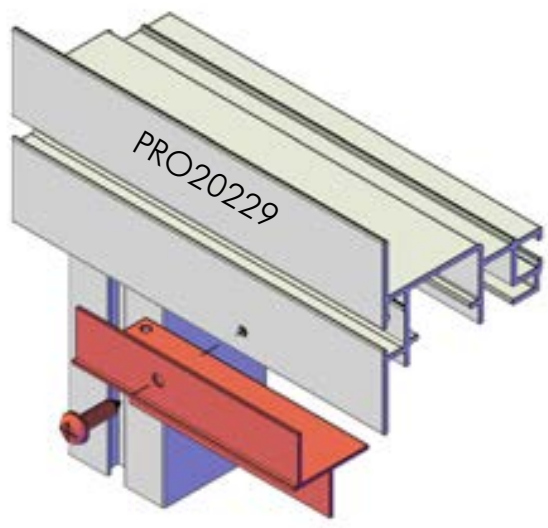

2

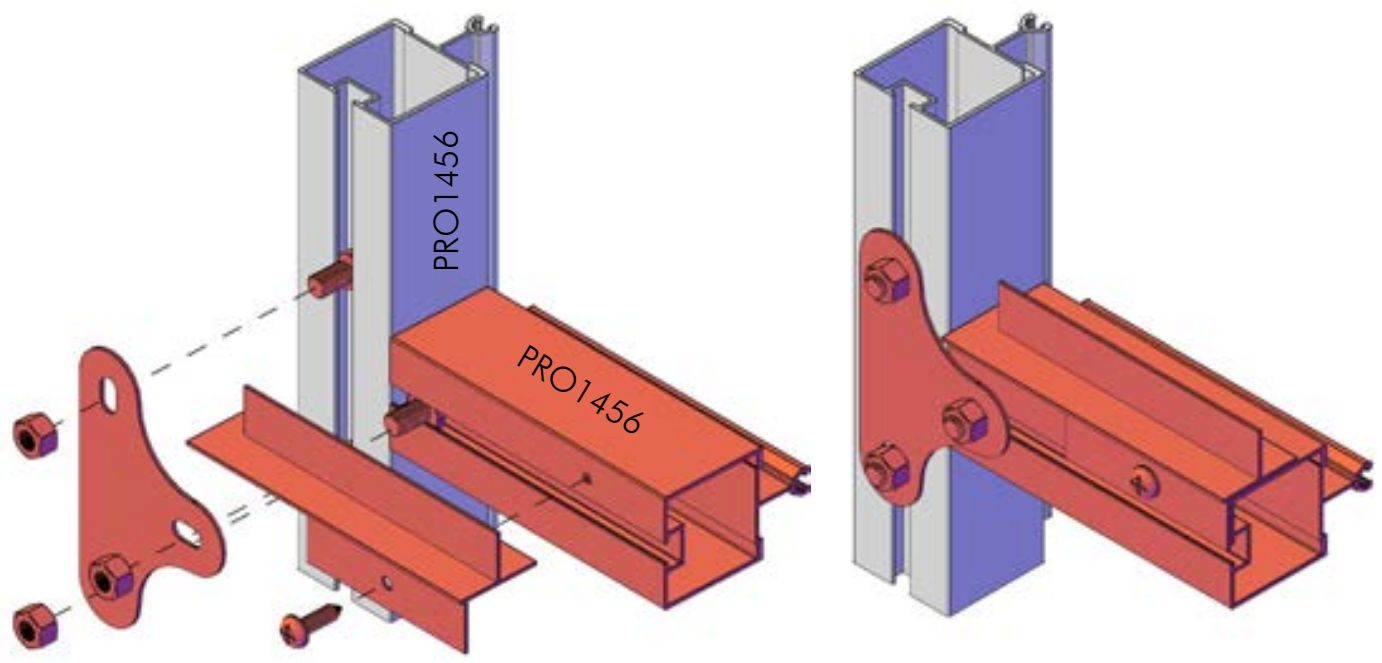

3

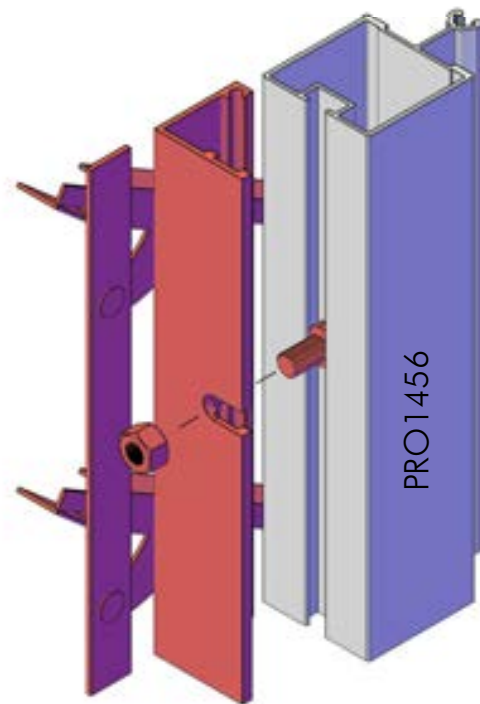

Insert a washer (not included) between black louvre frame and the greenhouse profile at all four bolt locations.

4X

4

Pinch louvre clamps together to hold glass. We recommend using a few dabs of silicone where the glass meets the clamps to hold the glass more securely. You may use the silicone that came with your red shims.

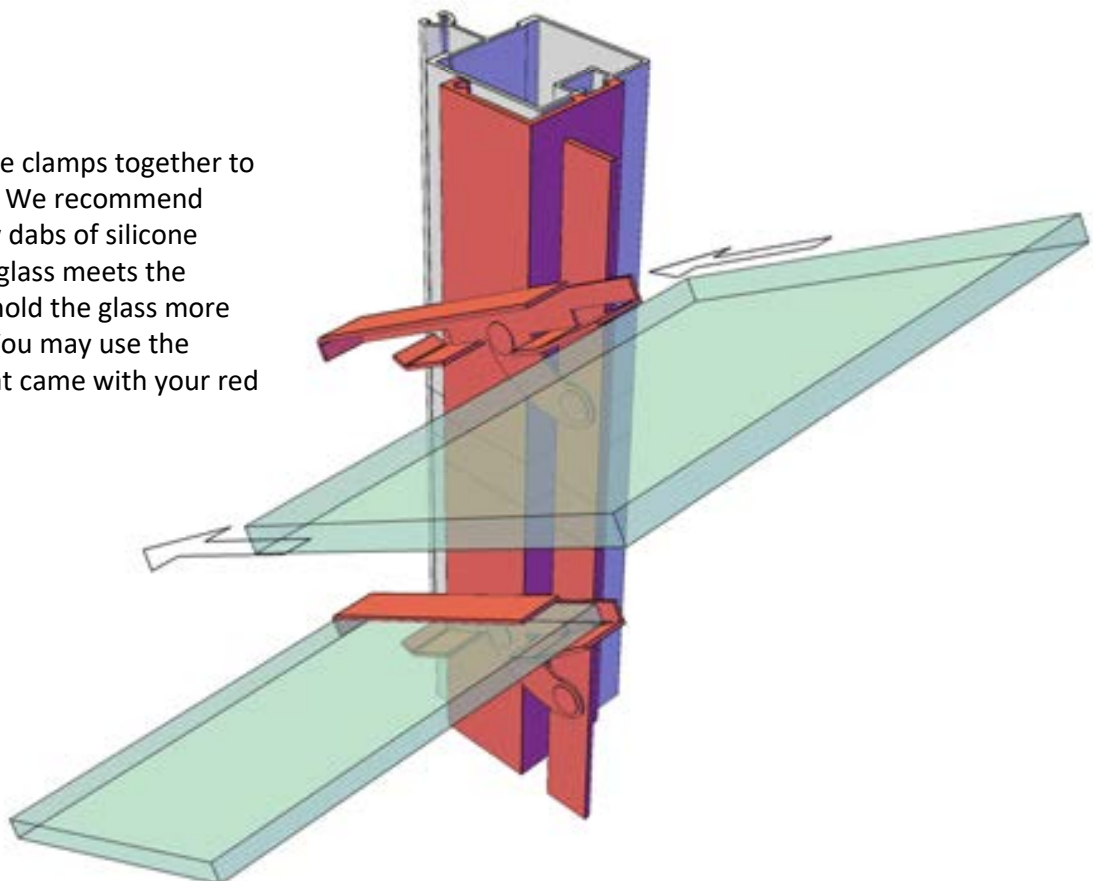

Louver Window Cover

During cold weather, the louvered window may get drafty. Your kit includes a lexan cover to seal the louvers during this time.

To install the Lexan panel:

- Unscrew the piston from your auto opener
- Go outside the greenhouse and pull back the heavy duty rubber gaskets that hold in the panes of glass to the left, right, and bottom of the louvered window (see picture to the right)
- Place the lexan panel over the louvers as though it were a pane of glass and replace all the heavy duty gaskets (see photos below)





OPTIONAL UPGRADE: Louvered Window Fly Screen

FLV

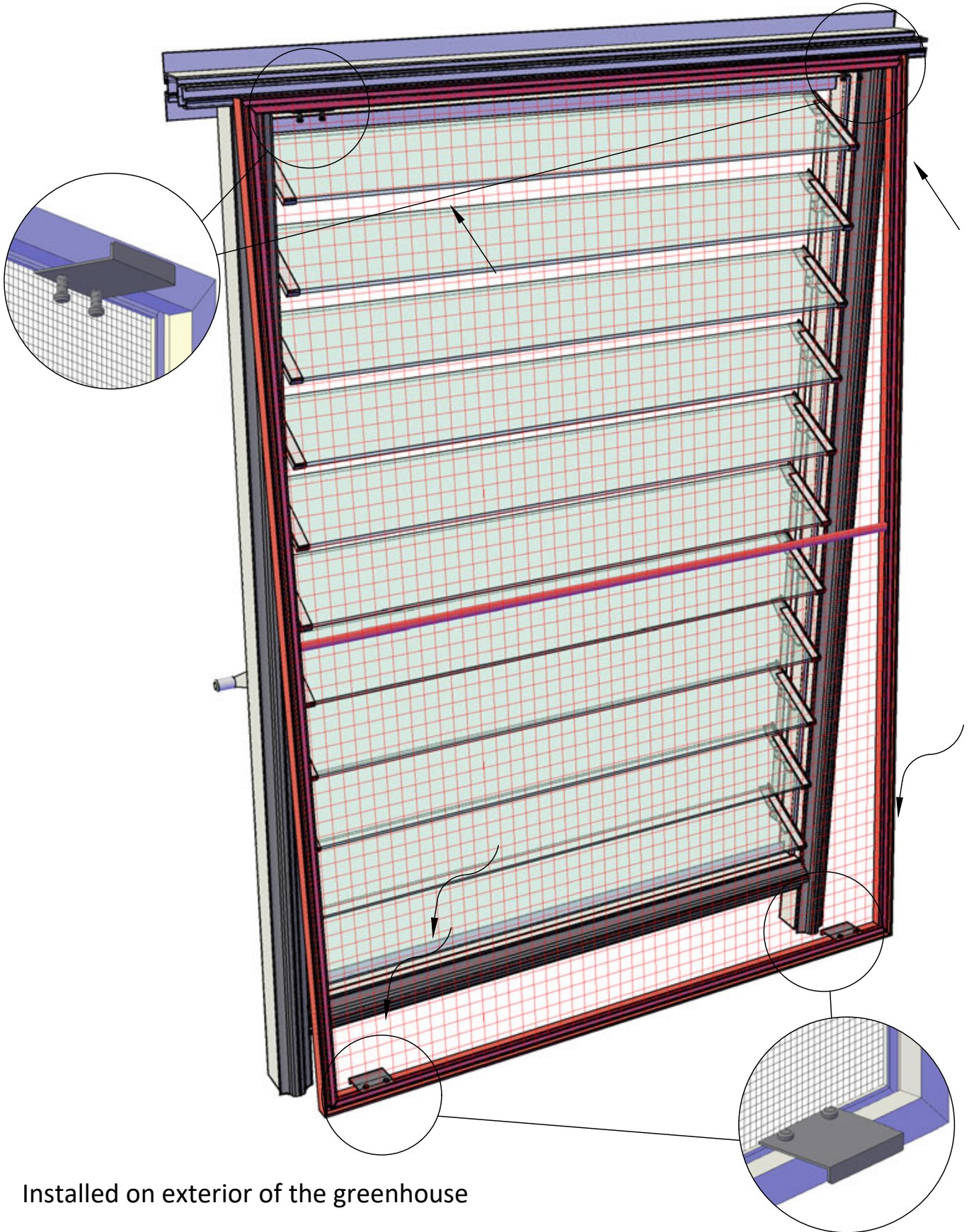

Installed on exterior of the greenhouse



OPTIONAL UPGRADE: Push out window - only Retro Victorians include this option

SW

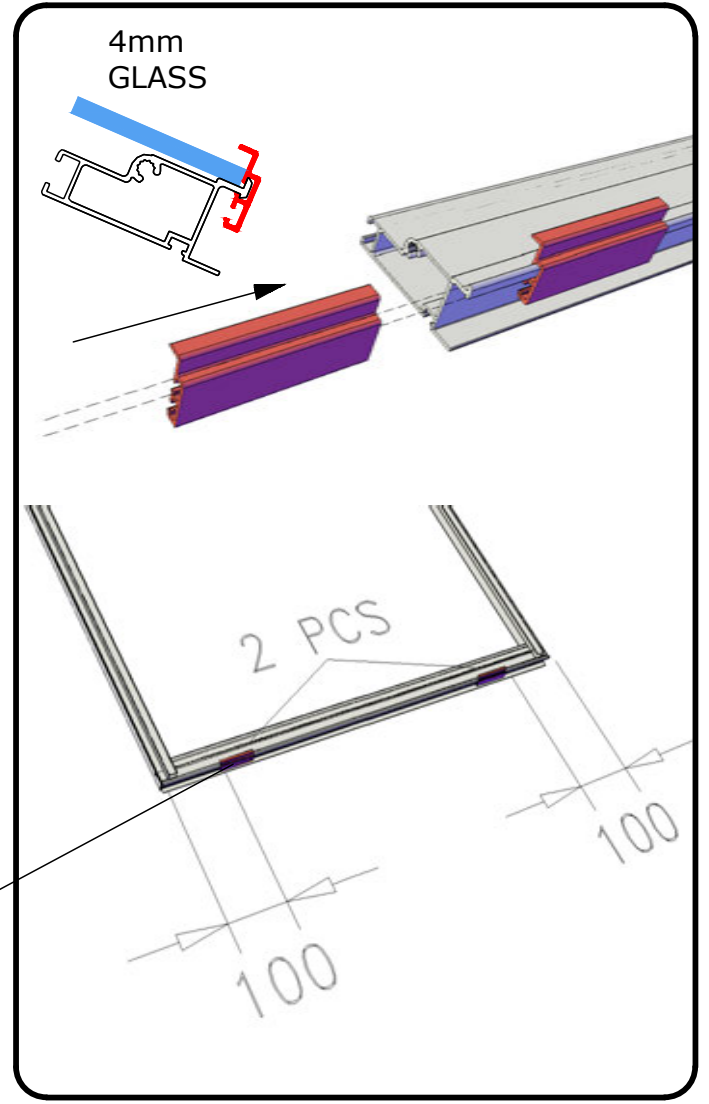
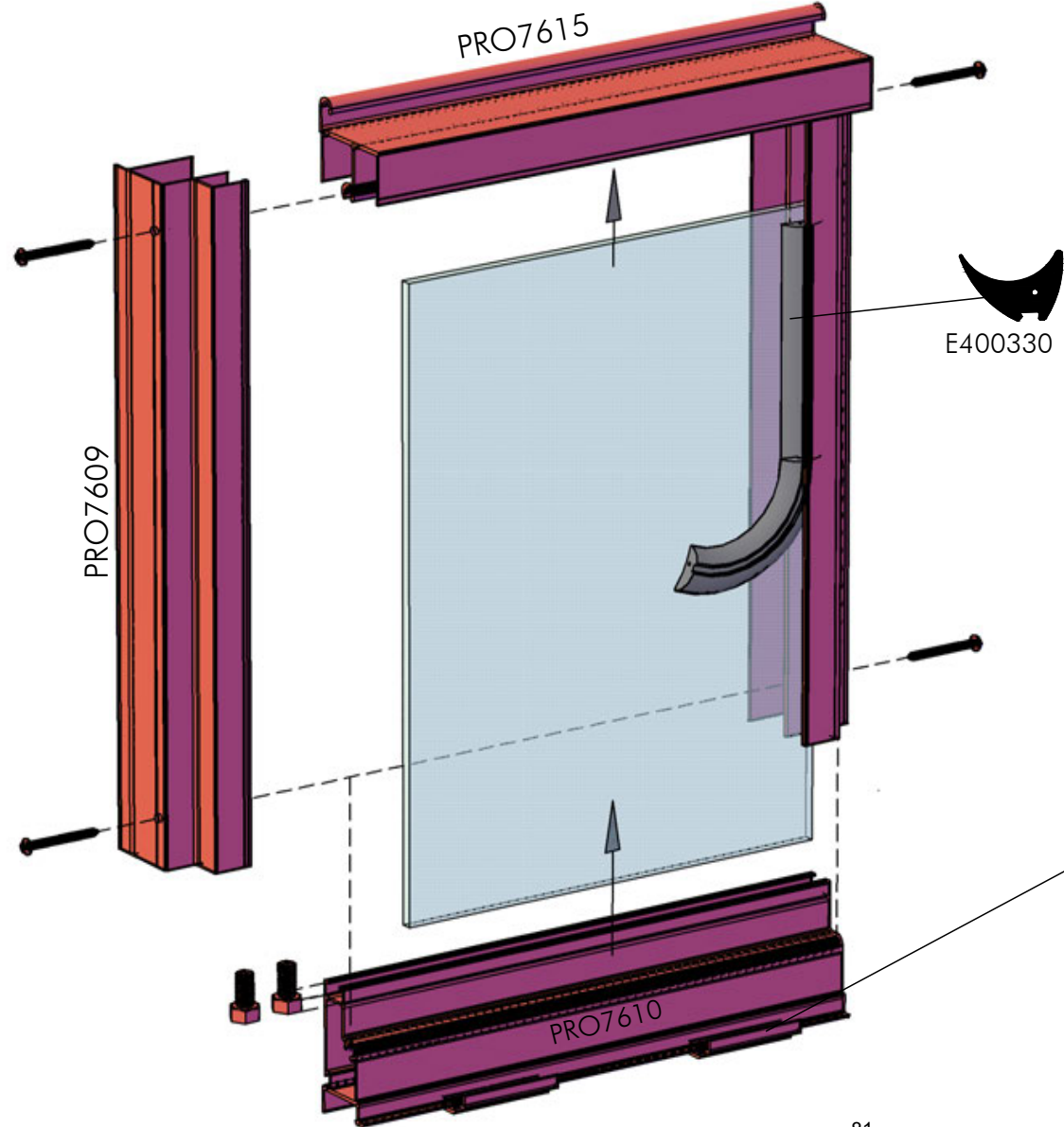

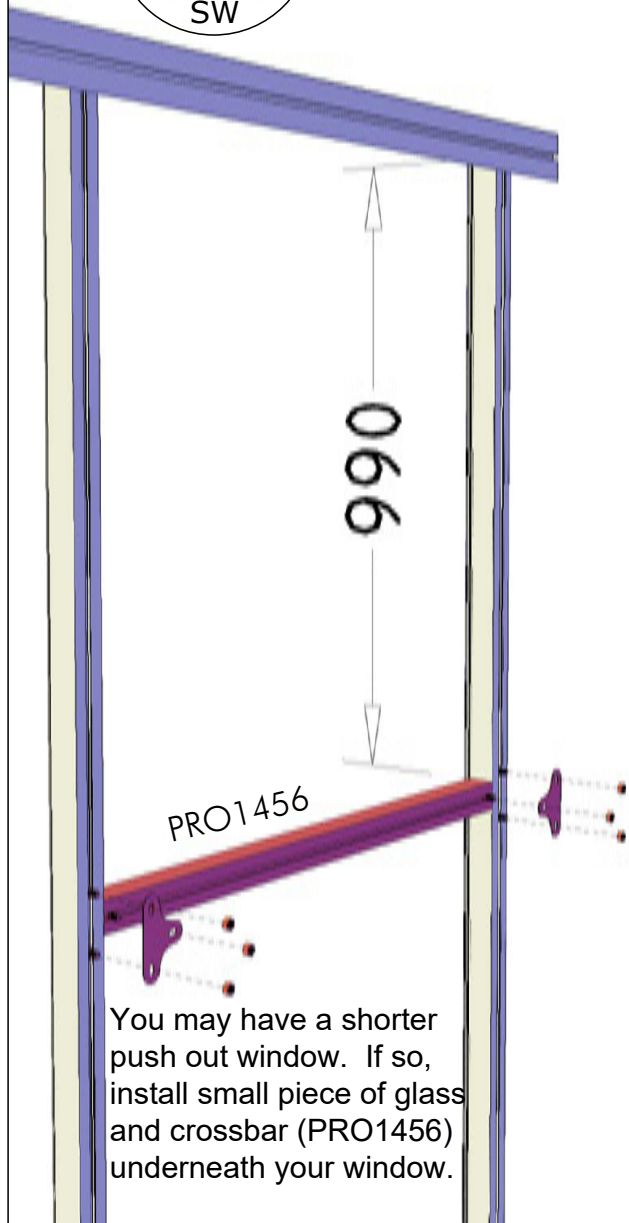
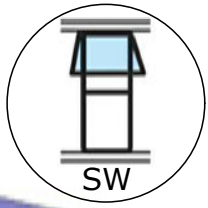

You may have a shorter push out window. If so, install small piece of glass and crossbar (PRO1456) underneath your window.

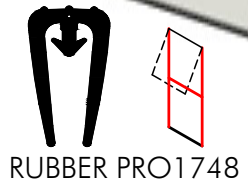
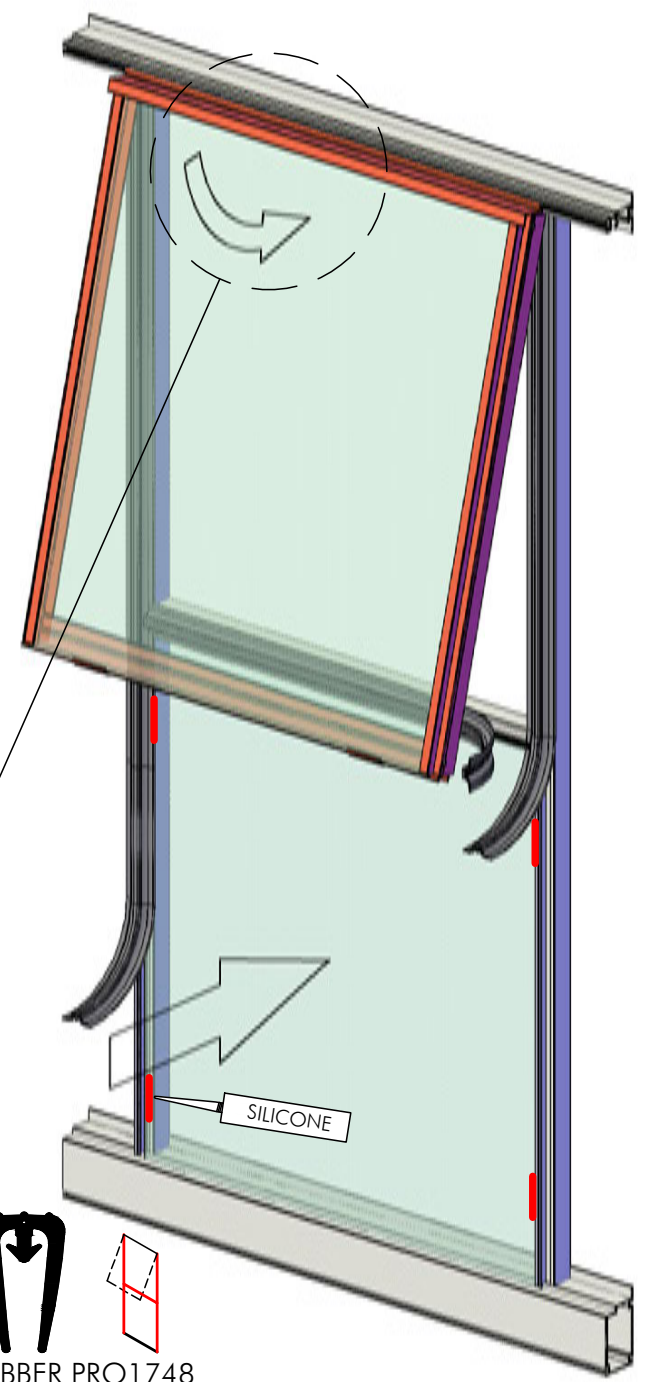
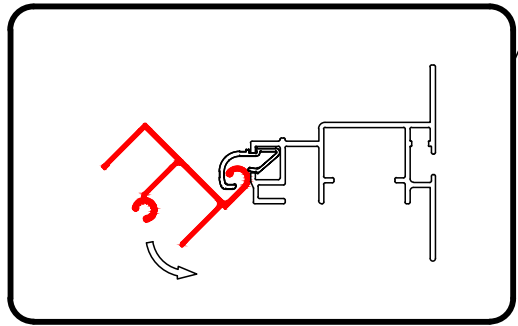
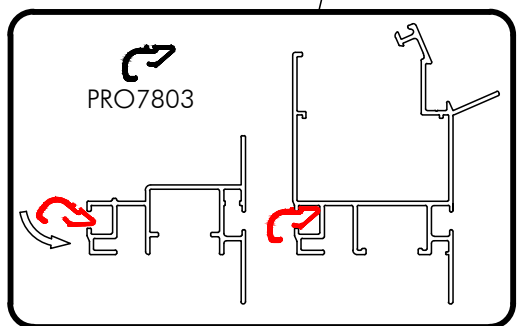
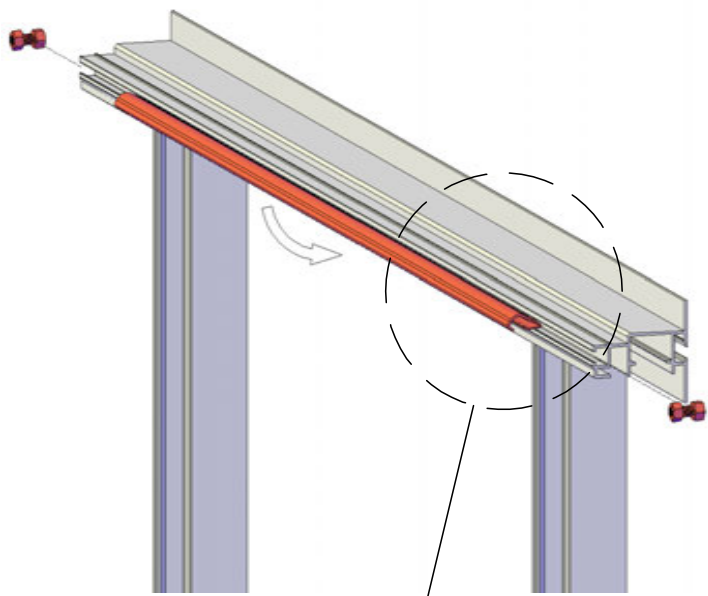

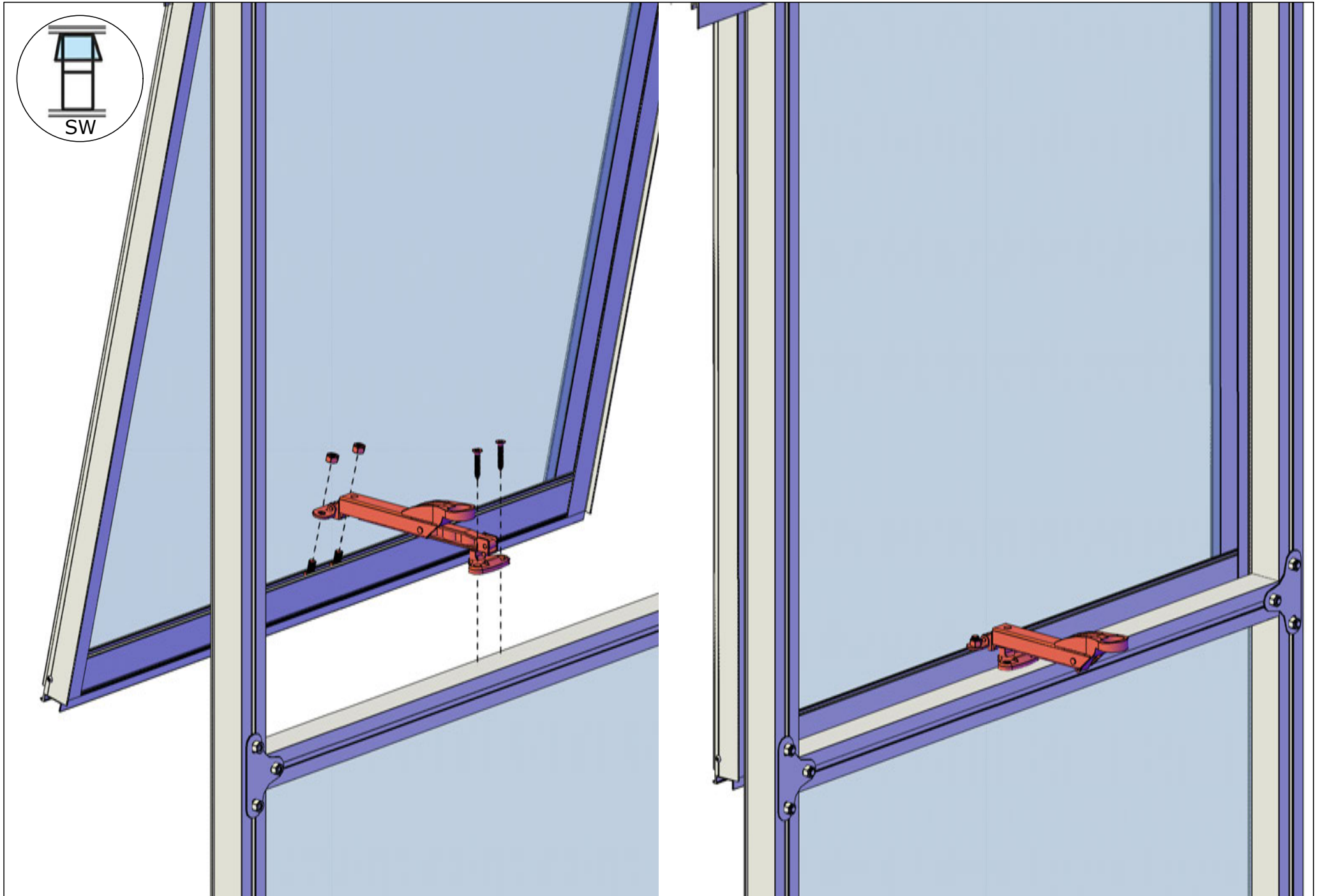

OPTION: Narrow Top Shelf - please check your order to see if this is included

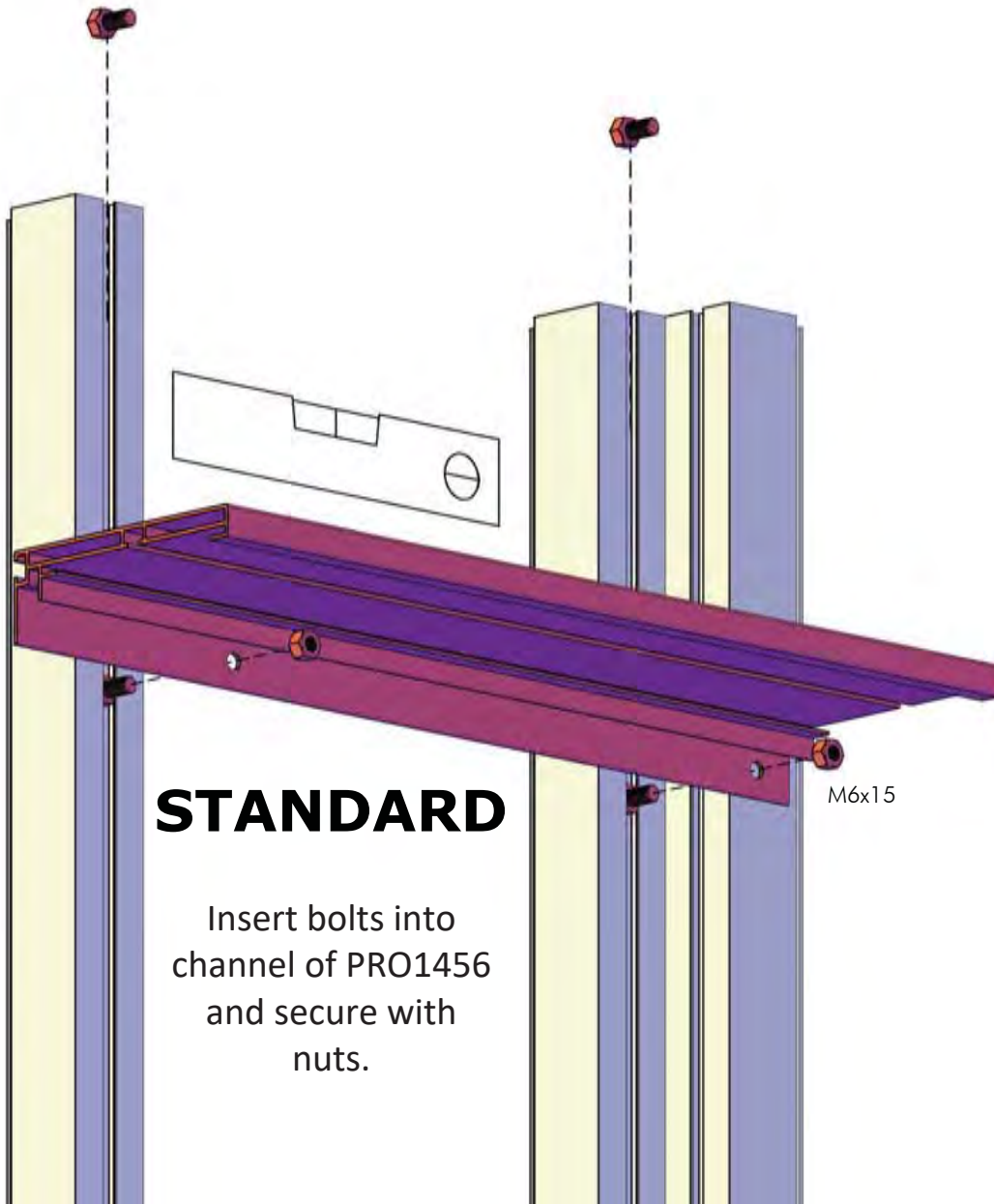

STANDARD

Insert bolts into channel of PRO1456 and secure with nuts.

M6x15

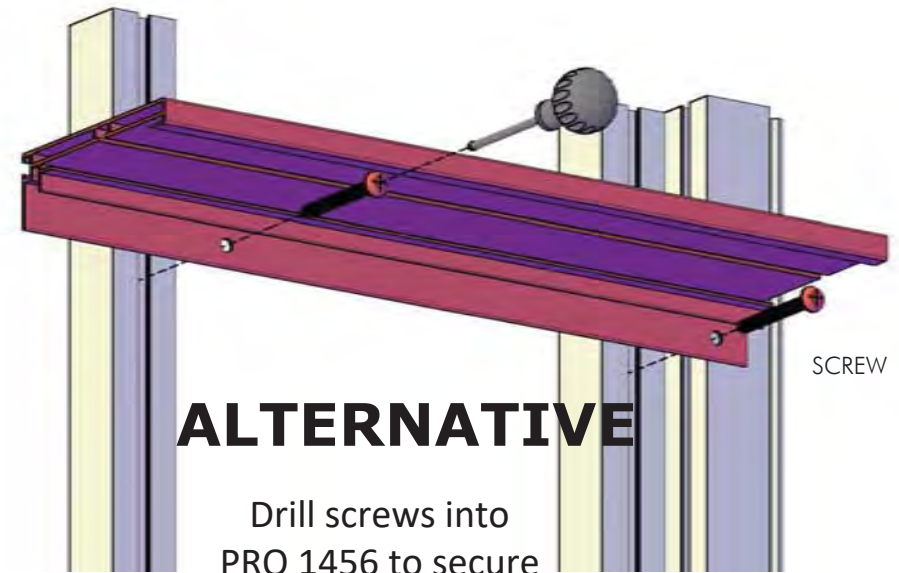
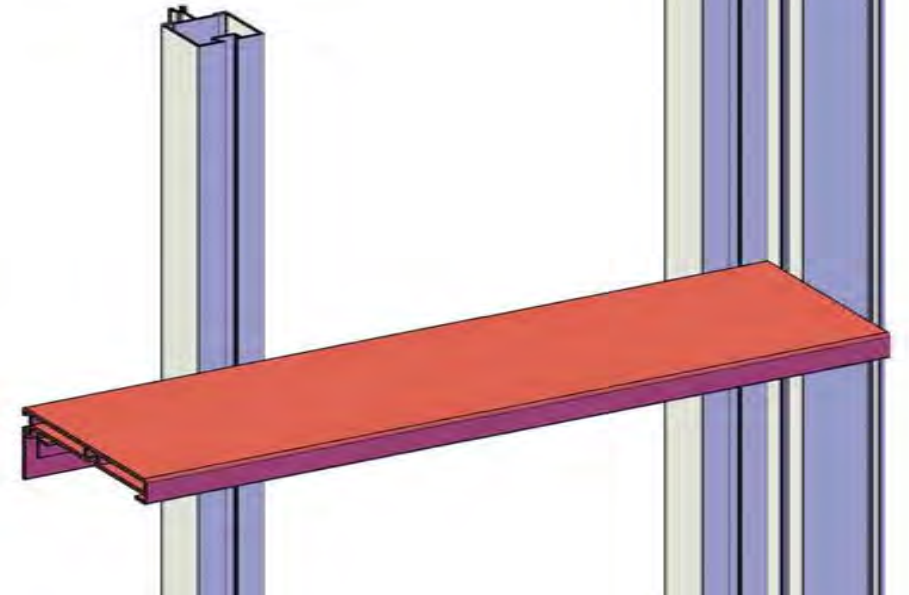

ALTERNATIVE

Drill screws into PRO 1456 to secure

SCREW

SH

OPTION: SEEDBED/SEEDTRAY (ST) Please check your order to see if this was included

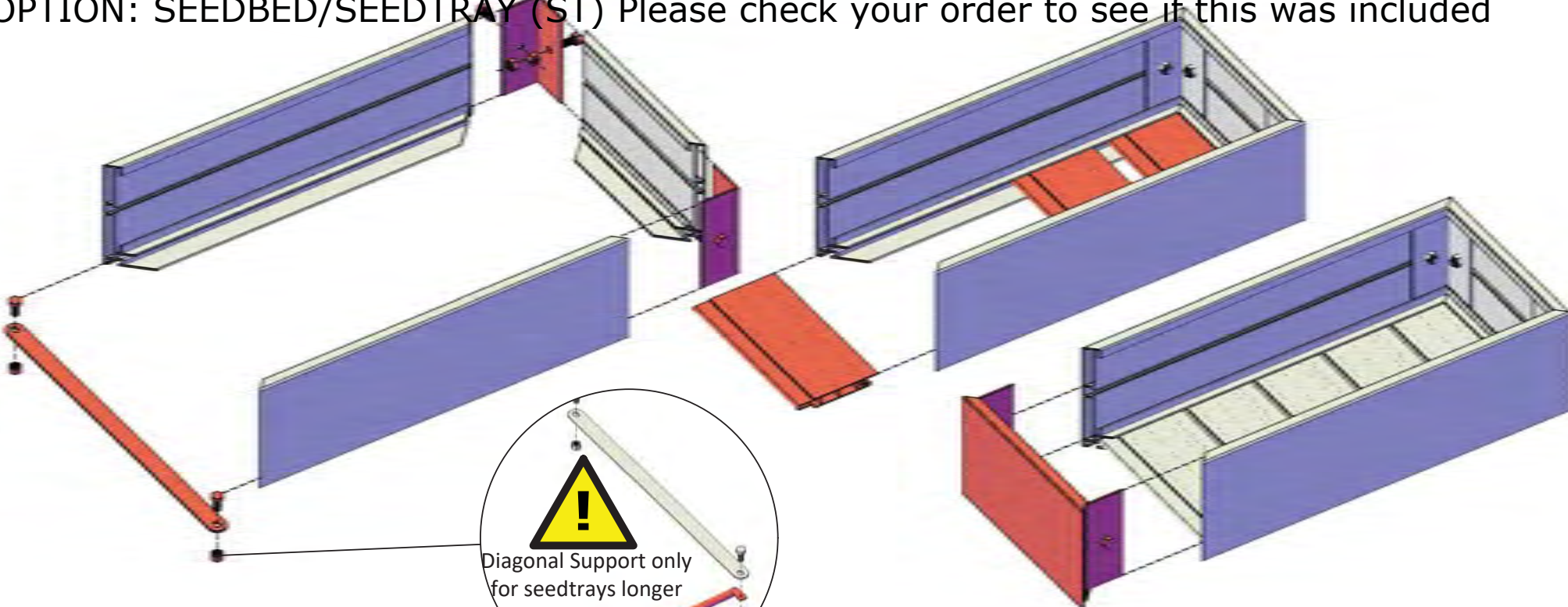

STANDARD

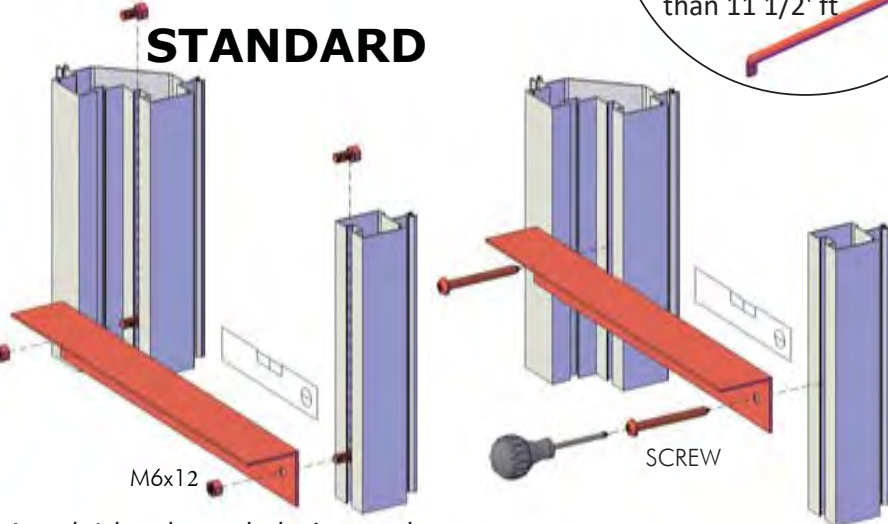

Attach L bracket to bolts inserted into corner post and PRO1456

ALTERNATIVE

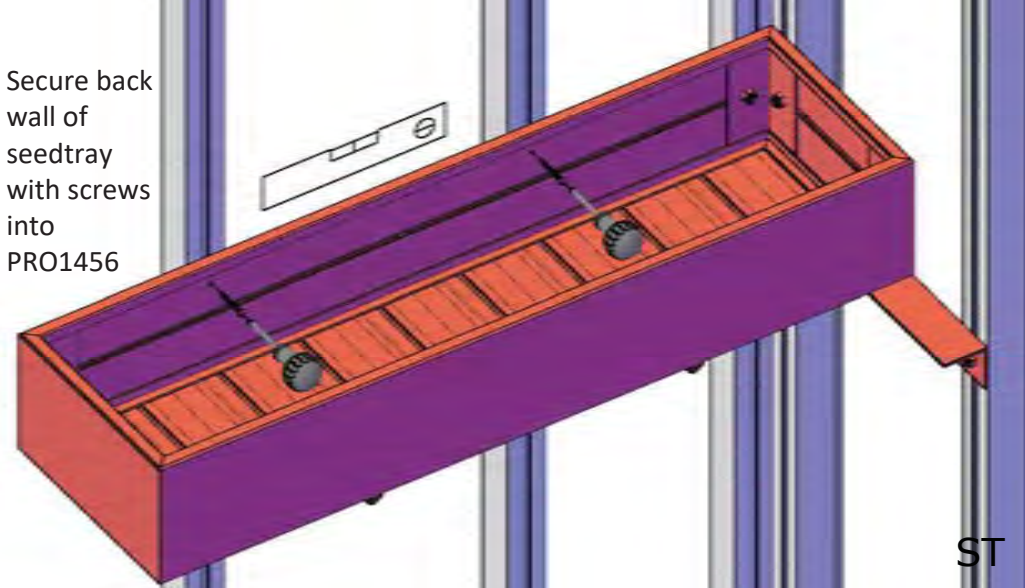

ST

OPTION: 2 Slat Shelf (TAB2)

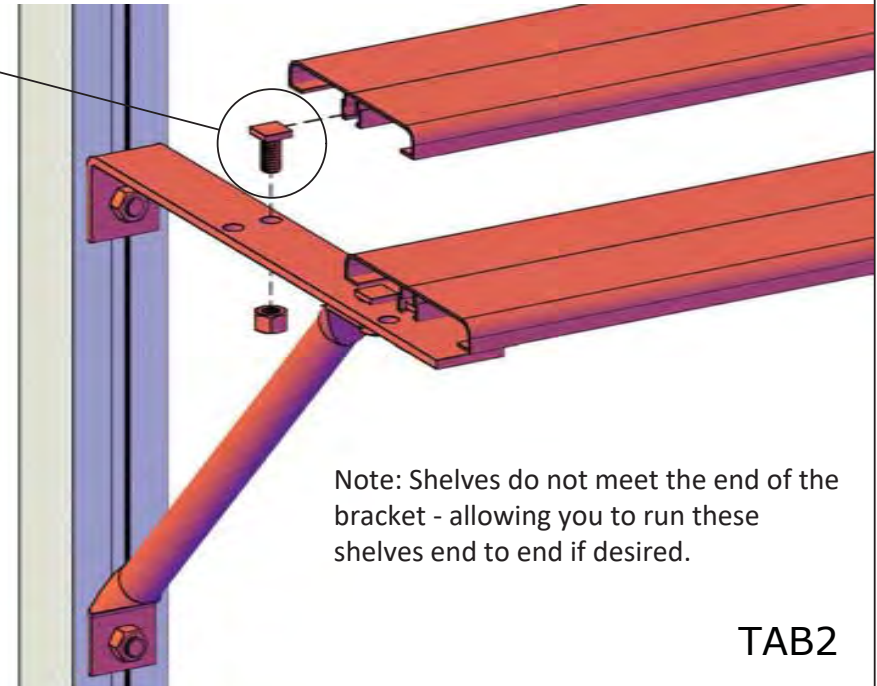
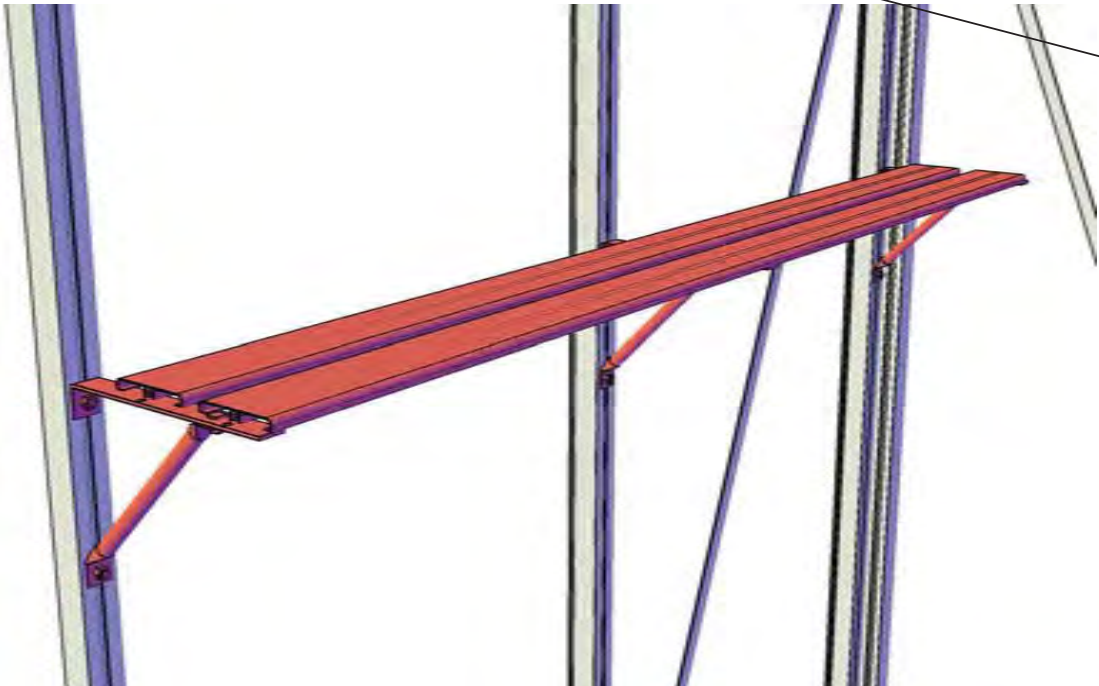
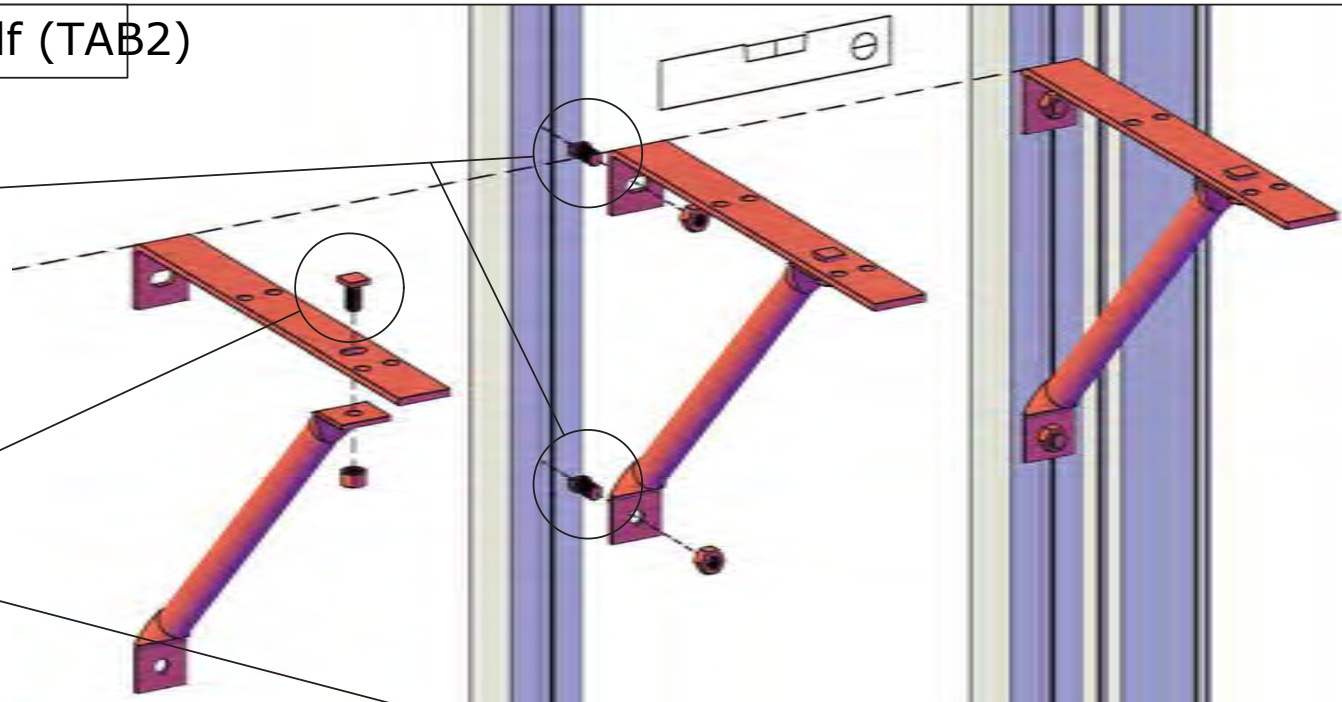
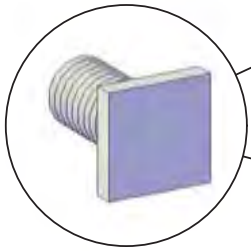
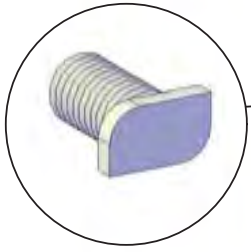

Note: Shelves do not meet the end of the bracket - allowing you to run these shelves end to end if desired.

TAB2

OPTION: 5 Slat Shelf (TAB5)

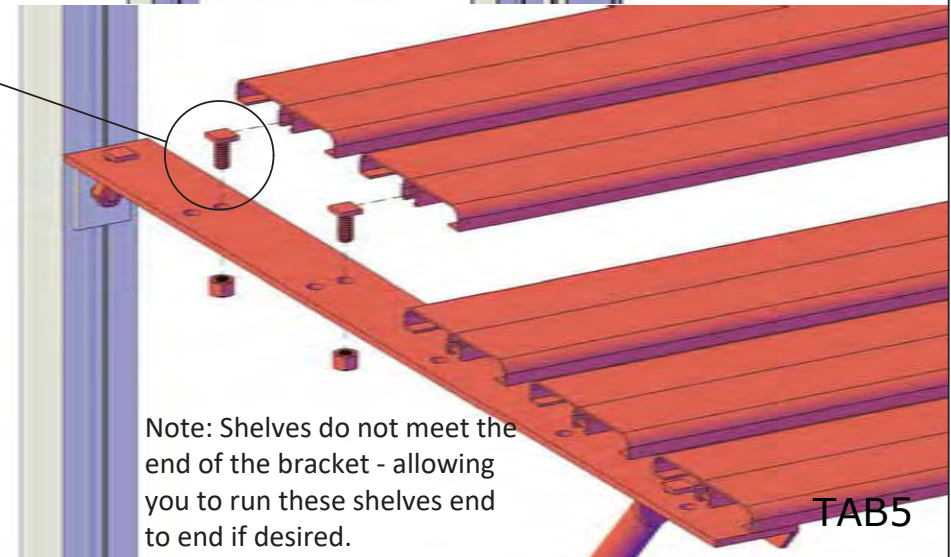
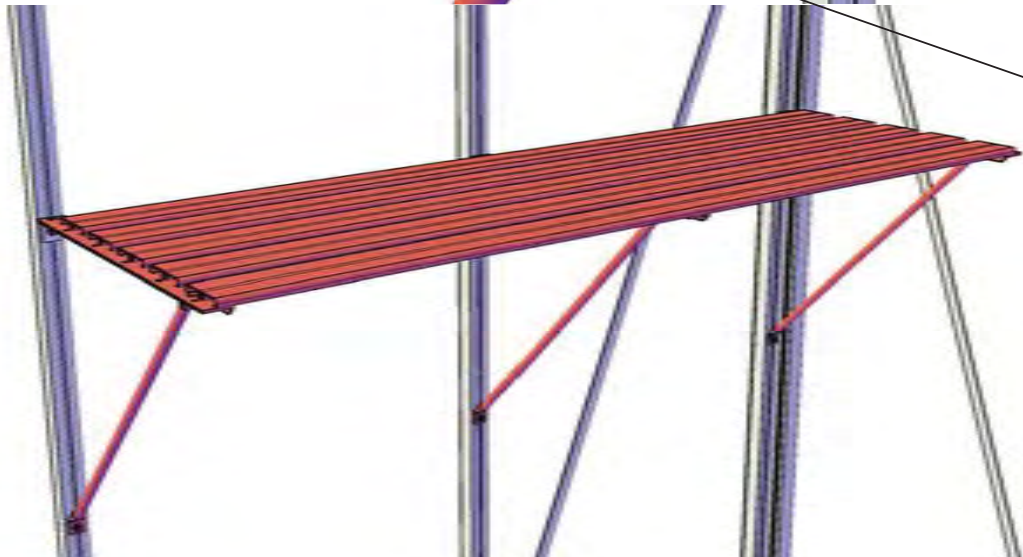
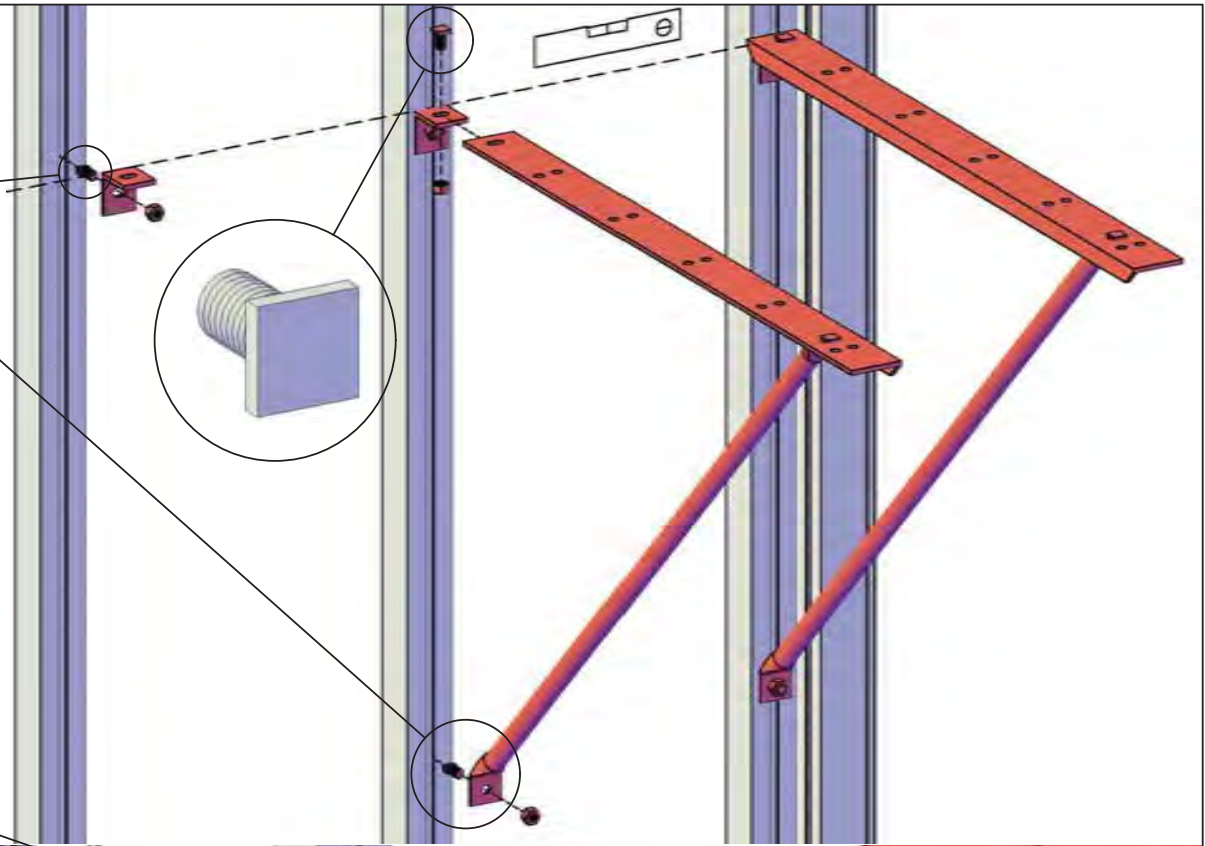
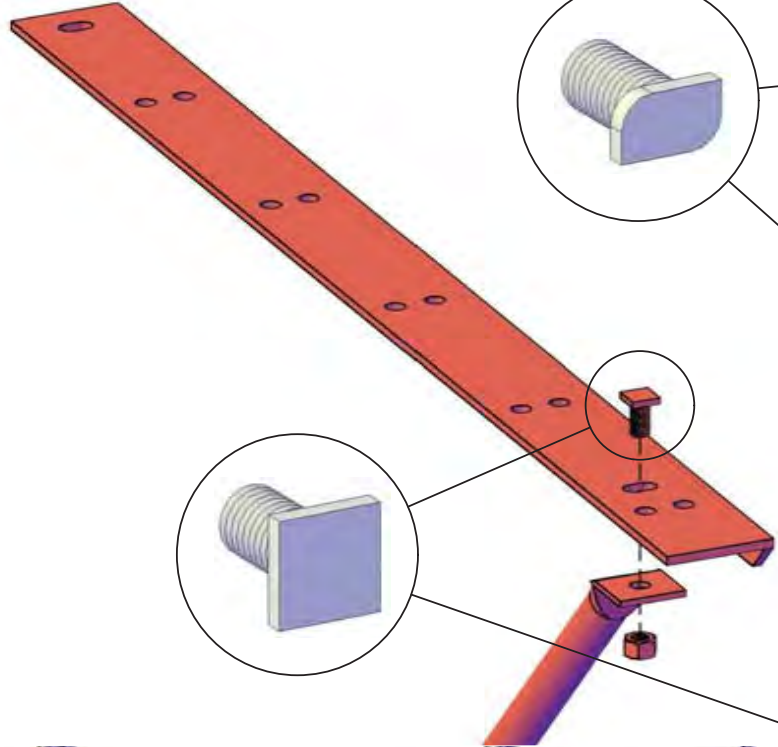

Note: Shelves do not meet the end of the bracket - allowing you to run these shelves end to end if desired.

TAB5

INSTALLING AN EXHAUST FAN IN A VICTORIAN GREENHOUSE

The exhaust fan in a Victorian Greenhouse should be installed up high in one of the gable ends of the greenhouse. If you happen to have polycarbonate walls on your Victorian, you may cut an opening in the polycarbonate to accommodate the fan. If you have glass glazing, we recommend replacing one of your upper angled gable panes with a piece of Lexan. We do offer a precut panel for purchase that is cut with this unusual shape (with a square cut out) that will replace one of the gable panes of glass.

OPTION 1: Attach fan with bolts inserted into channel of PRO1456



Once your panel with the cutout for the fan is in place, mount the fan on the interior of the greenhouse using bolts in the channels of the aluminum extrusions. These bolts will fit through the holes on the exhaust fan. You may need to cut the corner off due to the diagonal support beam being in the way. Once the fan is mounted on two sides to the aluminum extrusions caulk around the area where the box of the shutters meets the glazing.

Option 2: Attach with self-tapping screws

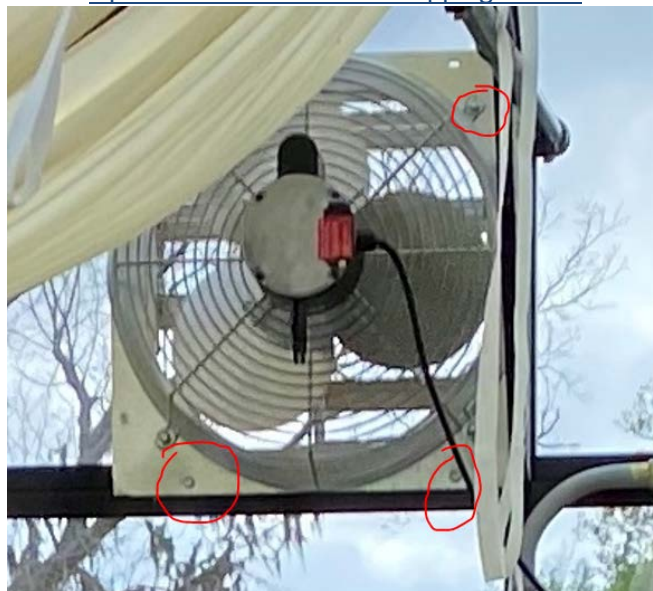

Conversely, you can use self-tapping screws to hold the Exhaust Fan in place. Pre-drill holes in the exhaust fan metal to match up with the Pro1456 Gable piece. You may need to cut the corner off due to the diagonal support beam being in the way. Once the fan is mounted on two sides to the aluminum extrusions caulk around the area where the box of the shutters meets the glazing.



Customer Service or
Assembly Questions?

Give us a call
Toll free: 1-877-760-8500
customerservice@exaco.com
Exaco Trading
www.EXACO.com

*Please watch our animated assembly
video on our Exaco Trading Co
YouTube Channel.
Find the link at www.exaco.com*

Janssens NV Mechelsesteenweg 388, B-2500 Lier Belgium
(T) +32 15 30 67 80 (W) www.janssens-alusystems.be (E) info@janssens-alusystems.be